

# STALOWY DOMEK NARZĘDZIOWY 9m<sup>2</sup>

## METAL BIN STORE 9m<sup>2</sup>

Instrukcja użytkowania  
Instruction manual

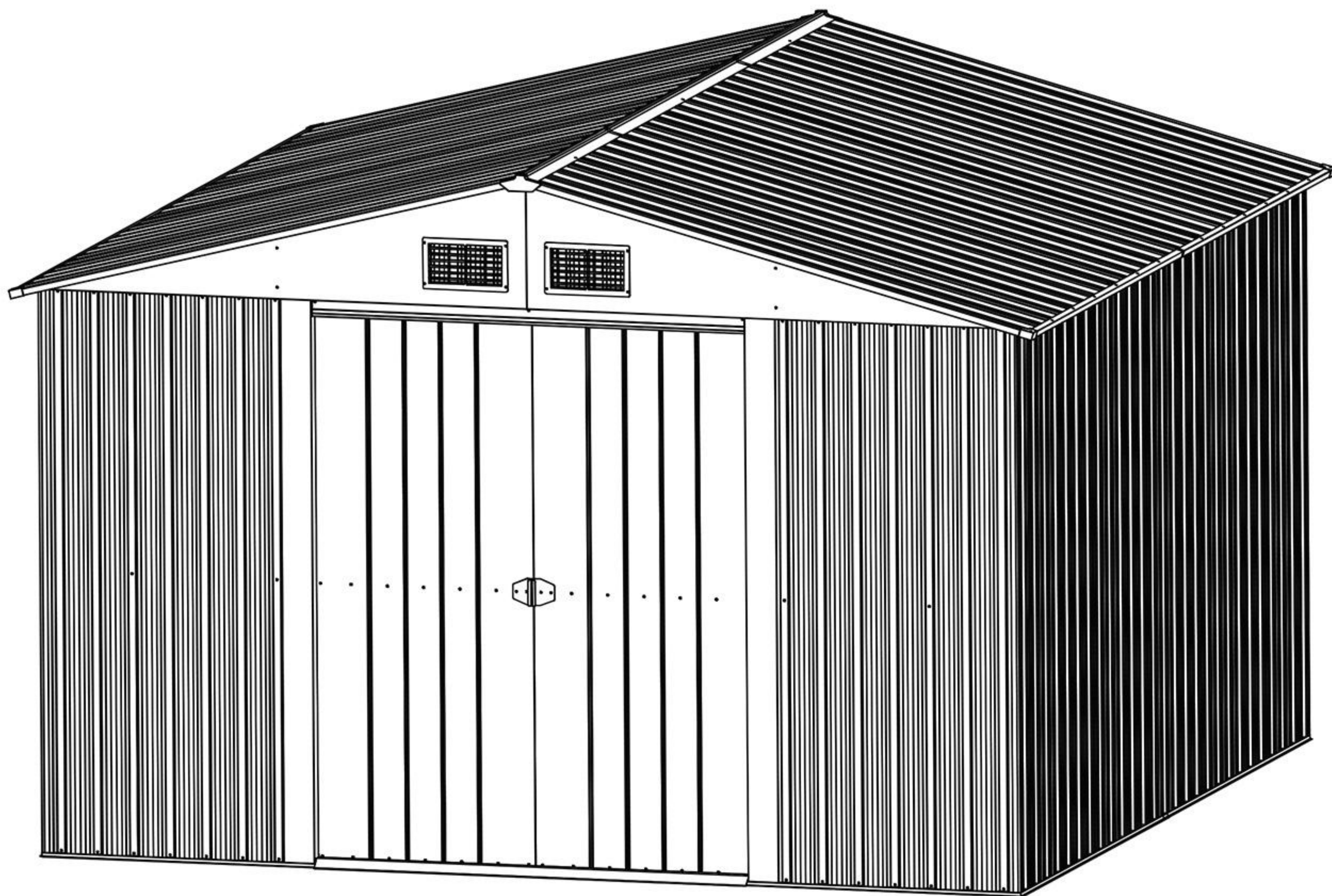

Art nr.: 5904506715671

**PL OSTRZEŻENIA:** Wyłącznie do użytku domowego!  
Do użytku zewnętrznego!

**EN WARNING:** Only for private, non-commercial  
purposes! Outside use only!

**РУ ПРЕДУПРЕЖДЕНИЯ:** Для бытового применения!  
Не для коммерческого использования!  
Использовать на улице.

**CZ POZOR:** Pouze k domácímu použití! Pro venkovní použití!

**DE WARNUNGEN:** Nur für den Hausgebrauch!  
Für den Außeneinsatz!

**IT AVVERTENZE:** Esclusivamente per uso domestico!  
Per uso esterno!

**SL OPOZORILO:** Samo za zasebno uporabo doma!  
Za uporabo na prostem.

**NL WAARSCHUWING:** Alleen voor particulier gebruik, niet voor  
commercieel gebruik! Alleen buiten te gebruiken!

**EE TÄHELEPANU!** Ainult isiklikuks, mitteäriliseks kasutuseks!  
Kasutamiseks üksnes välist-ingimustes!

**LV UZMANĪBU!** Produkts ir paredzēts tikai privātai lietošanai  
mājsaimniecībā, to drīkst izmantot tikai ārtelpās.

**LT DĖMESIO!** Tik privatiems asmenims, nekomerciniams  
tikslams! Tik išoriniam naudojimui!

**HU FIGYELMEZTETÉS:** Kizárólag otthoni használatra!  
Csak kültéri használatra.

**SK POZOR:** Iba na domáce použitie! Pre vonkajšie použitie!



Szybki i łatwy montaż  
Wzmocnione ściany kalenicowe

Quick & Easy Assembly  
Ridge Reinforced Walls



4iQ Group sp. z o.o.  
ul. L. Mierosławskiego 6, 14-200 Ława,  
tel. + 48 89 674 92 57, kontakt@4iQ.com.pl  
www.4iQ.com.pl

## ZANIM ZACZNIESZ

### Instrukcja obsługi

Zapoznaj się z instrukcją obsługi. Informacje w niej zawarte i pomocne wskazówki sprawią, że montaż stanie się łatwy i przyjemny.

Podczas montażu postępuj zgodnie z przedstawioną sekwencją kroków, aby mieć pewność że domek został poprawnie zmontowany.

### Części

Sprawdź kompletność opakowania zgodnie z listą elementów i podziel je według numeracji. W przypadku stwierdzenia jakiegokolwiek braku, nie rozpoczynaj montażu i skontaktuj się ze sprzedawcą.

## NARZĘDZIA, KTÓRE MOGĄ BYĆ WYMAGANE (NIE ZAŁĄCZONO)

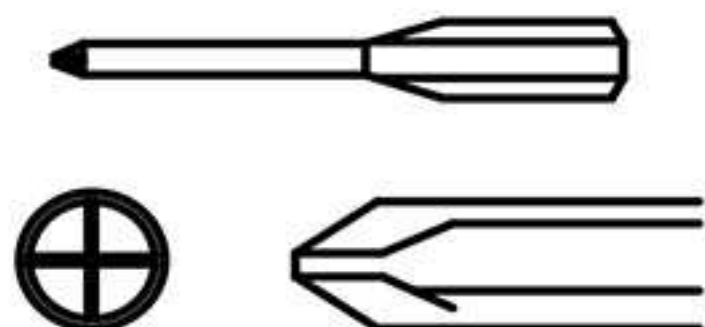
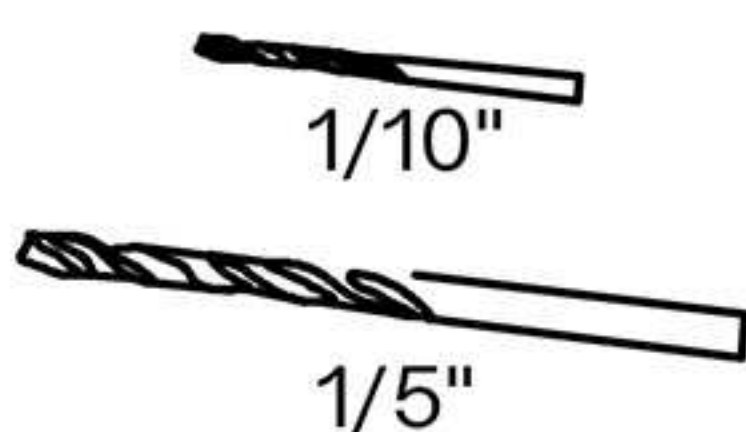
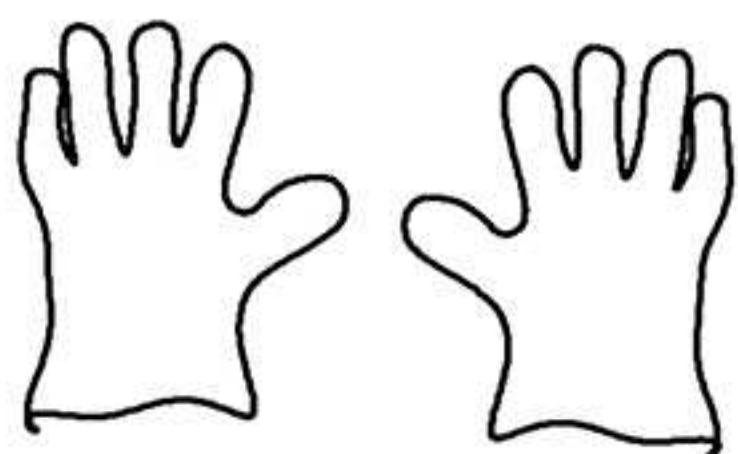

Podczas pracy z blachami stalowymi i obróbką blacharską należy nosić grube rękawice

## BEFORE YOU START

### User manual

Read the user manual. The information contained therein and helpful tips will make installation easy and pleasant. During assembly, follow the sequence of steps presented to ensure that the house is correctly assembled.

### Parts

Check the completeness of the package according to the list of items and divide them by numbering. If any defect is found, do not start assembly and contact the seller.

## TOOLS MAY BE REQUIRED (NOT INCLUDED)

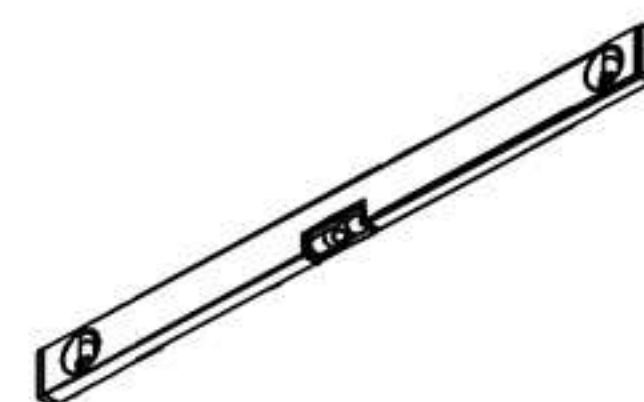
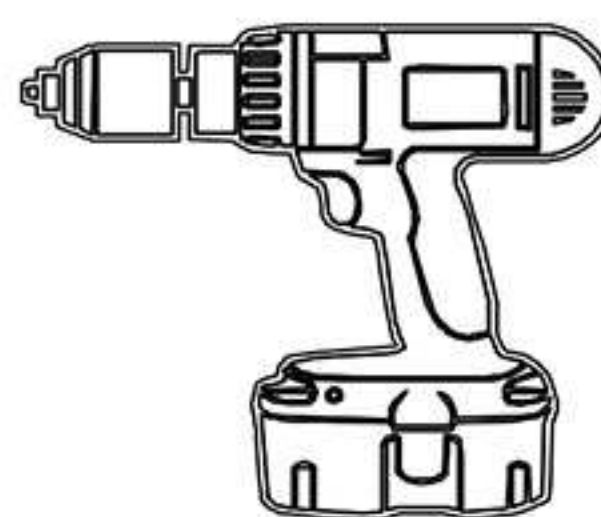
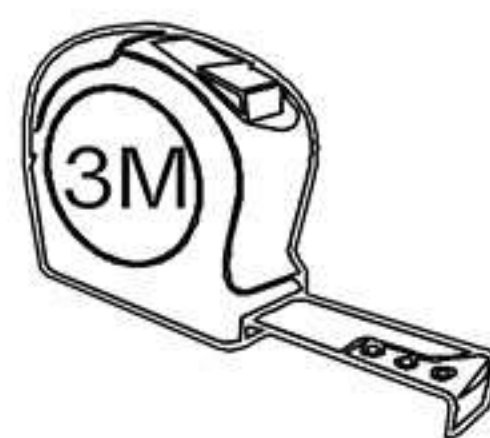

Use heavy duty gloves when handling steel sheets and flashing

## PLANUJ Z WYPRZEDZENIEM

### Obserwuj pogodę:

Upewnij się, że dzień wybrany na instalację jest suchy i spokojny.

**NIE próbuj** montować szopy przy wietrznej pogodzie ze względu na ryzyko uszkodzenia paneli lub obrażeń ciała. Uważaj na mokre lub błotniste podłoże.

### Praca w zespole:

Zawsze, gdy jest to możliwe zaleca się pracę w zespole. Jedna osoba może trzymać lub pozycjonować części czy panele podczas gdy druga montuje okucia czy podaje narzędzia.



## PLAN AHEAD

### Watch the weather:

Please be sure the day you select for installation is dry and calm.

**DO NOT** attempt to assemble your shed in windy weather because of risk of damage to panels, or personal injury. Be careful of wet or muddy ground.

### Teamwork:

Whenever possible, two or more people should work together to assemble the building. One person can position parts or panels while the other is able to handle the fasteners and the tools.

## PLANUJ Z WYPRZEDZENIEM

### Wybór miejsca

- W miarę możliwości unikaj instalacji pod drzewami, ponieważ spadające liście będą wymagały regularnego ich usuwania, a potłamsane gałęzie będą stanowiły potencjalne ryzyko uszkodzenia.
- Małe drzewa, krzewy lub płoty w pobliżu mogą być pomocne, działając jako ochrona przed wiatrem.

### Przygotowanie miejsca

1. Miejsce należy przygotować w taki sposób, aby podstawa szopy była równa i sprawdzona za pomocą poziomicy.
2. Podstawa może być wykonana z impregnowanego drewna lub betonu, aby zatrzymać wilgoć. Szopa nie jest przeznaczona do bezpośredniego posadowienia na trawniku ze względu na wilgoć, a także na ryzyko błotnistej ziemi w dni deszczowe.
3. W przypadku wykorzystania betonowej podstawy, należy zapewnić jej pochyłość, aby zapobiec gromadzeniu wody. Przed postawieniem szopy na podstawie należy poczekać aż beton lub cement wyschną.
4. Podstawę można również zbudować z cegieł, bloków lub zamontować na betonowej podkładce. Cegły lub bloki należy zacementować, tworząc wypoziomowane betonowe fundamenty, a ramę szopy nawiercić i przykręcić do podstawy.

## PLAN AHEAD

### Site Selection:

- Avoid overhanging trees as much as possible as leaves will make regular cleaning necessary and broken branches are a potential hazard.
- Small trees, bushes or fences nearby can be helpful, acting as a wind break.

### Site Preparation

1. The site must be prepared so that the base of the shed is level all round and checking with a spirit level is required.
2. The base can be constructed by treated timber or concrete, in order to stop the moisture getting into the shed. **The shed is not designed to be built onto lawn directly.** Also the ground will get muddy during rainy days.
3. If a concrete pad is made, it is important that this slopes towards the edges to prevent water ingress. Time must be allowed for any concrete or cement to dry before building the shed on top.
4. Bases can also be constructed from bricks, blocks, or mounted on a concrete pad. The bricks or blocks should be cemented onto firm and level concrete footings and the greenhouse frame drilled and screwed to the base.

### Ostre krawędzie

Zwróć uwagę na ostre krawędzie. Podczas montażu należy nosić rękawice robocze, długie rękawy i okulary.

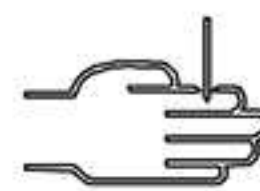
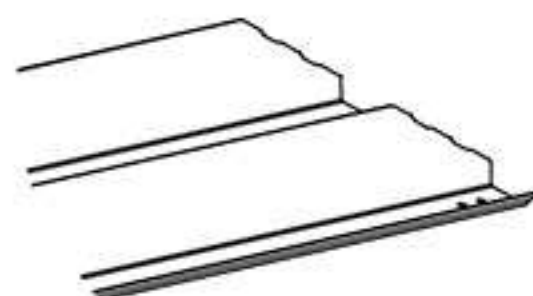

### Sharp Edges

Pay attention to the sharp edges. Please wear work gloves, long sleeves and eye glasses, when assembling or performing.











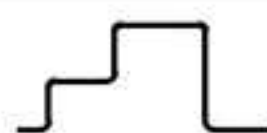
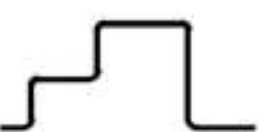
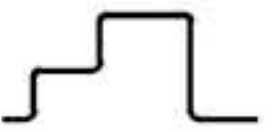
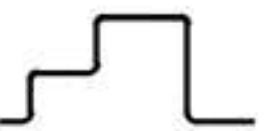

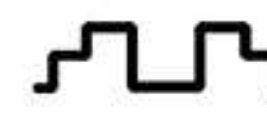

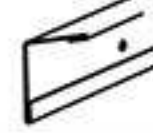
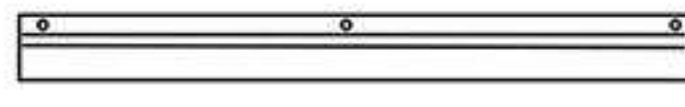

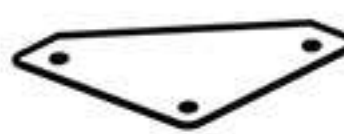
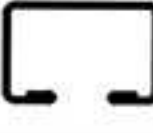
## WAŻNE UWAGI!

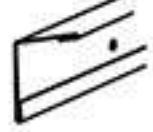

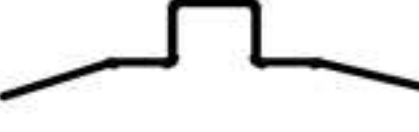

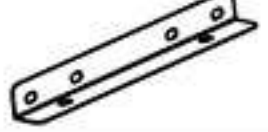

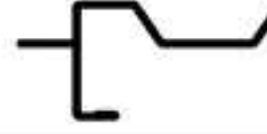





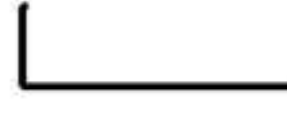

1. Znajdź kogoś, kto Ci pomoże: znacznie łatwiej jest, gdy ktoś trzyma części i podaje narzędzia itp.. Ponadto niektóre kroki wymagają dwóch osób do wspólnego podnoszenia konstrukcji. Montaż nie jest zbyt trudny więc będzie odpowiedni dla większości pełnosprawnych osób.
2. **Nie spiesz się:** pośpiech często powoduje błędy i powtarzanie błędnych kroków. Jeśli nigdy wcześniej nie budowałeś szopy, dokładne jej zbudowanie może zająć większą ilość czasu.
3. Miej pod ręką odpowiednie narzędzia.
4. Zalecana jest odzież ochronna.
5. Najlepiej rozłożyć części i przed rozpoczęciem sprawdzić, czy są kompletne. Jeżeli istnieje ryzyko zarysowania części, należy je położyć na ściereczkach lub prześcieradłach z tworzywa sztucznego.
6. Ostrożnie dokręć wszystkie nakrętki, uważając, aby żadnej nie przeoczyć. Sprawdź, za pomocą poziomicy czy konstrukcja jest ustawiona pionowo i czy jest foremna.

## IMPORTANT NOTES!







1. Find someone to help you: it is much easier with someone to hold parts, pass tools ect. Also some steps require two people to lift structures together. This is not very heavy work so would suit most able-bodied people.
2. **Allow plenty of time:** rushing often causes errors and the re-doing of incorrect assemblies. If you have never built a shed before, it can take most of a day to carefully complete the construction.
3. Have the right tools to hand.
4. Safety clothing as recommended in the 'Tools' section.
5. Ideally lay out the parts and check that all are present before commencing construction. Lay on cloths or plastic sheets if there is any risk of scratching the parts
6. Tighten all nuts carefully, being sure not to miss any. Check the frame is square and using a spirit level to check that it is upright.









# Profile/Profile Bar

NO./NR	PART/ELEMENT	QTY./ ILOŚĆ
1		1
2		1
3		2
4		1
5		1
7		1
8		1
9		1
10		4
11		1
12		4
13		1
14		4
15		4
17		2
18A		2
18B		2
19		2
19A		1
20		4
21		2
22A		1
22B		1

NO./NR	PART/ELEMENT	QTY./ ILOŚĆ
23		4
24		4
25		2
27A		2
27B		2
28		4
30		2
31		2
32A		2
32B		2
33A		1
33B		1
34L		1
34R		1

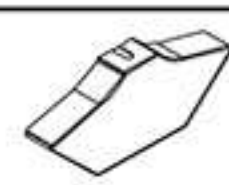

# Profile/Profile Bar

NO./NR	PART/ELEMENT	QTY./ ILOŚĆ
P1		4
P2		19
P3		2
P4		2
P5		2
P6		10

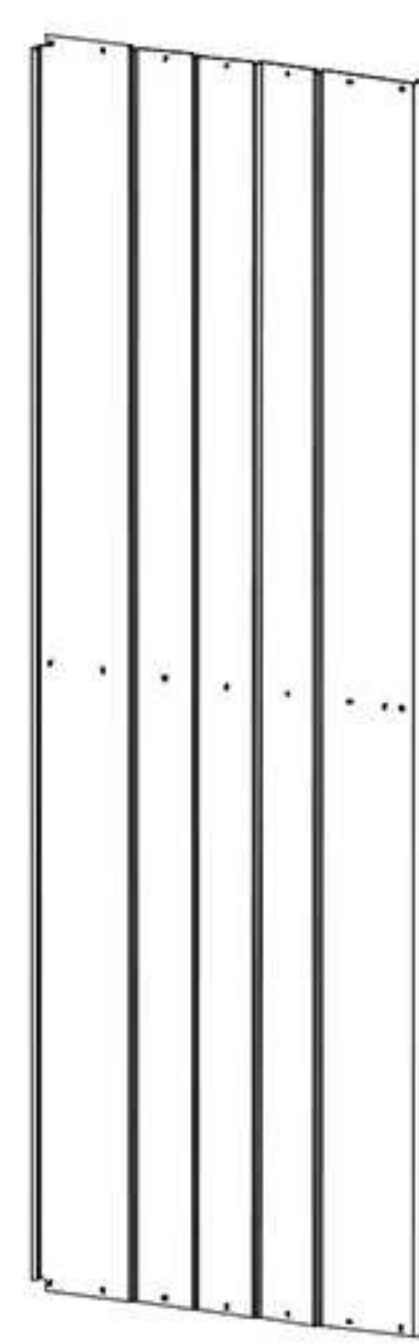
NO./NR	PART/ELEMENT	QTY./ ILOŚĆ
F1		442
F2		183
S3		442
G2		4
GB		2
GC		4
GD		4
GE		2
GF		4

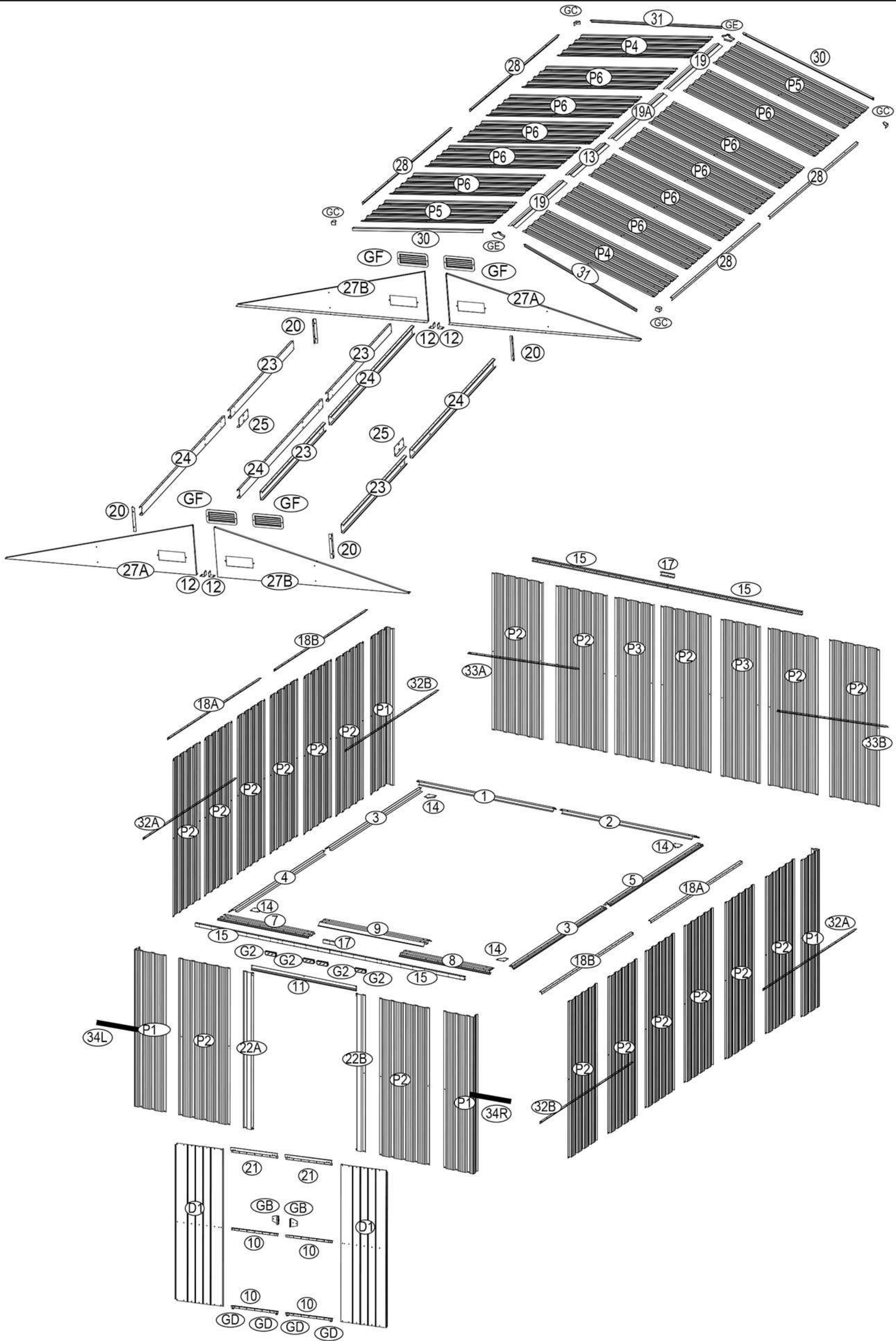
NO./NR	PART/ELEMENT	QTY./ ILOŚĆ
D1		2

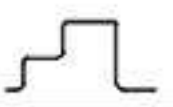
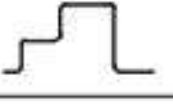

NO./NR.	PART/ELEMENT	QTY./ ILOŚĆ
1		1
2		1
F1		3

Montaż podstawy  
Base Assembly

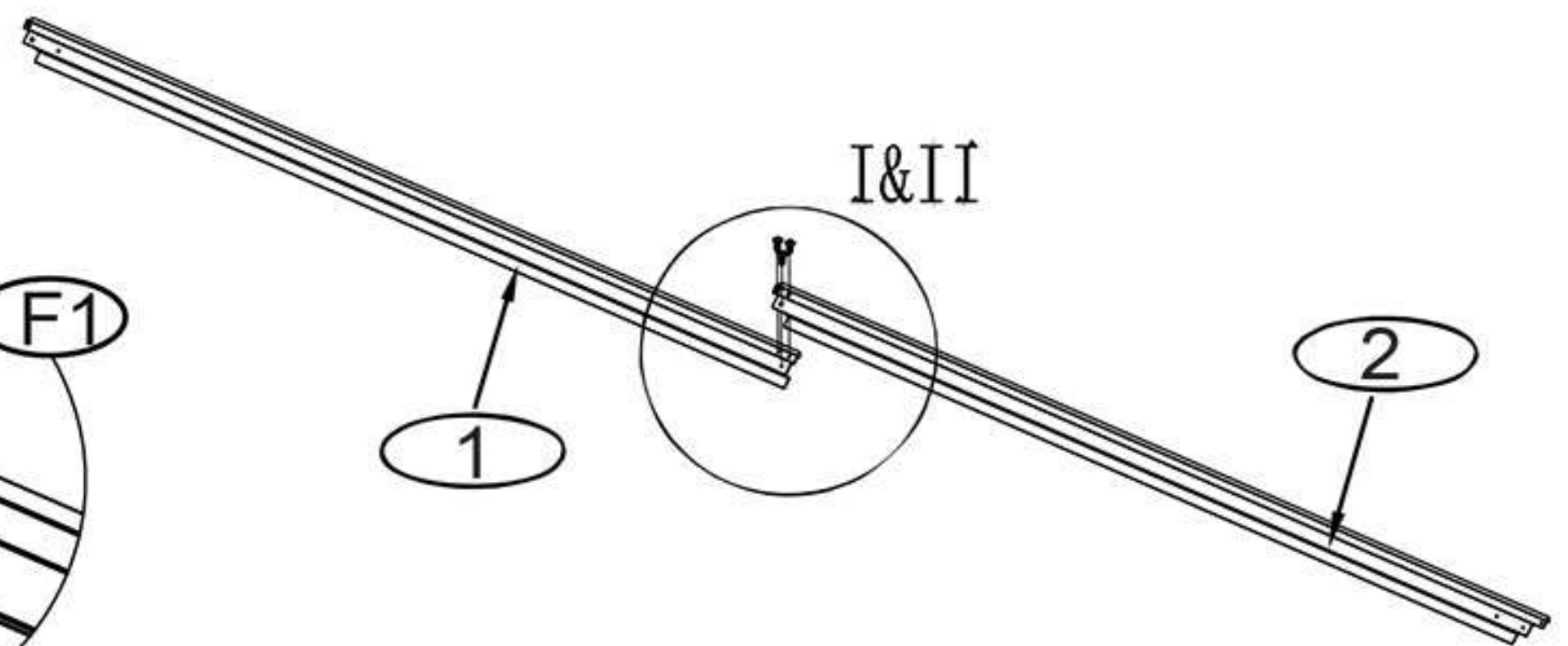
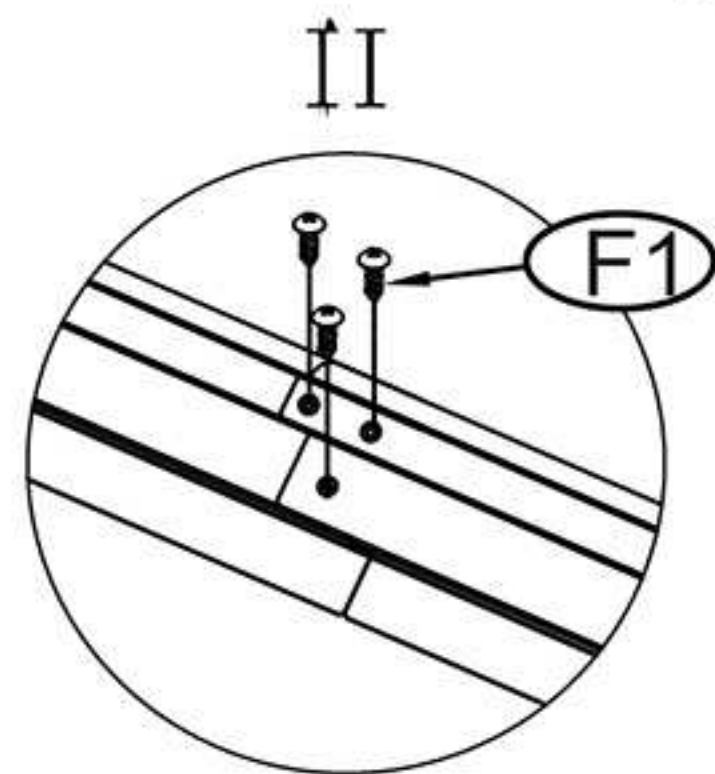
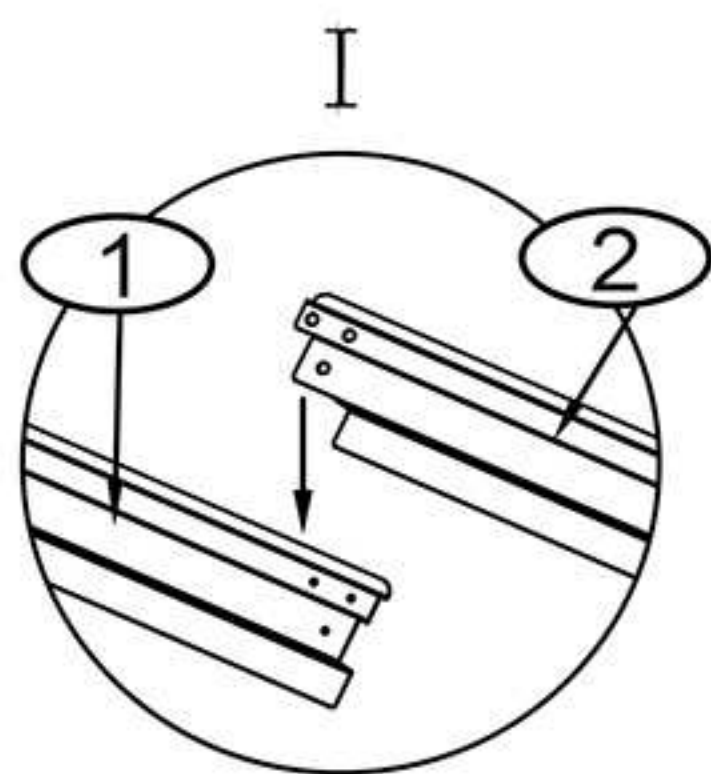

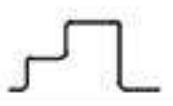
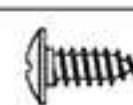
NO./NR.	PART/ELEMENT	QTY./ ILOŚĆ
3		1
4		1
F1		3

Montaż podstawy  
Base Assembly

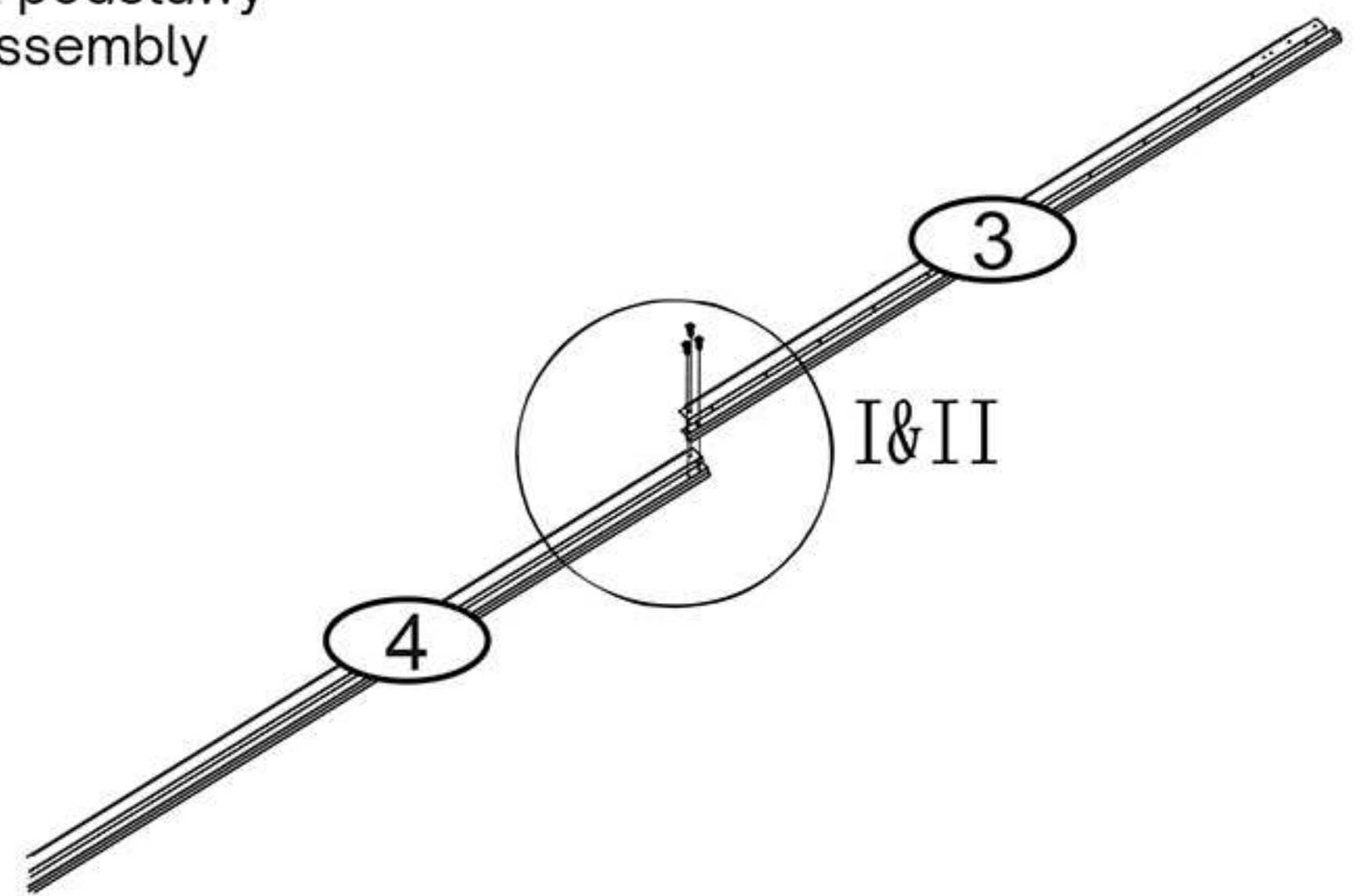
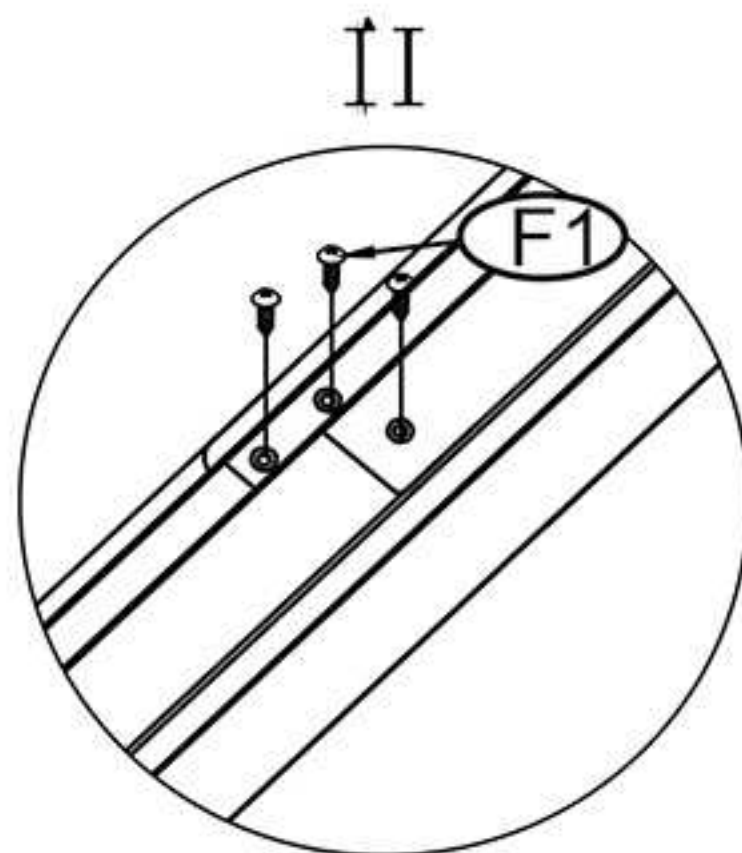
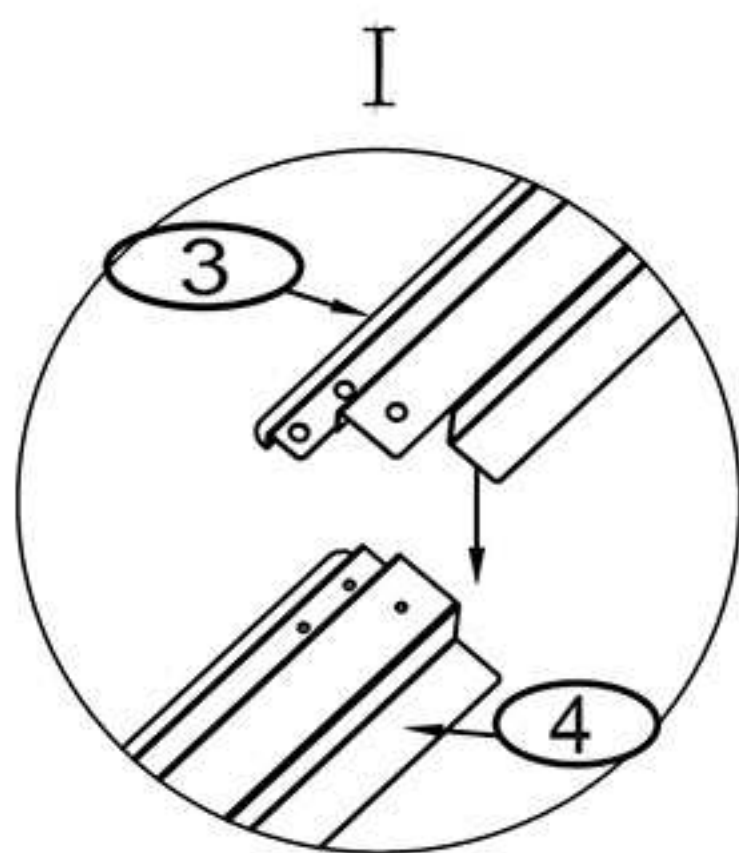

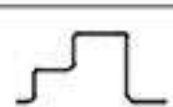
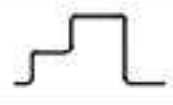
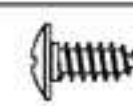
NO./NR.	PART/ELEMENT	QTY./ ILOŚĆ
3		1
5		1
F1		3

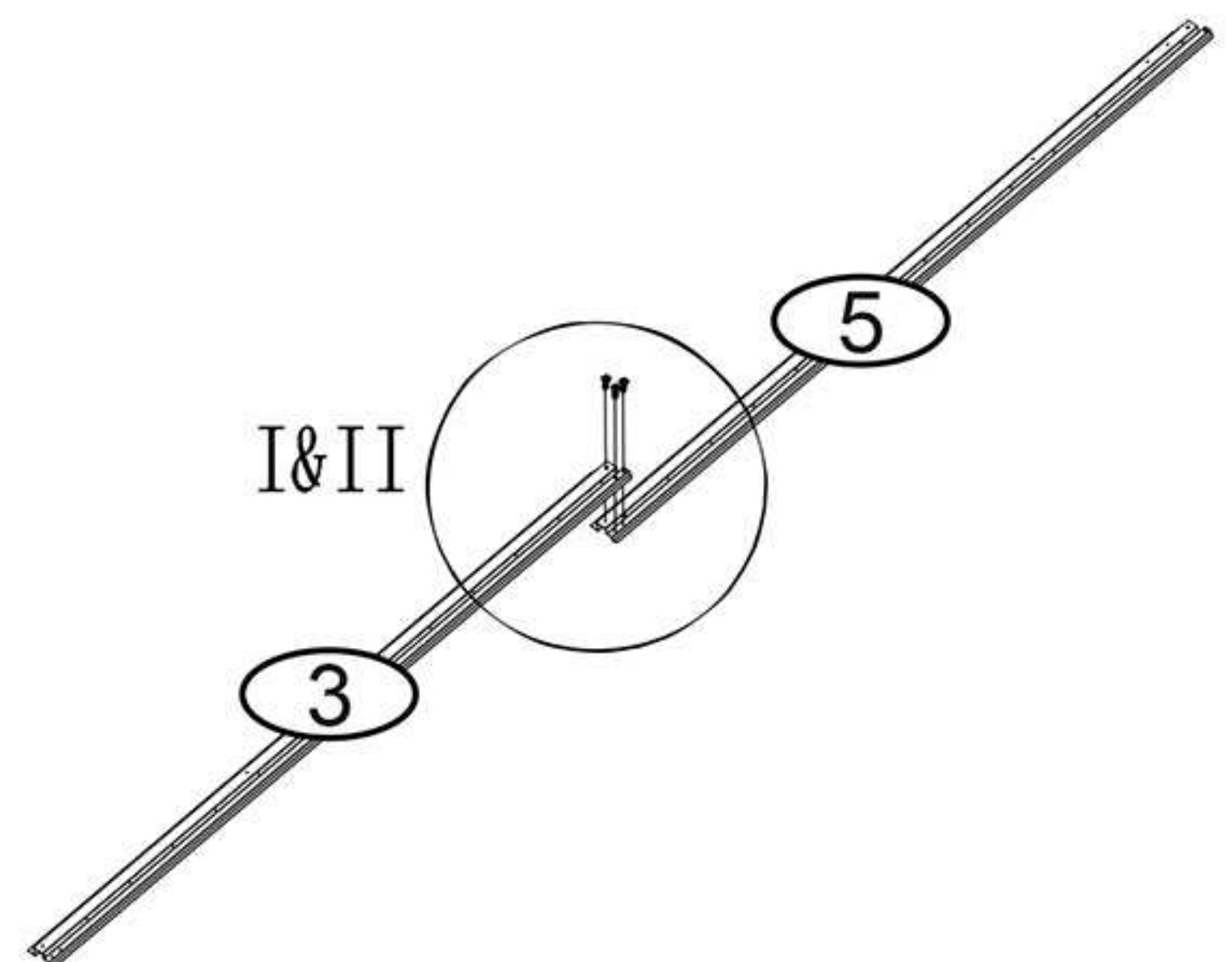
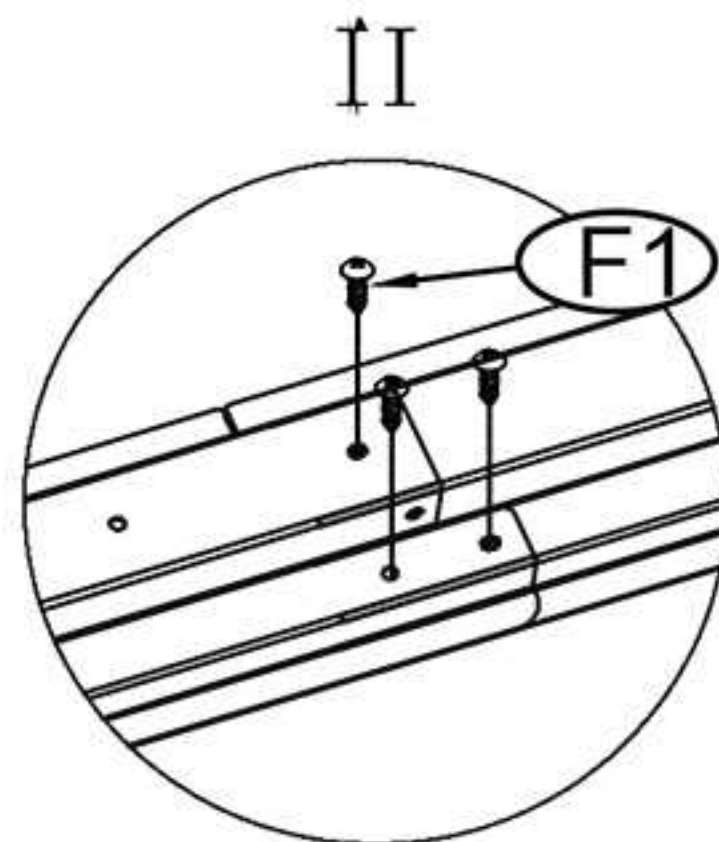
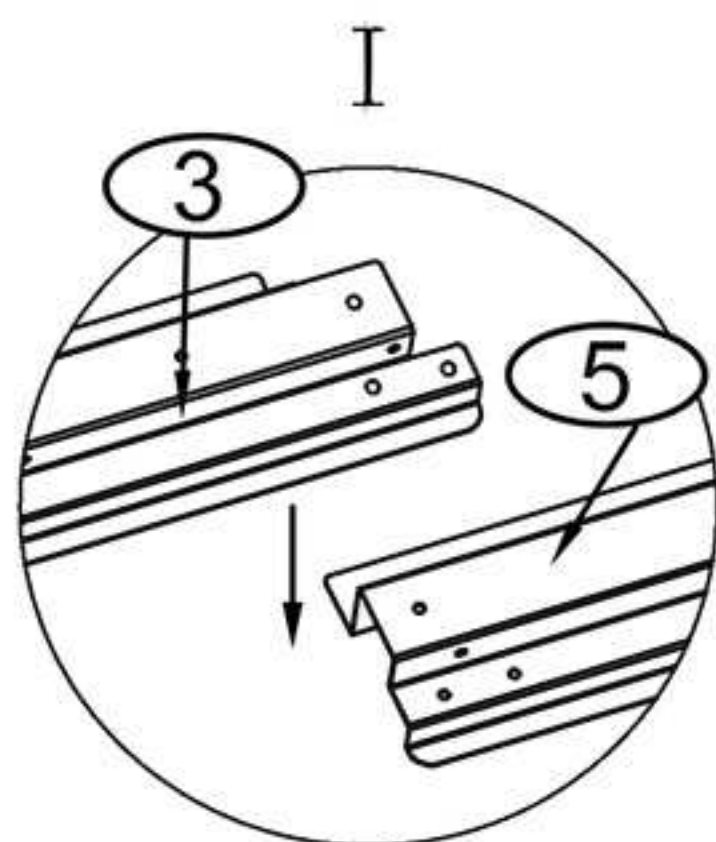

Montaż podstawy  
Base Assembly

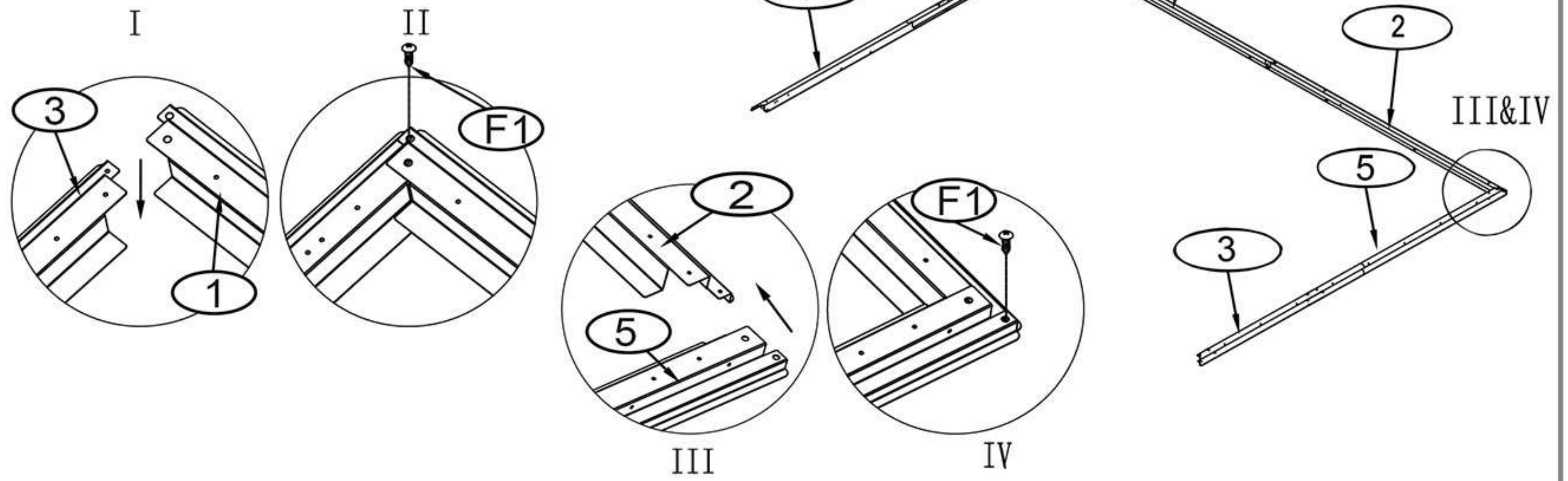

NO./NR	PART/ELEMENT	QTY./ ILOŚĆ
F1		2

Montaż podstawy  
Base Assembly



NO./NR	PART/ELEMENT	QTY./ ILOŚĆ
7		1
8		1
F1		4

Montaż podstawy  
Base Assembly

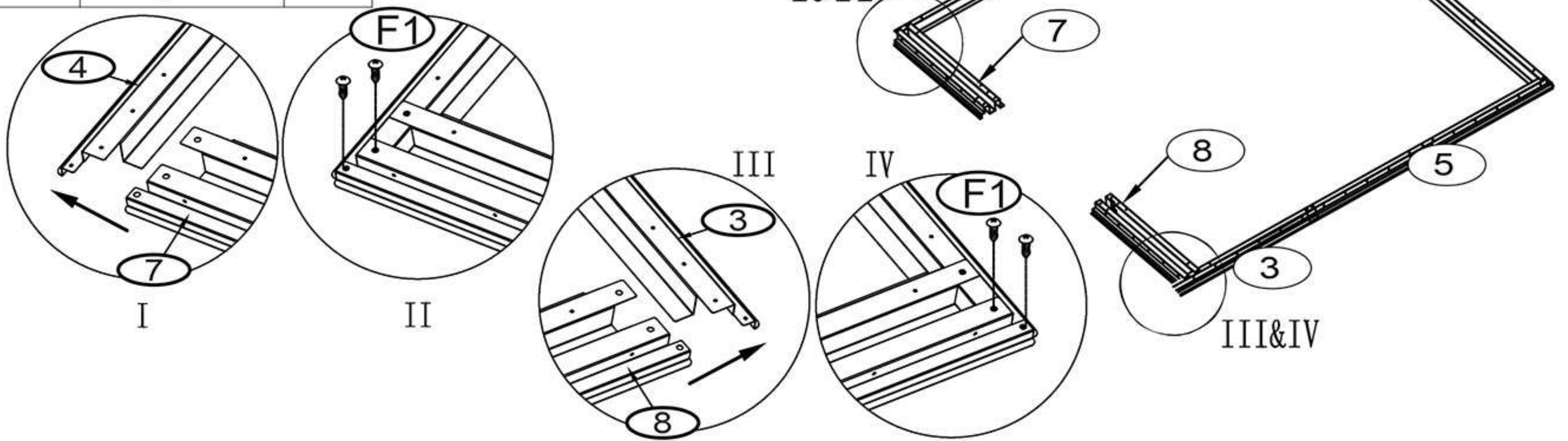

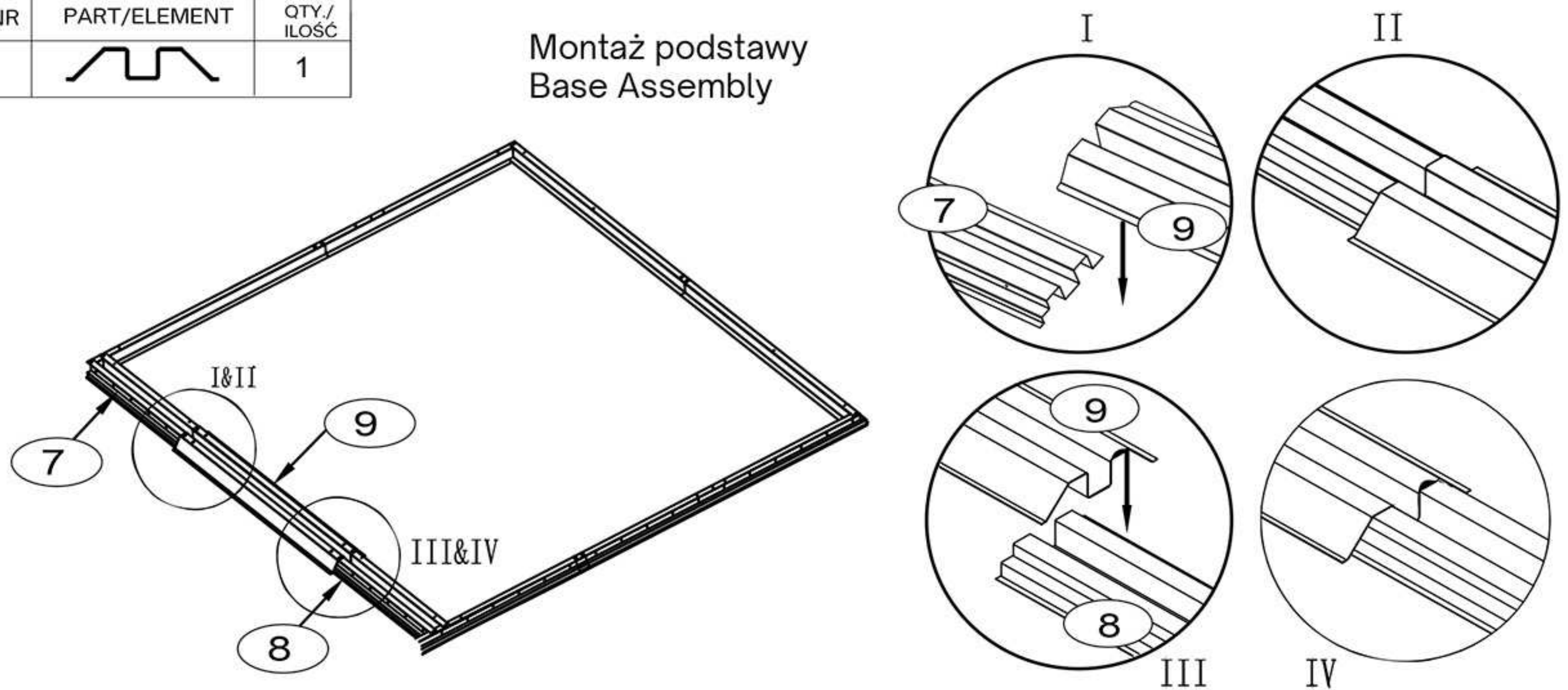

NO./NR	PART/ELEMENT	QTY./ ILOŚĆ
9		1

Montaż podstawy  
Base Assembly





NO./NR	PART/ELEMENT	QTY./ ILOŚĆ
14		4
F1		12

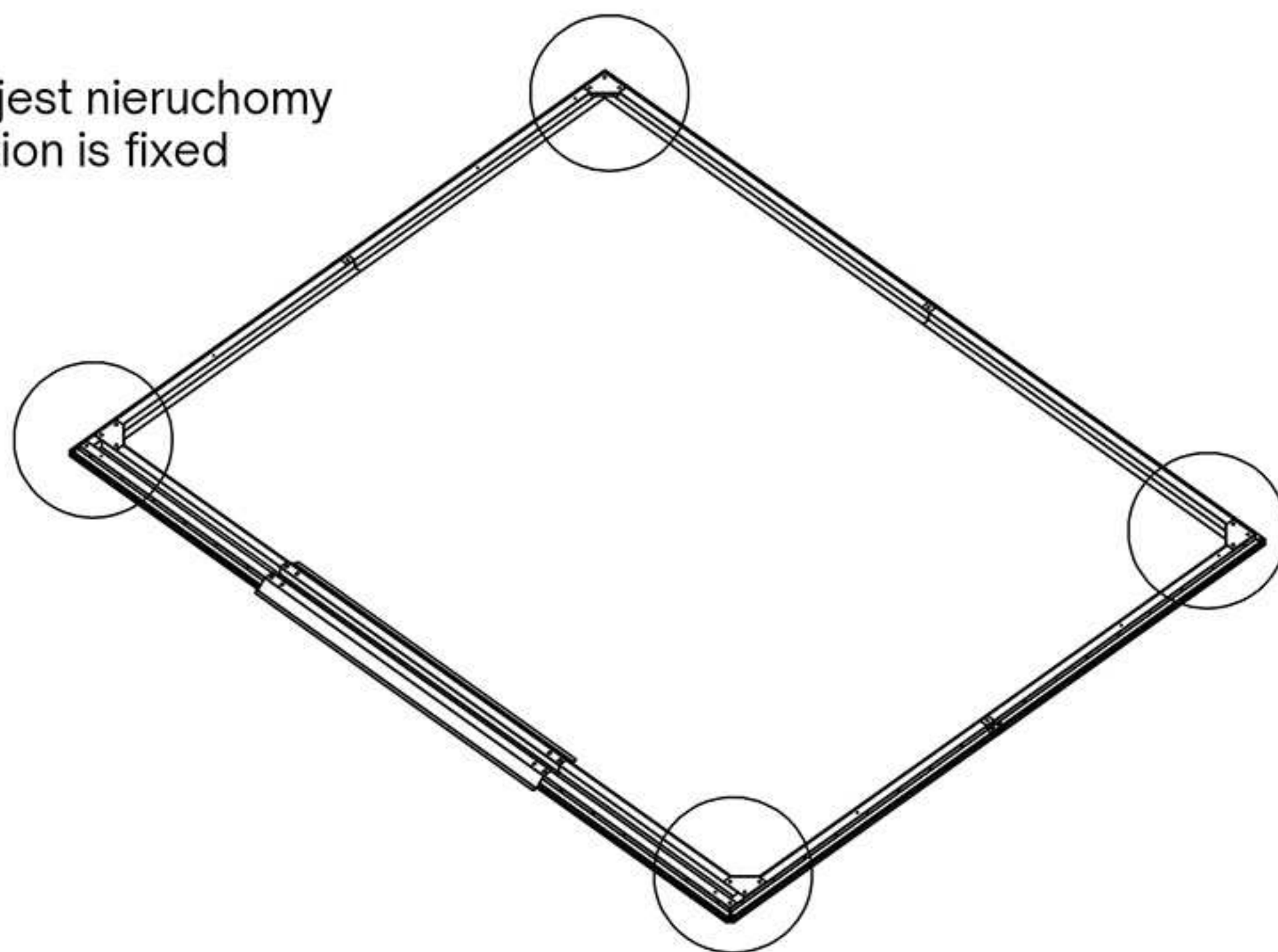
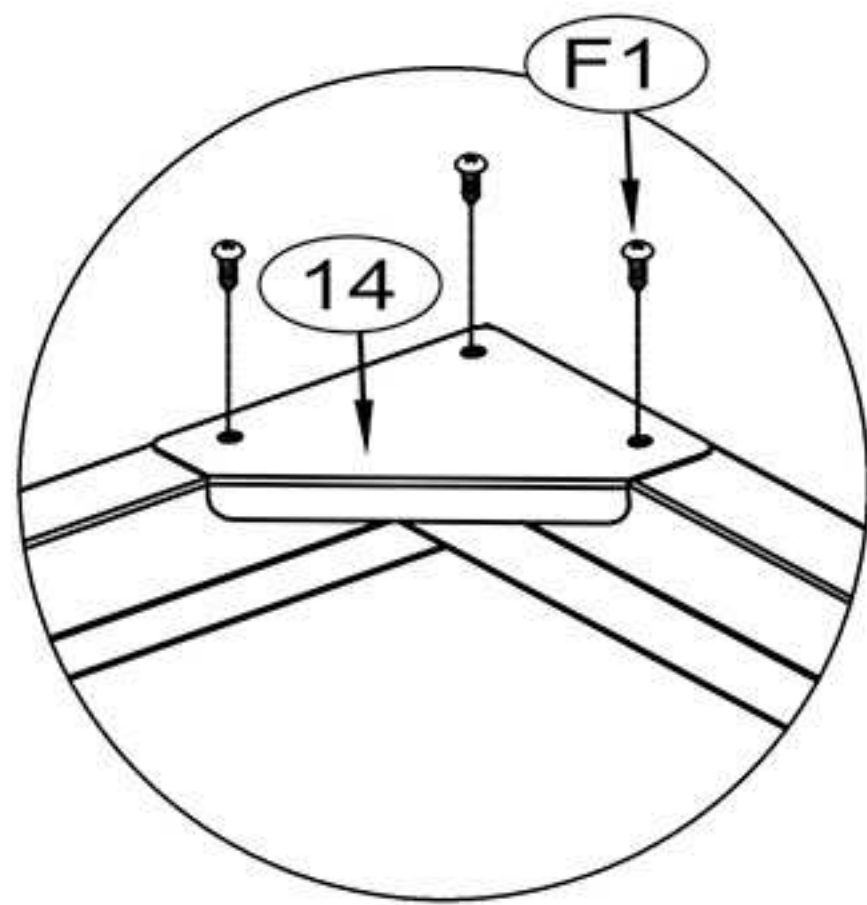

Fundament jest nieruchomy  
The foundation is fixed



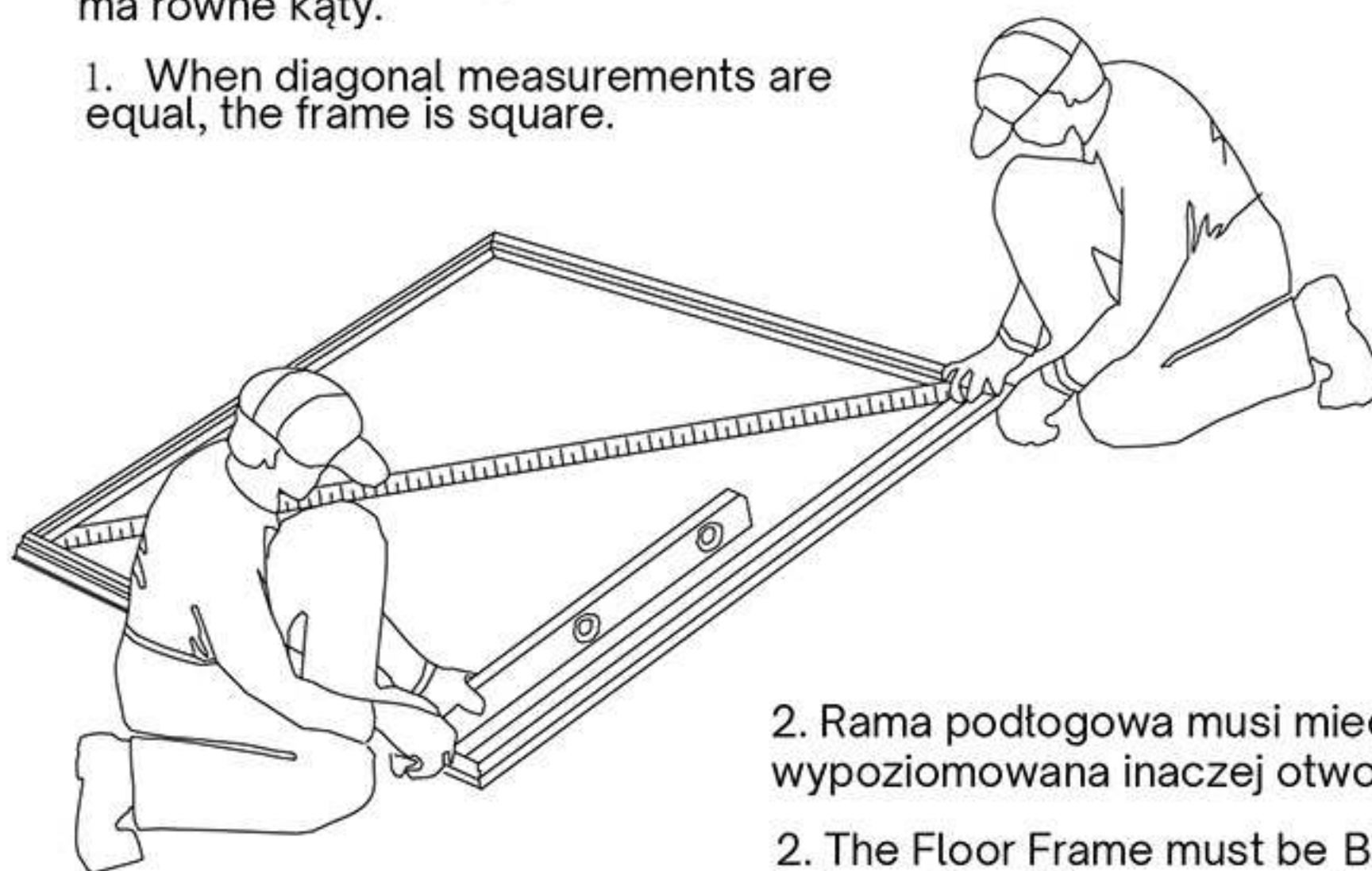



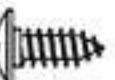

1. Kiedy przekątne są równe, ramka ma równe kąty.  
1. When diagonal measurements are equal, the frame is square.

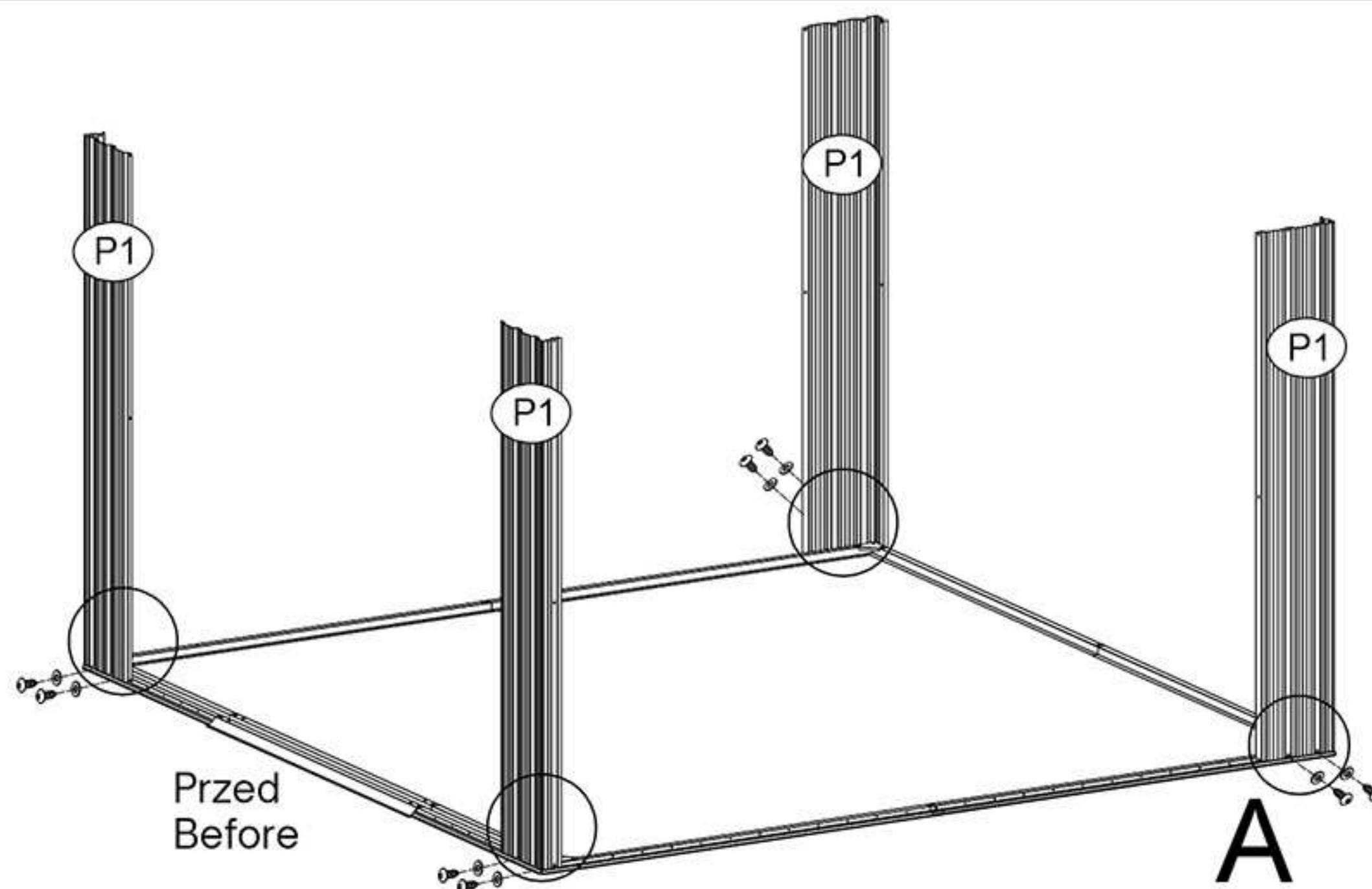
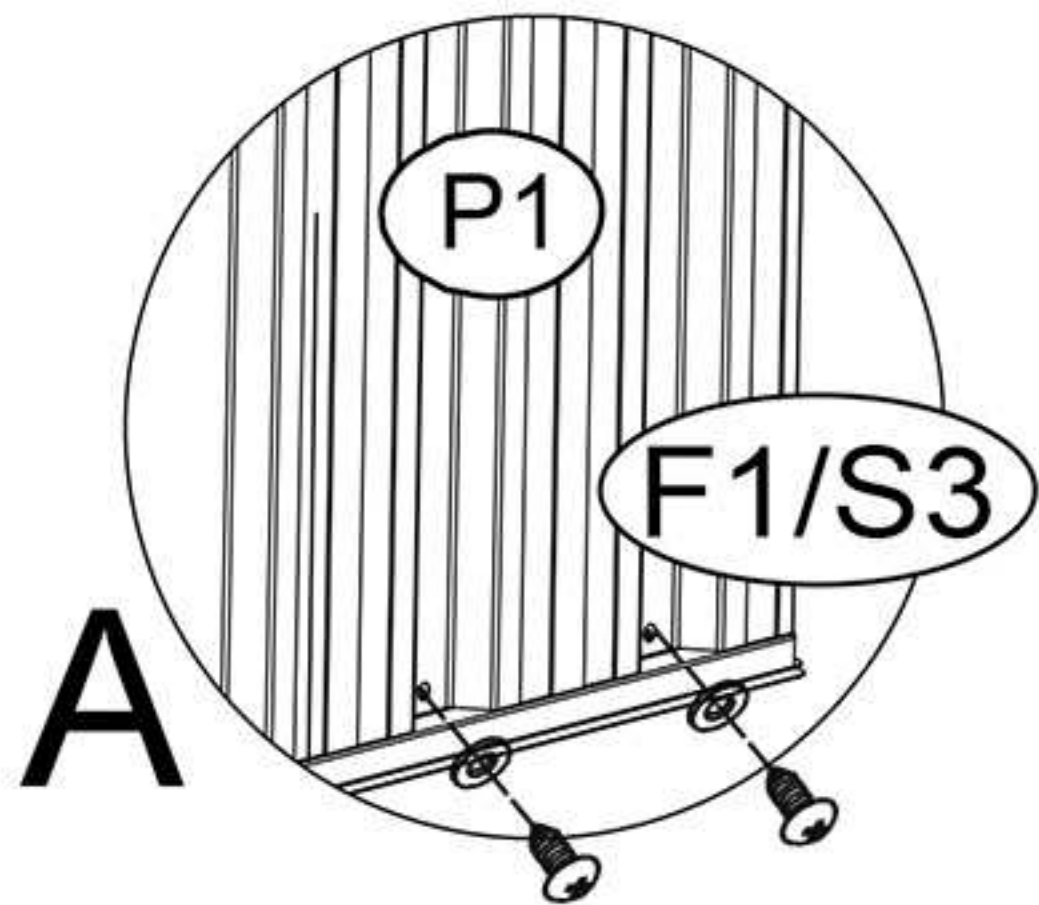



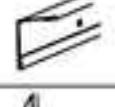

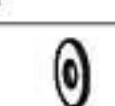

2. Rama podłogowa musi mieć równe kąty oraz musi być wypoziomowana inaczej otwory nie utożą się prawidłowo.  
2. The Floor Frame must be BOTH square and level or the holes will not line up properly.

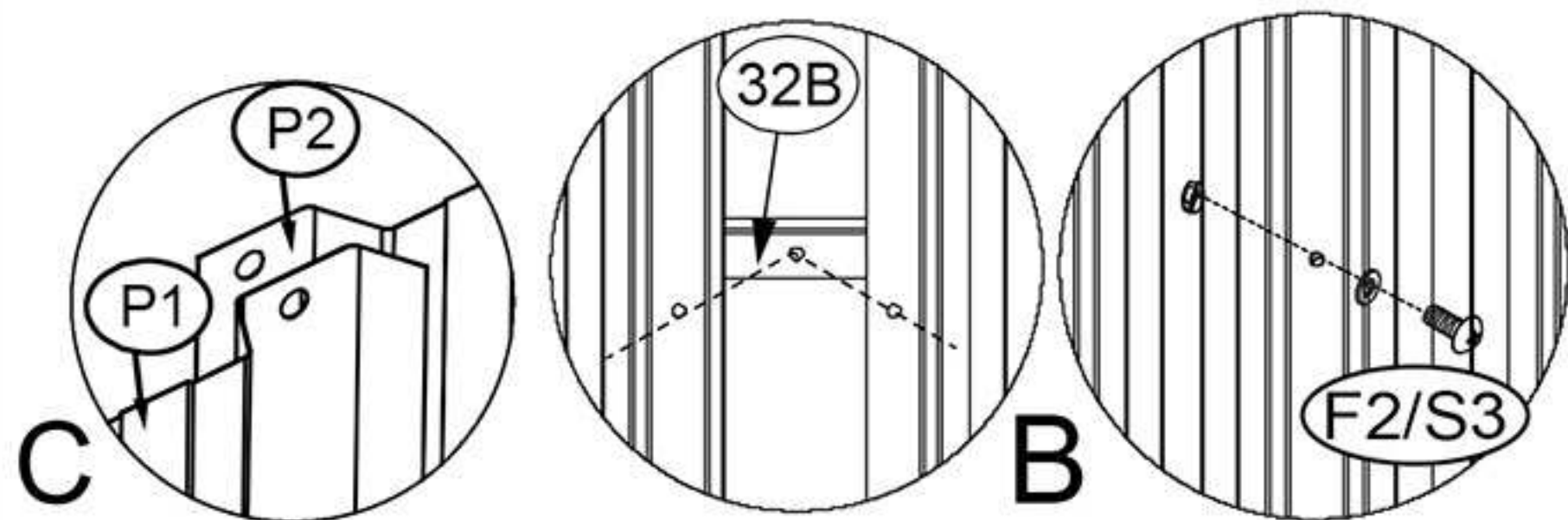
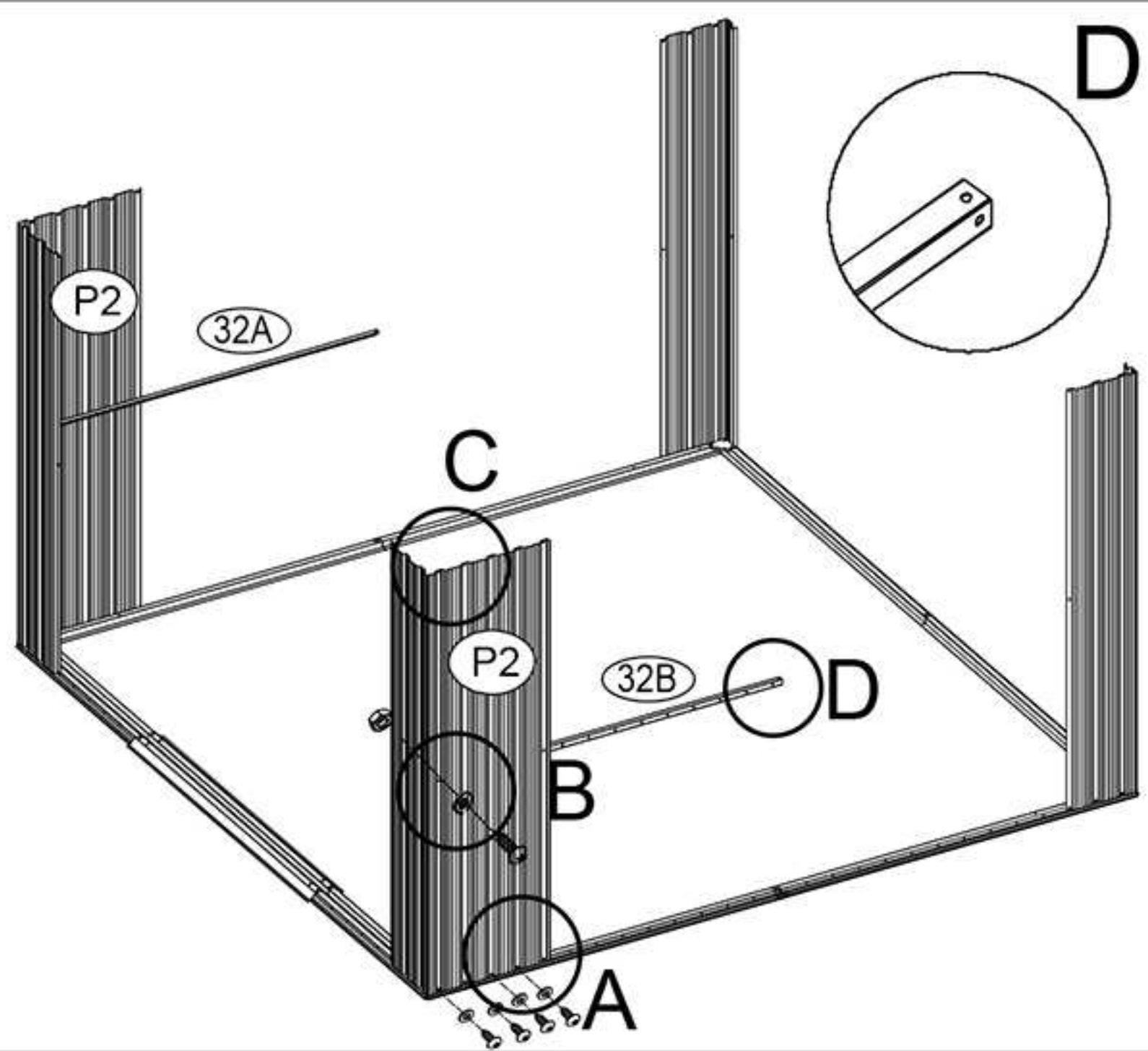
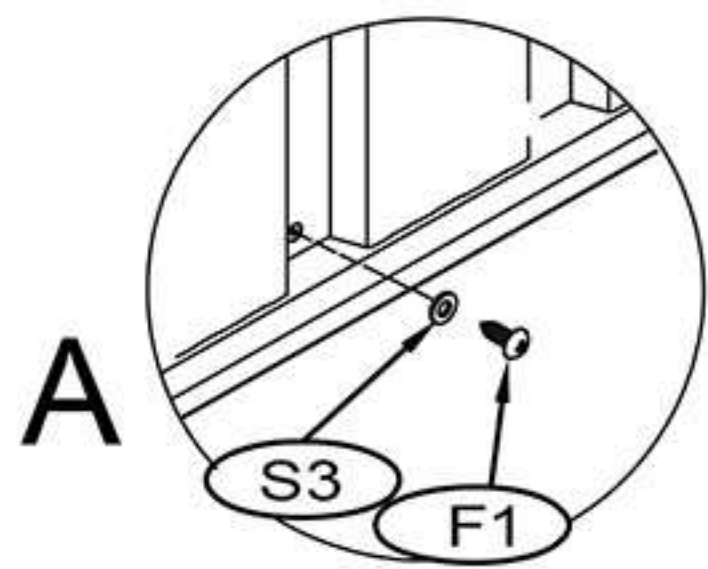
NO./NR	PART/ELEMENT	QTY./ ILOŚĆ
P1		4
F1		8
S3		8



NO./NR	PART/ELEMENT	QTY./ ILOŚĆ
P2		2
32A		1
32B		1
F1		8
F2		2
S3		10

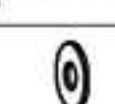



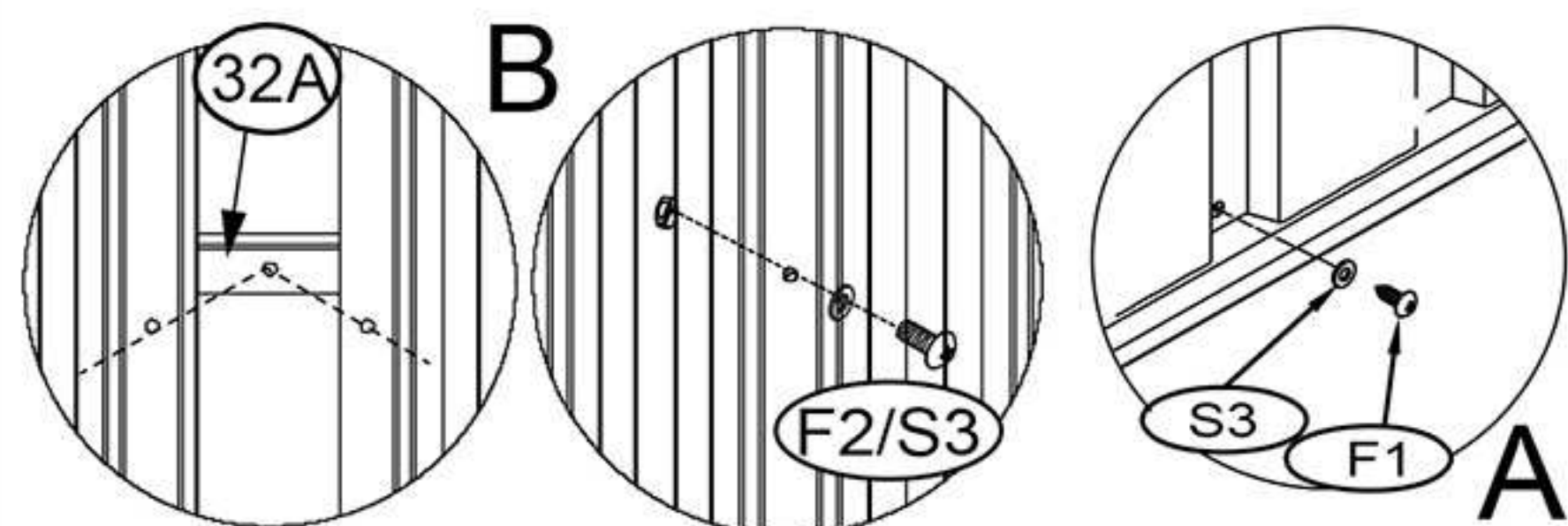
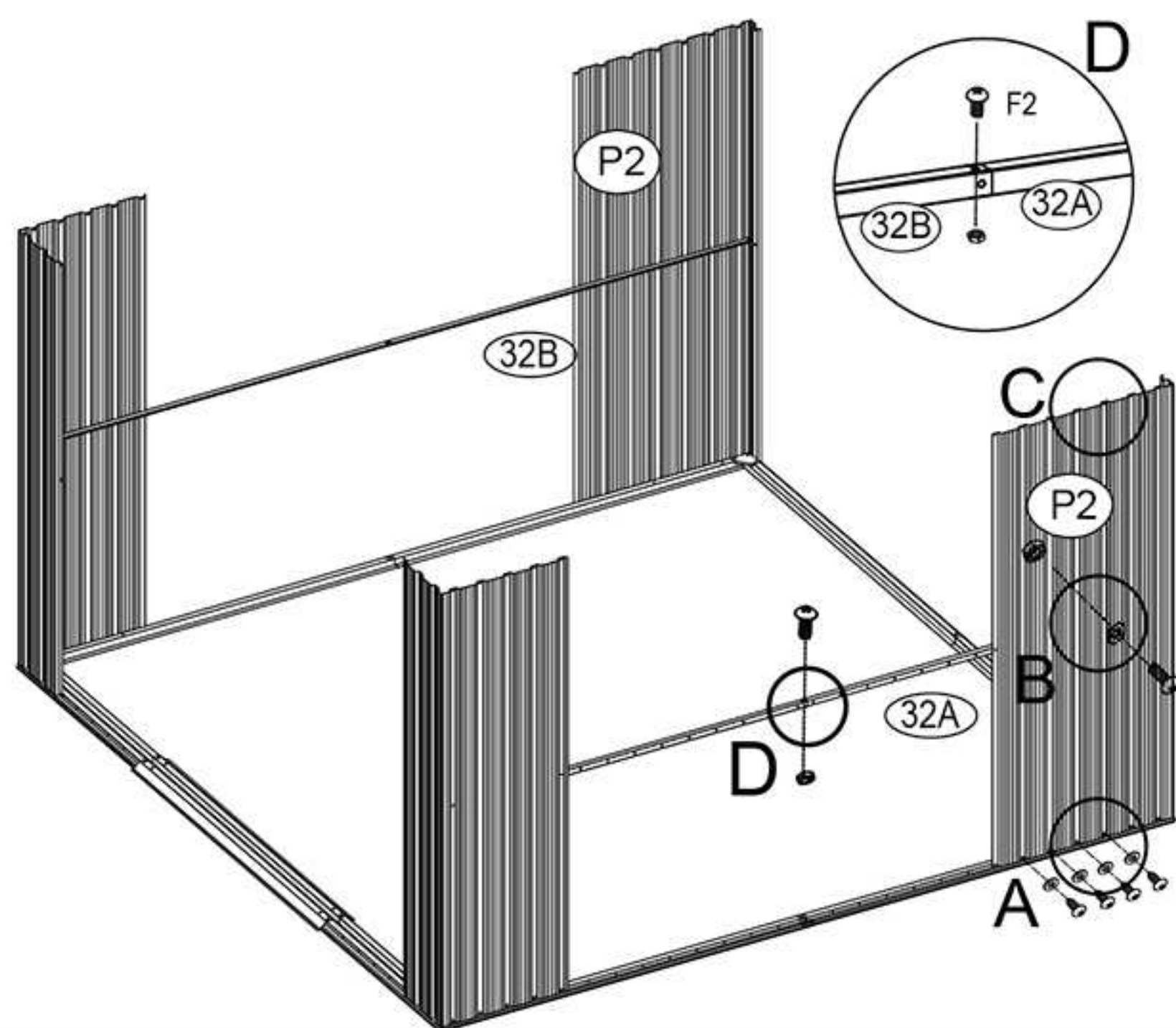
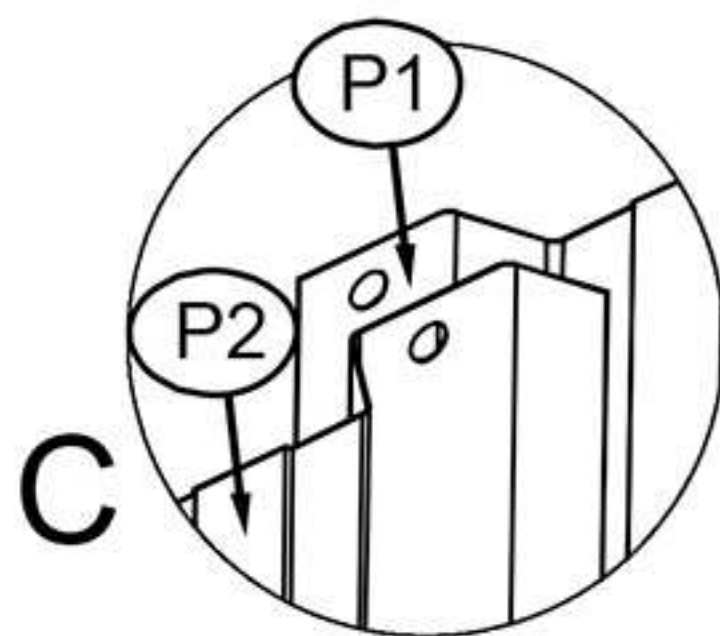

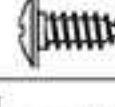
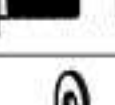
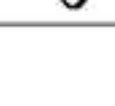
NO./NR	PART/ELEMENT	QTY./ ILOŚĆ
P2		2
32A		1
32B		1
F1		8
F2		4
S3		10

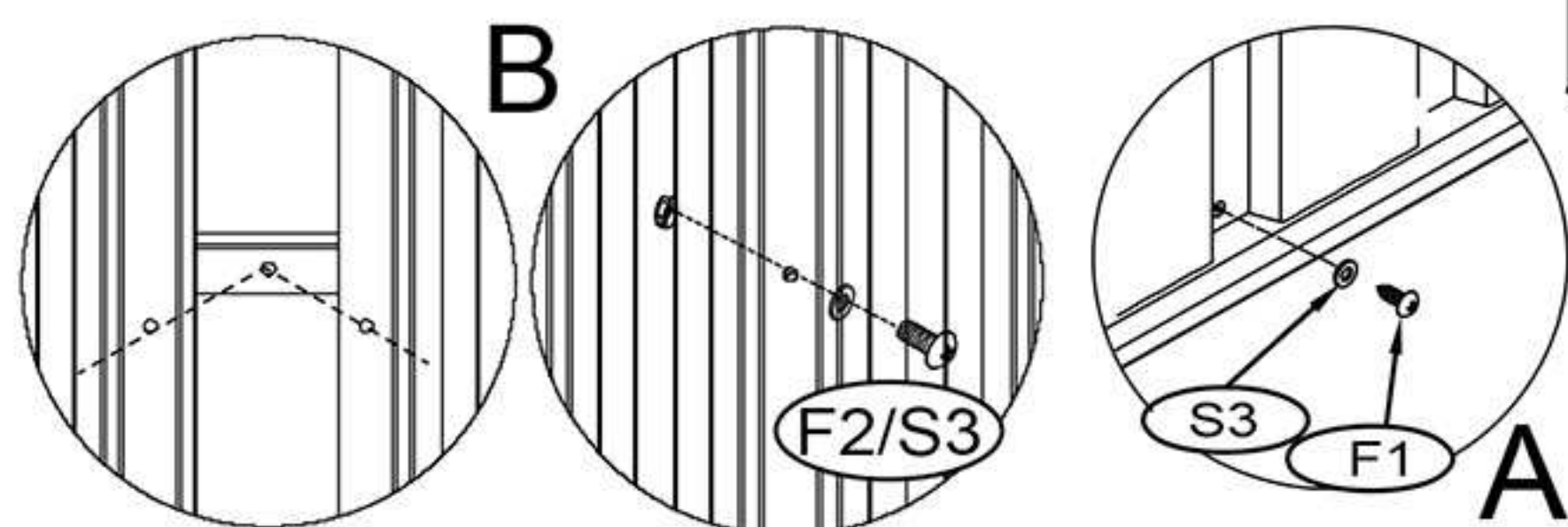
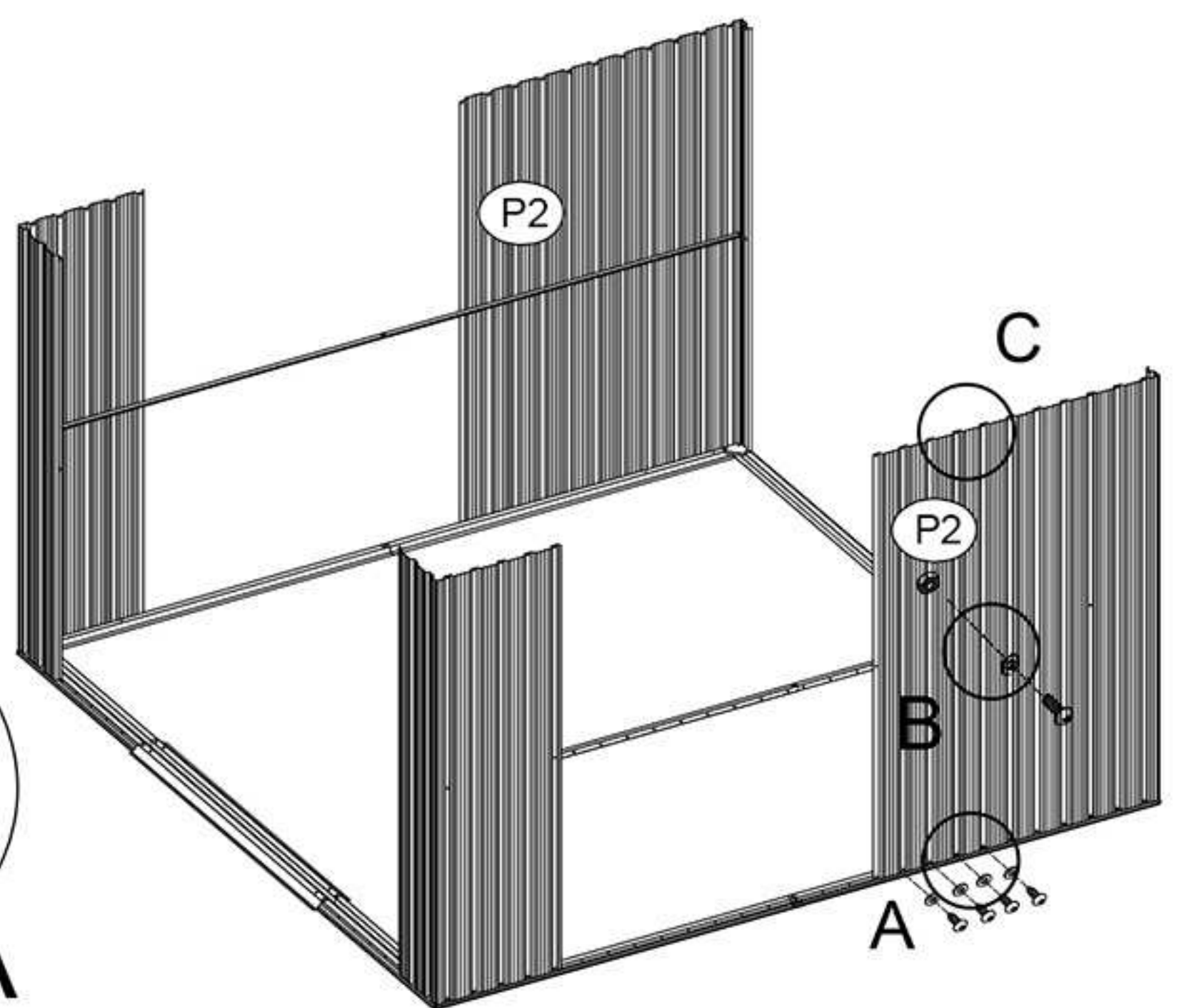
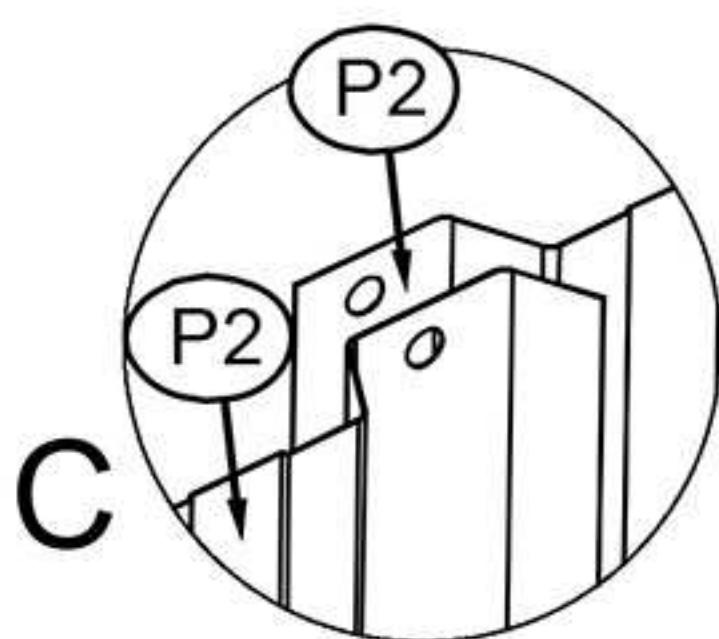



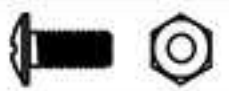

NO./NR	PART/ELEMENT	QTY./ ILOŚĆ
P2		2
F1		8
F2		2
S3		10

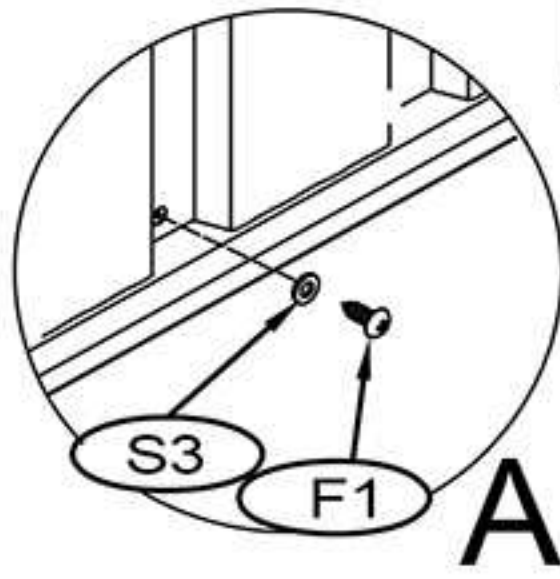
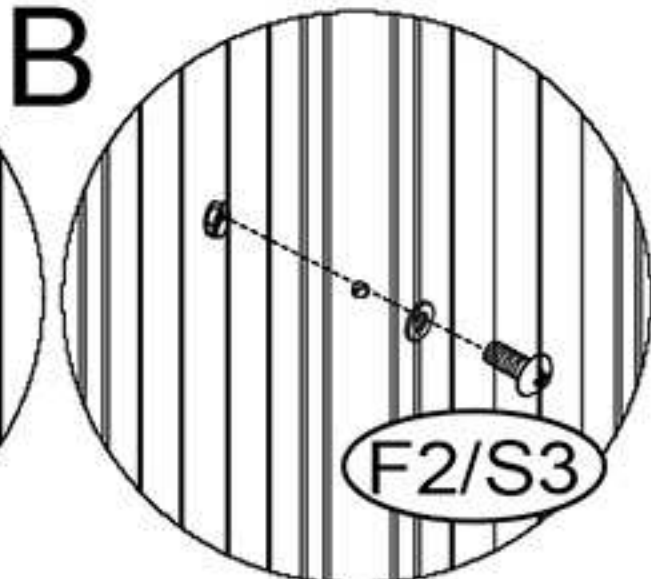
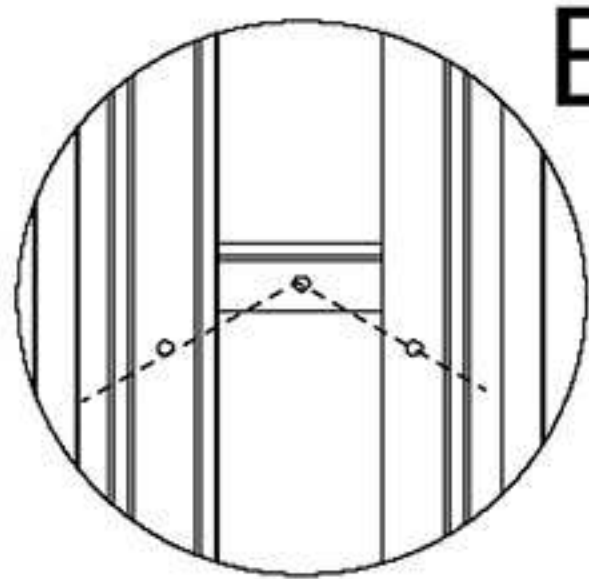
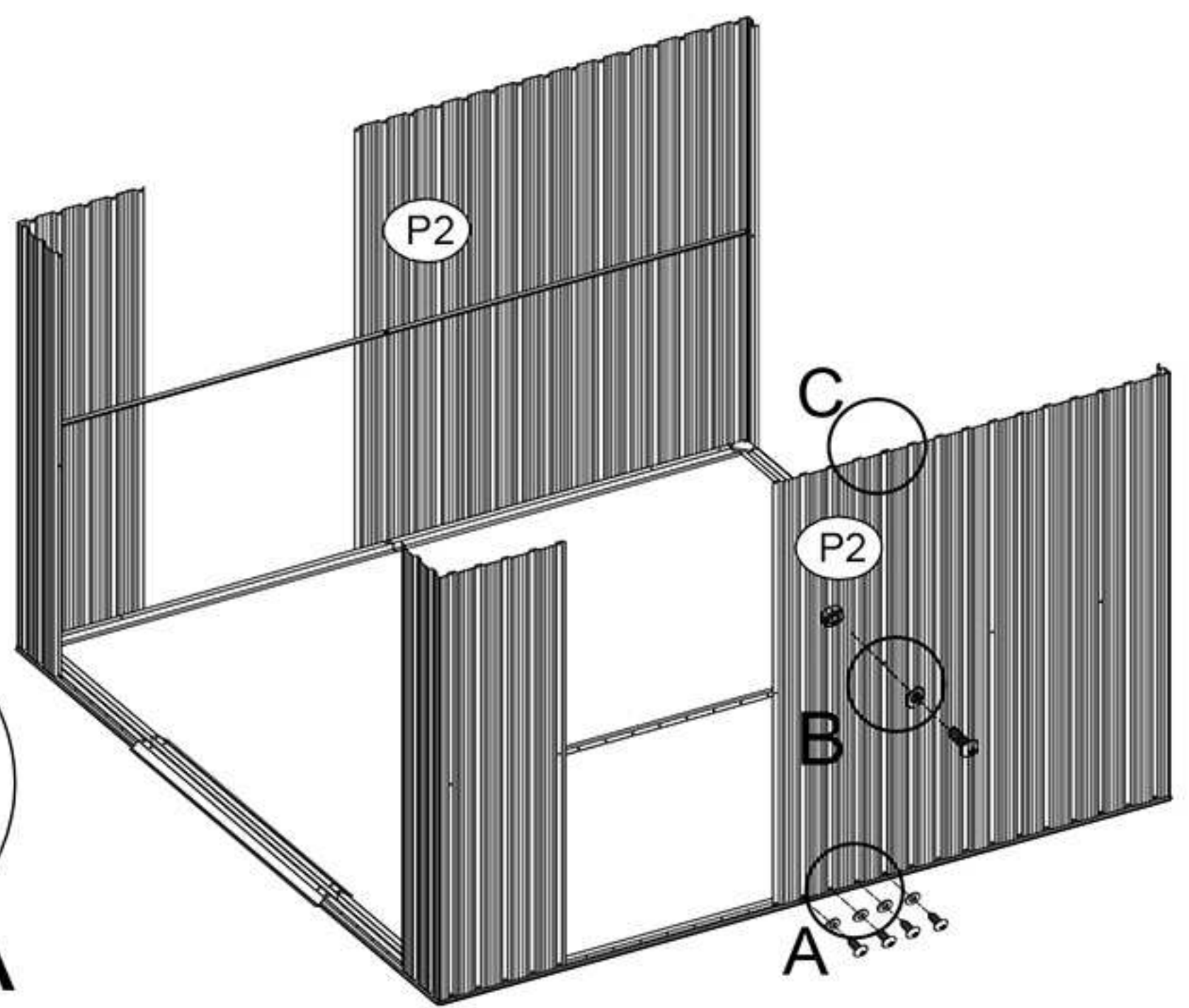
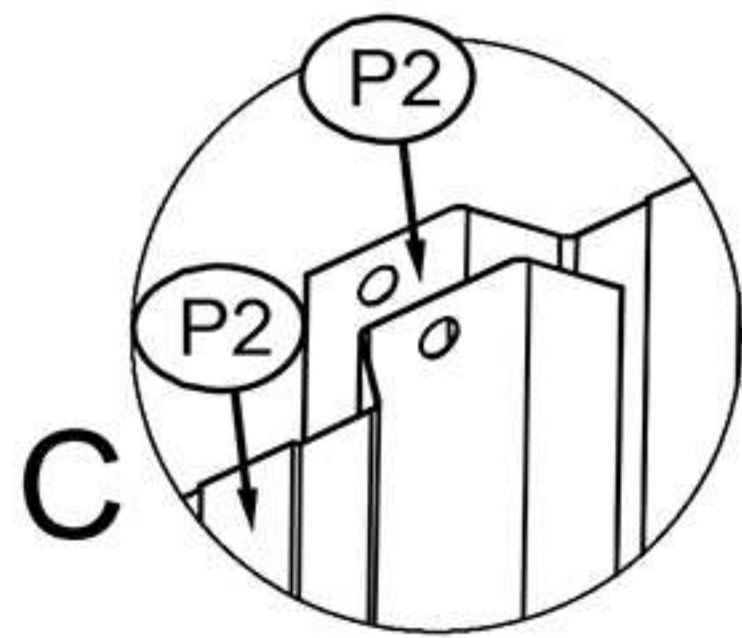





NO./NR	PART/ELEMENT	QTY./ ILOŚĆ
P2		2
F1		8
F2		2
S3		10

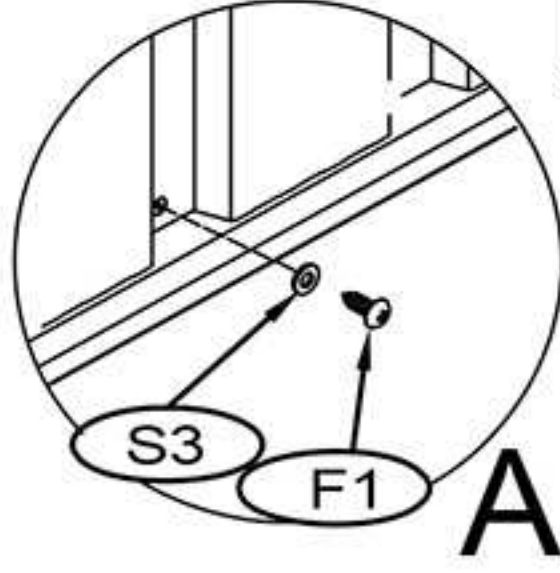
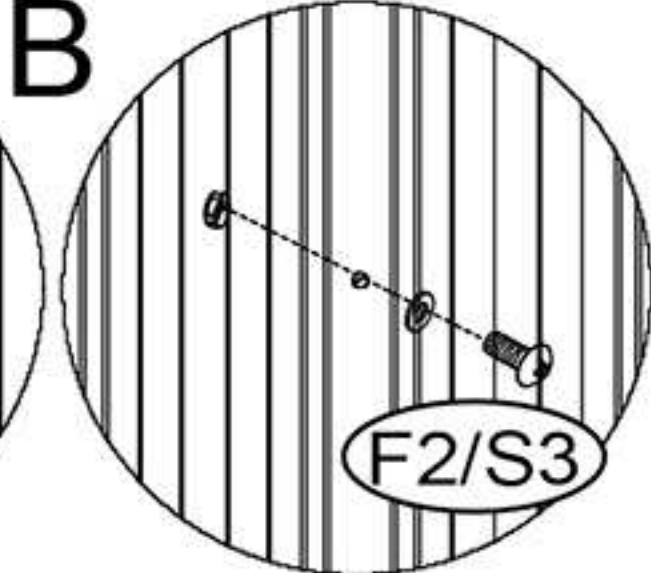
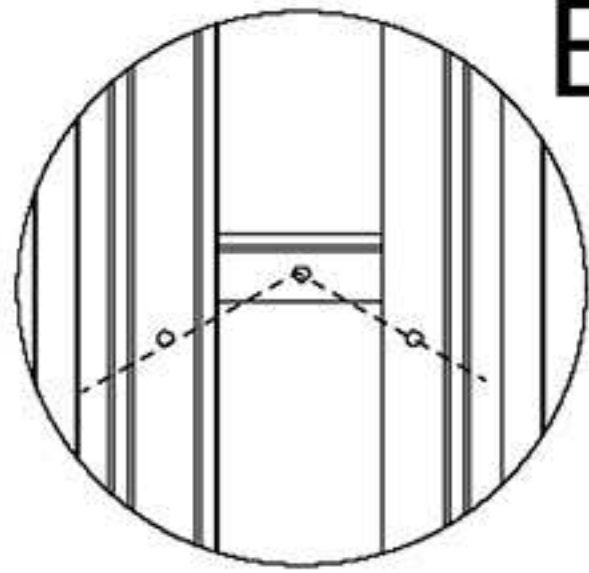
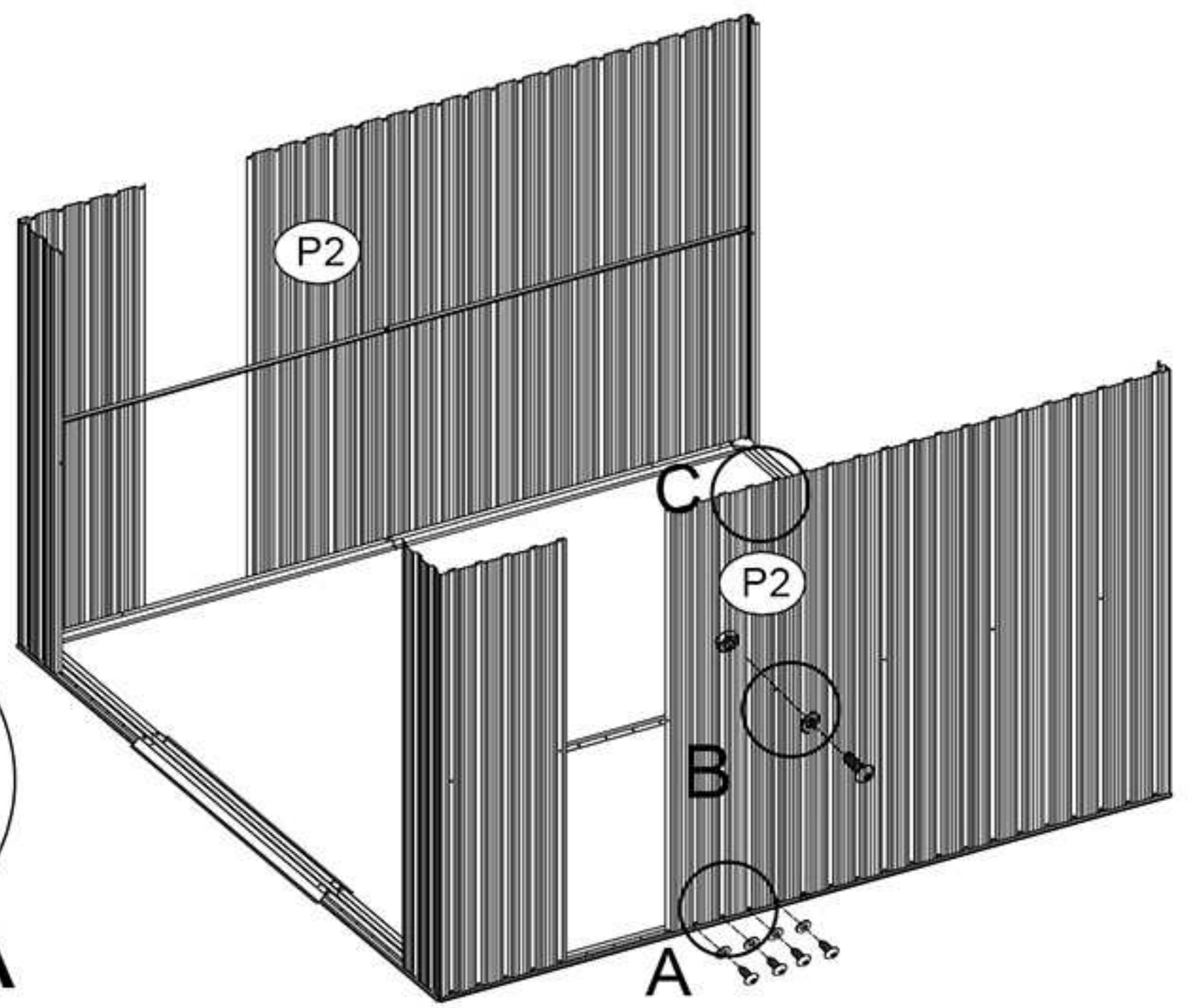
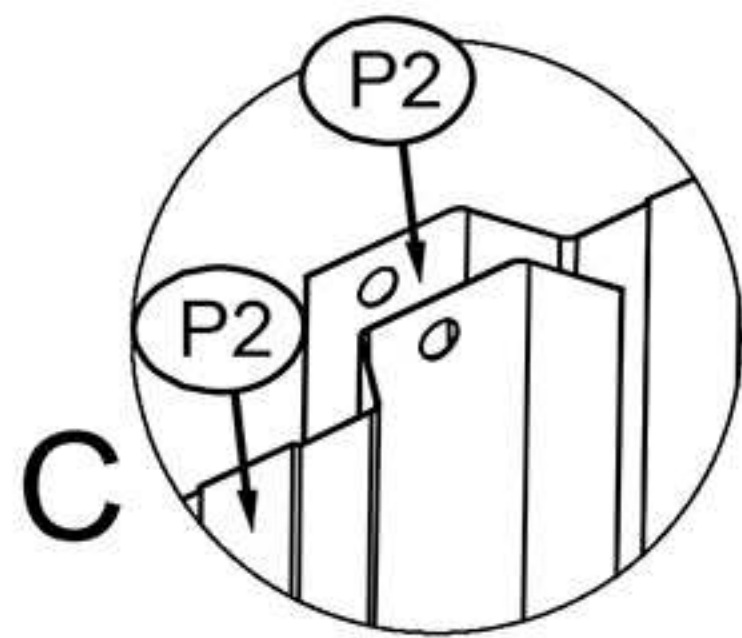

NO./NR	PART/ELEMENT	QTY./ ILOŚĆ
P2		2
F1		8
F2		2
S3		10



NO./NR	PART/ELEMENT	QTY./ ILOŚĆ
P2		2
F1		10
F2		4
S3		14

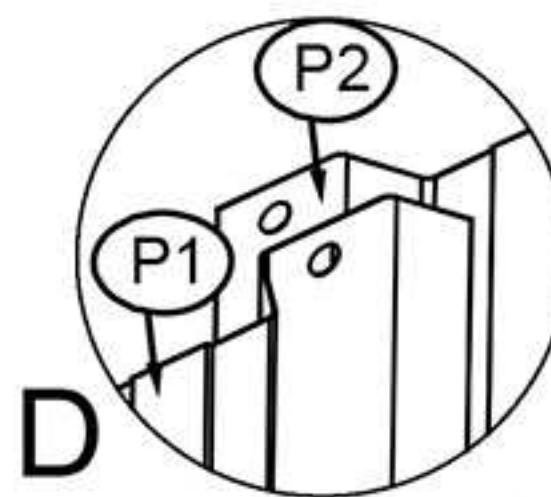
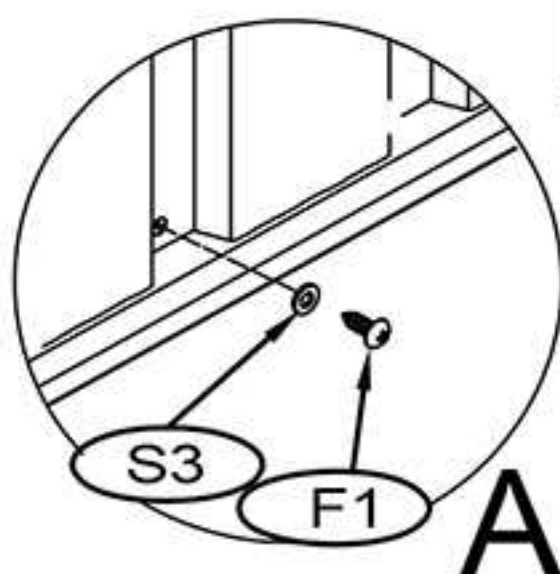
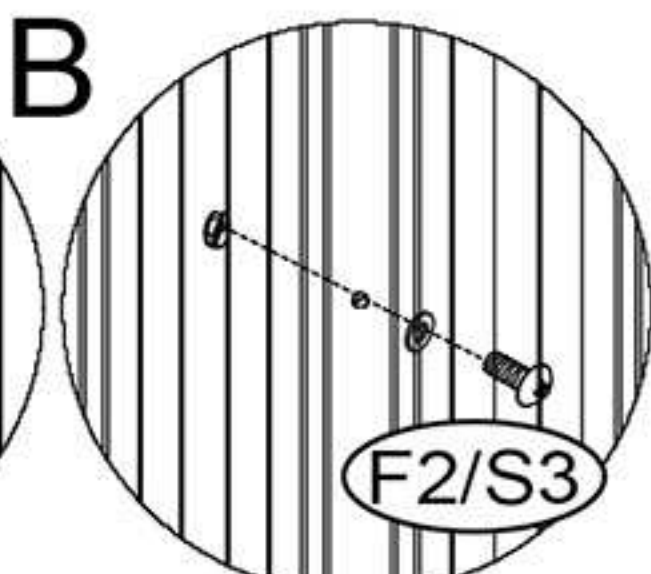
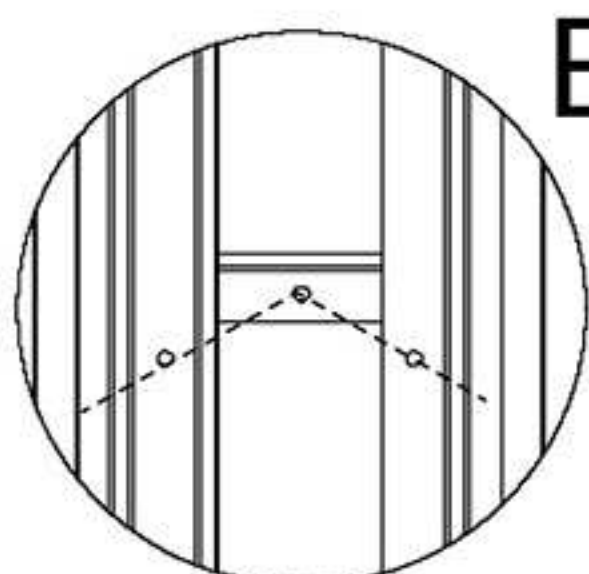
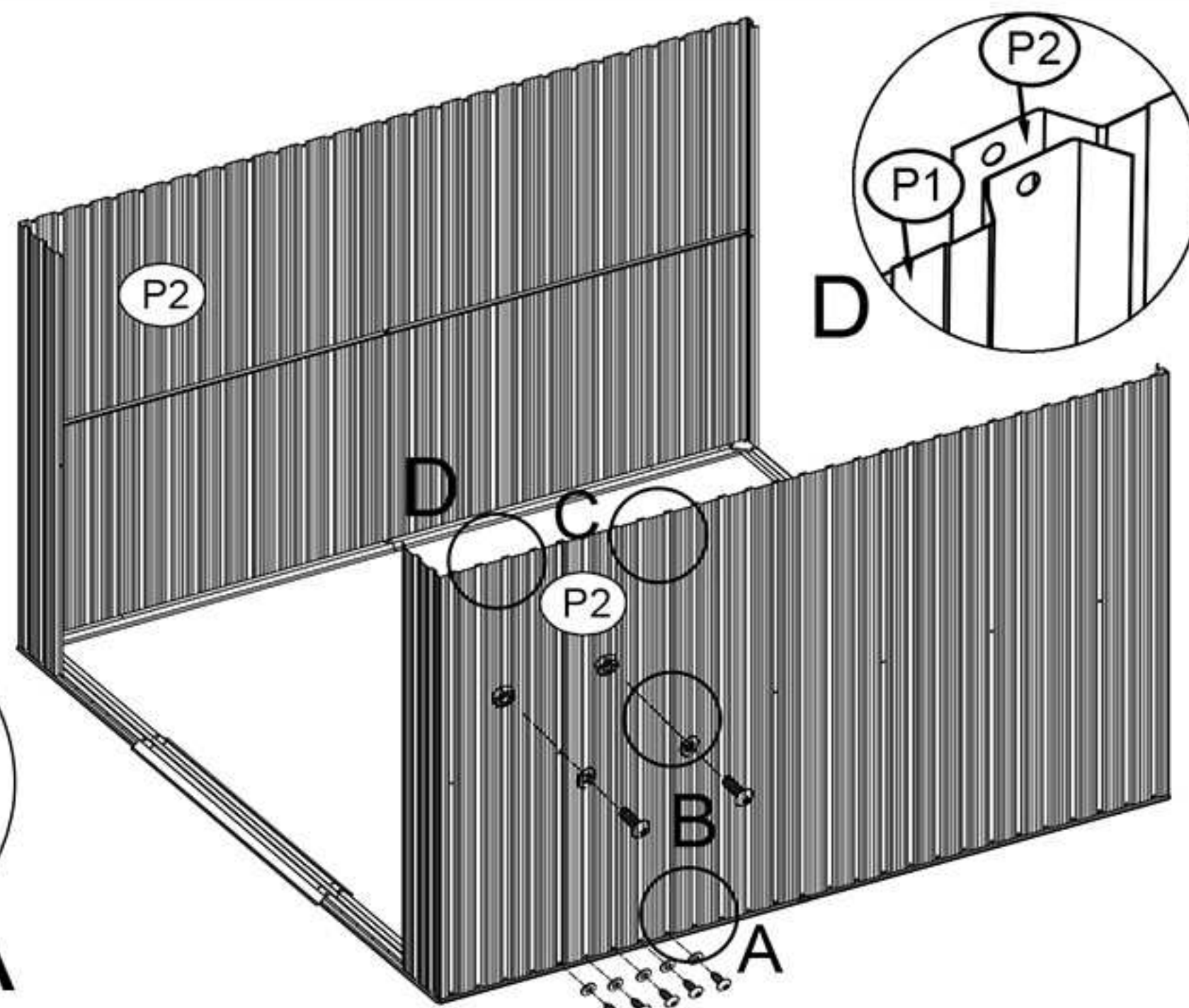
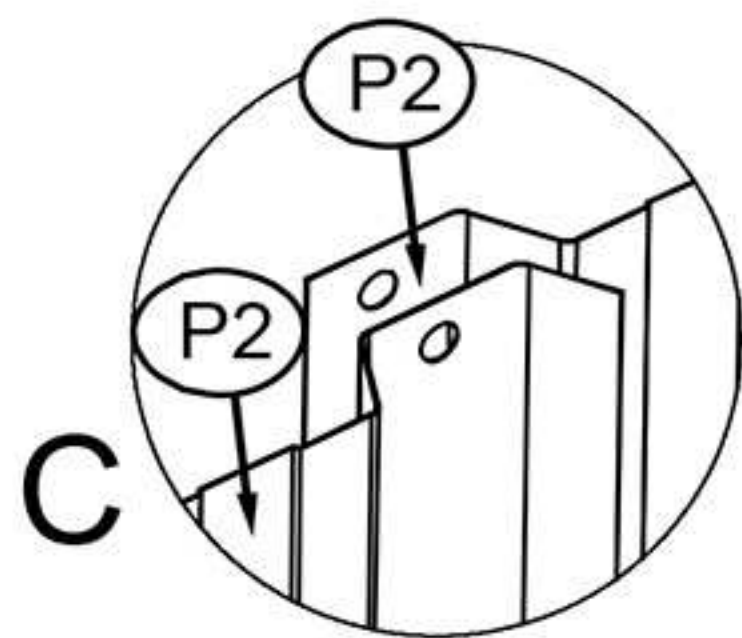

NO./NR	PART/ELEMENT	QTY./ ILOŚĆ
34L		1
34R		1
F1		2

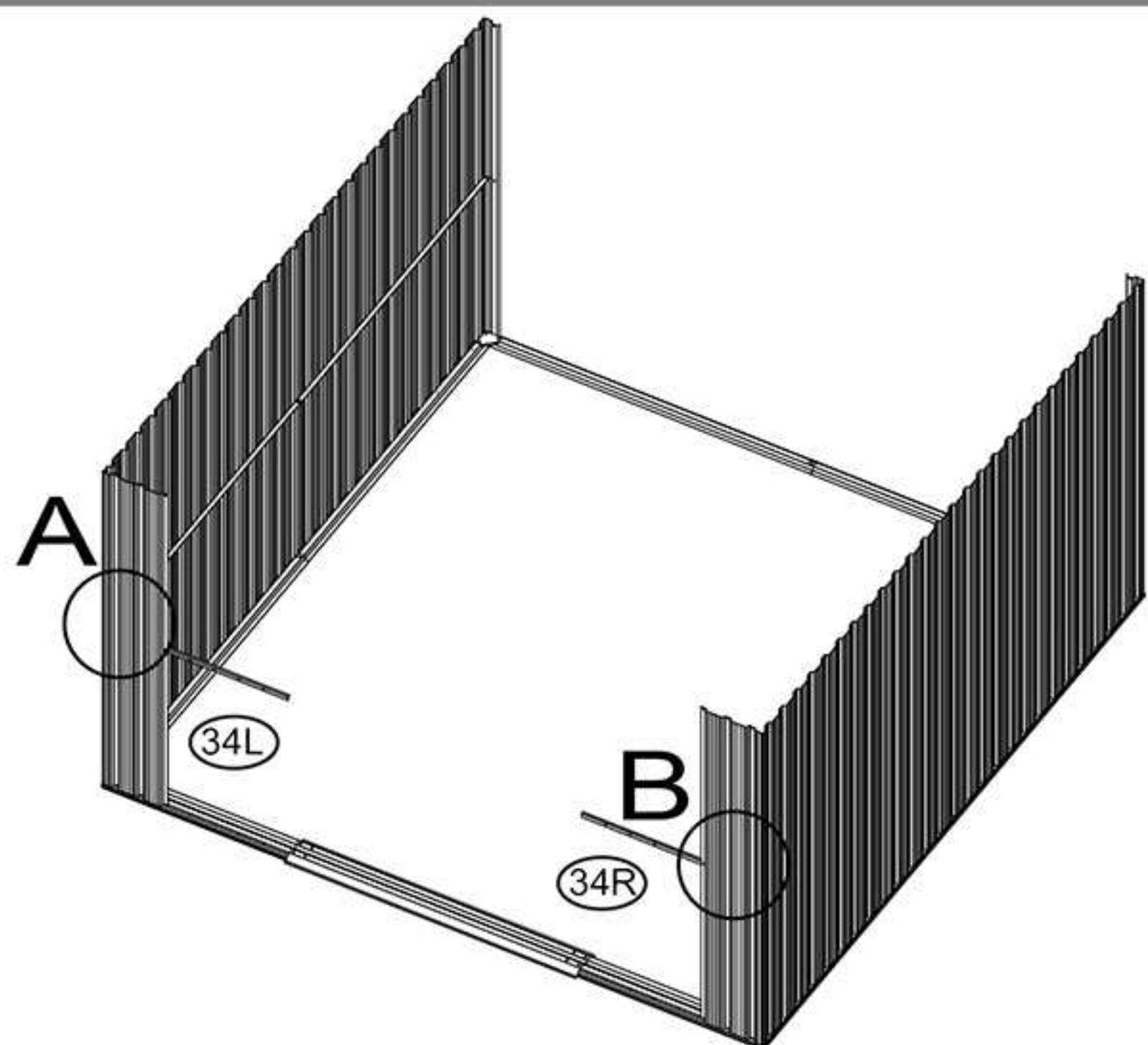
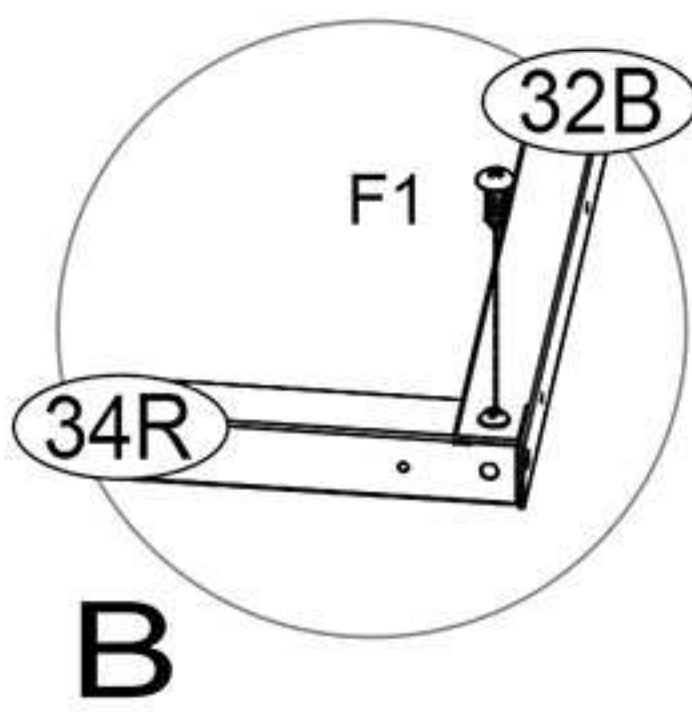
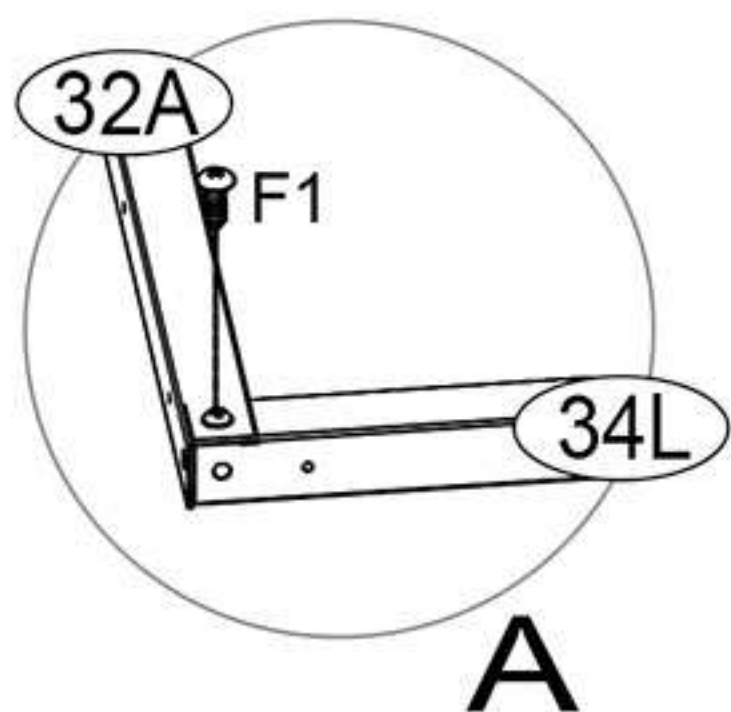

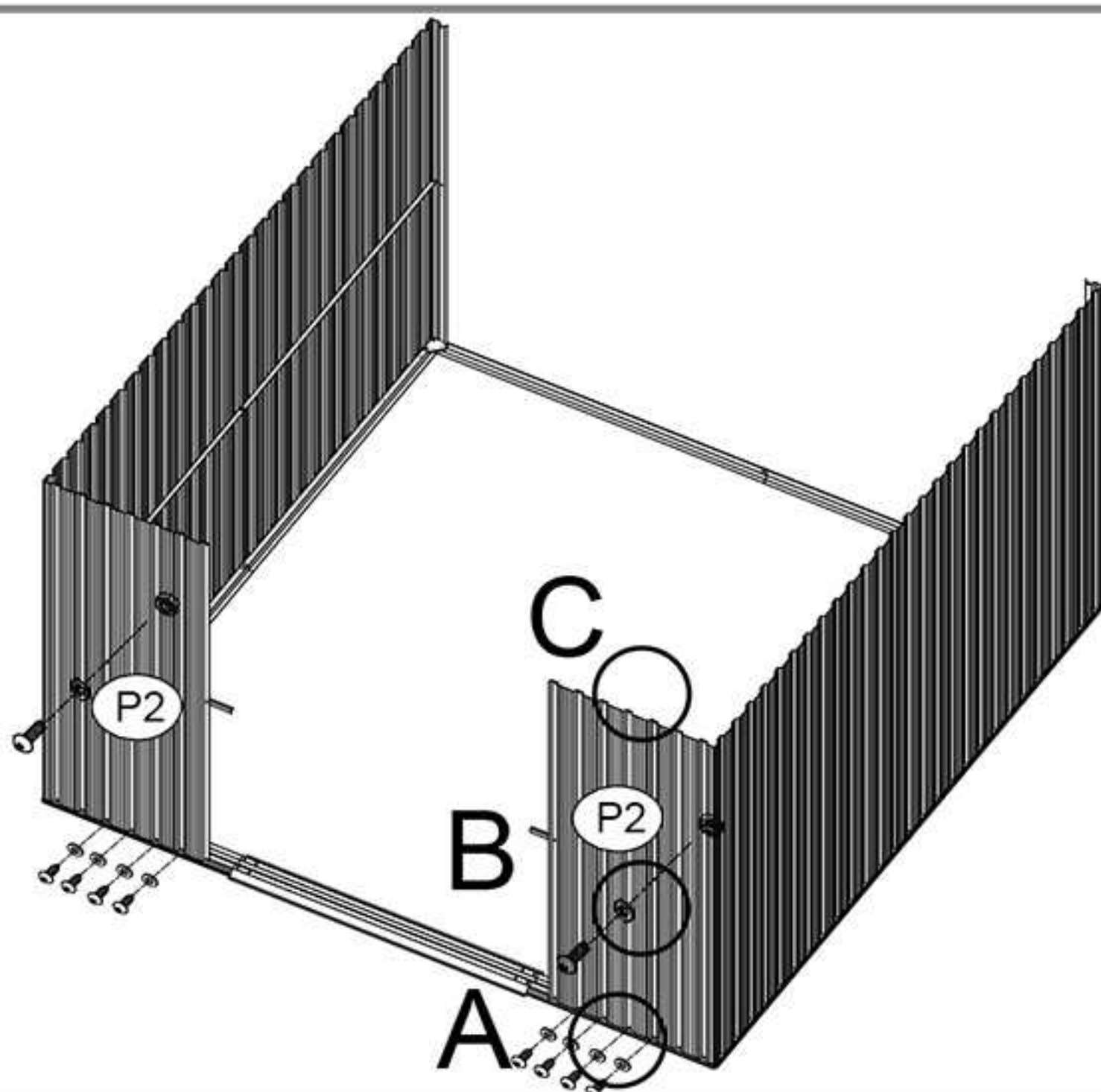
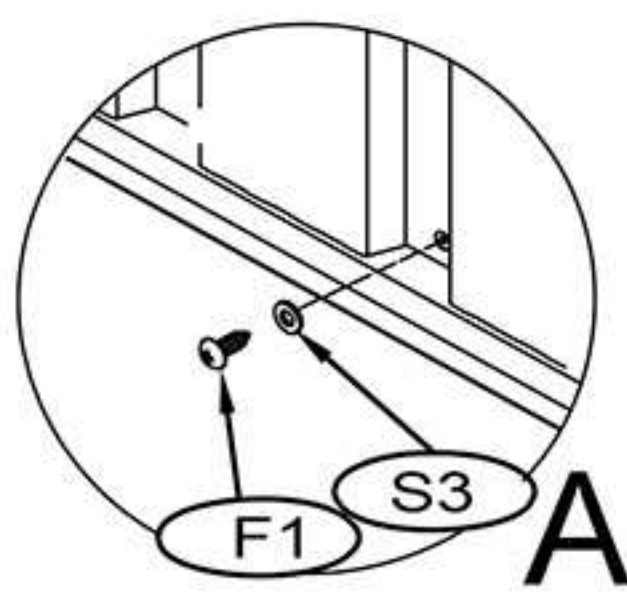
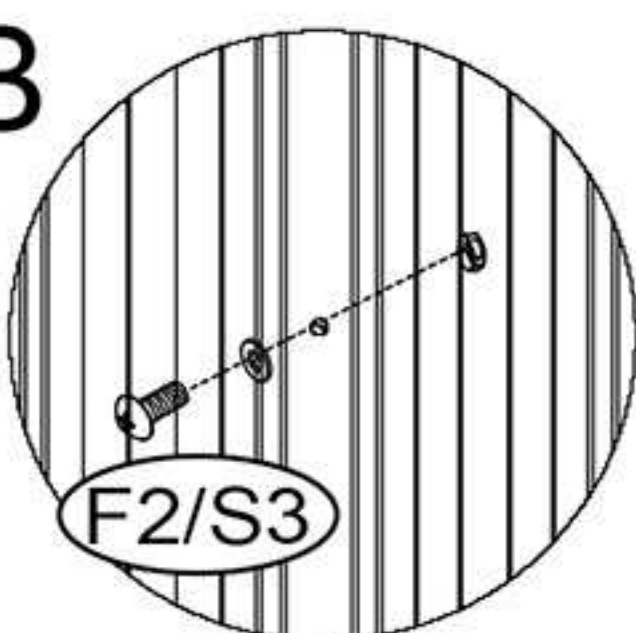
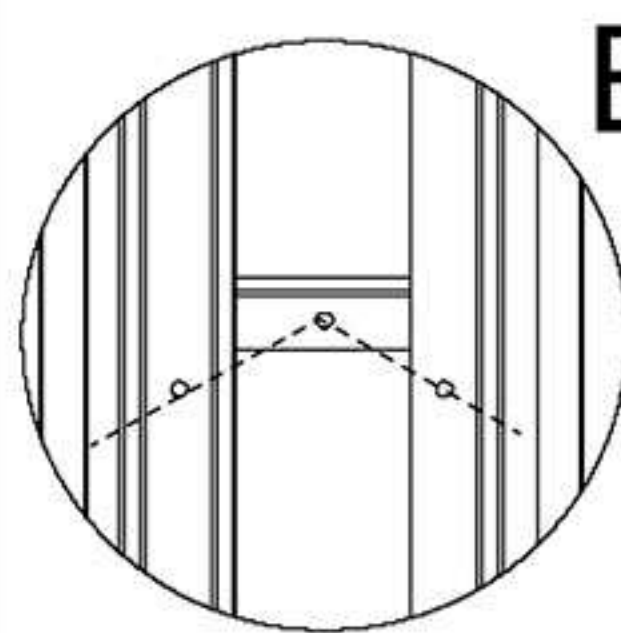
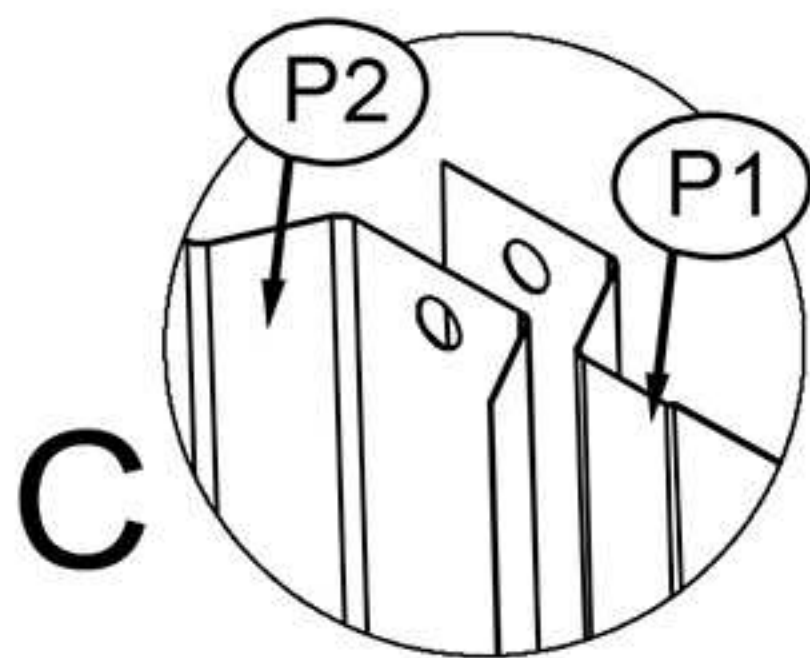

NO./NR	PART/ELEMENT	QTY./ ILOŚĆ
P2		2
F1		8
F2		2
S3		10



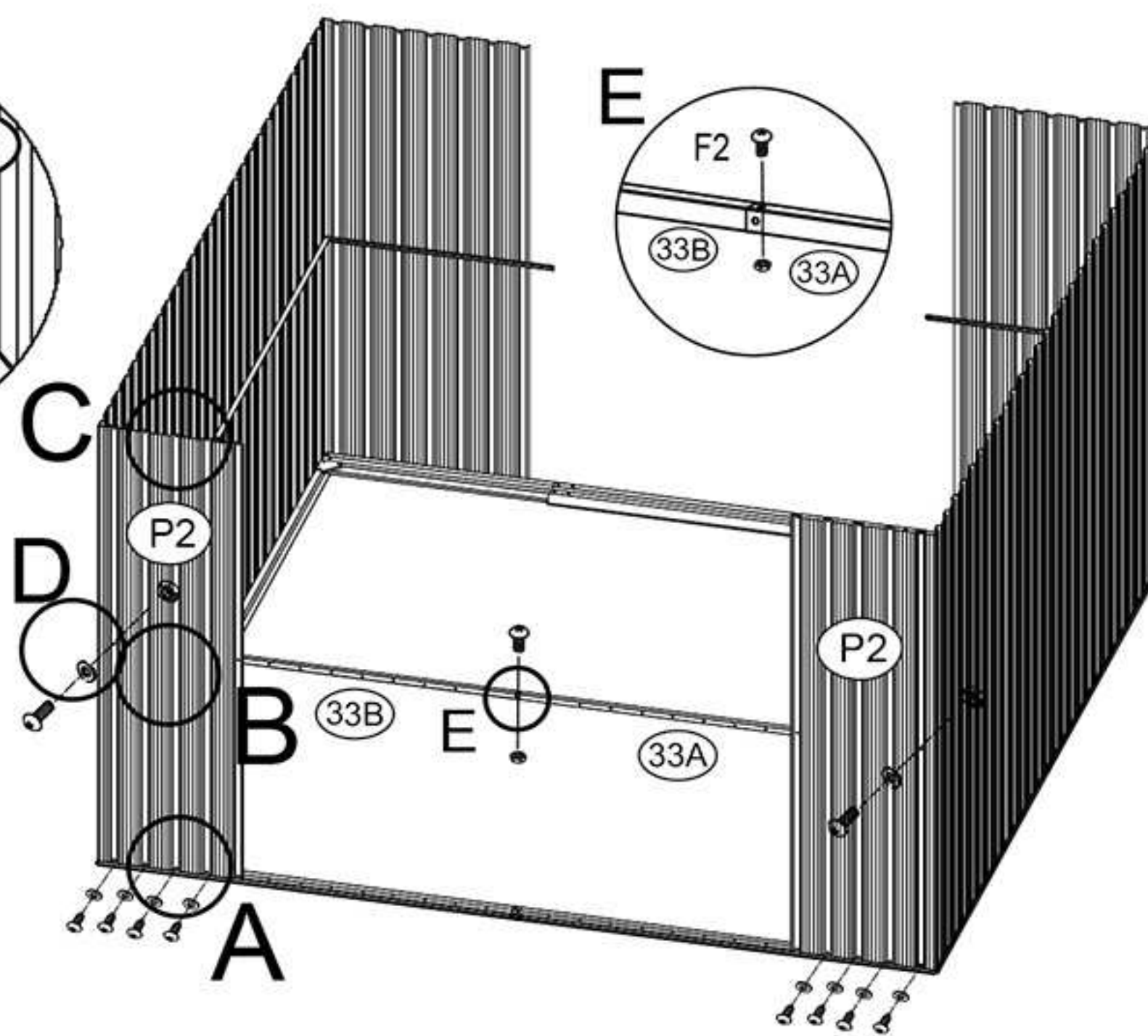
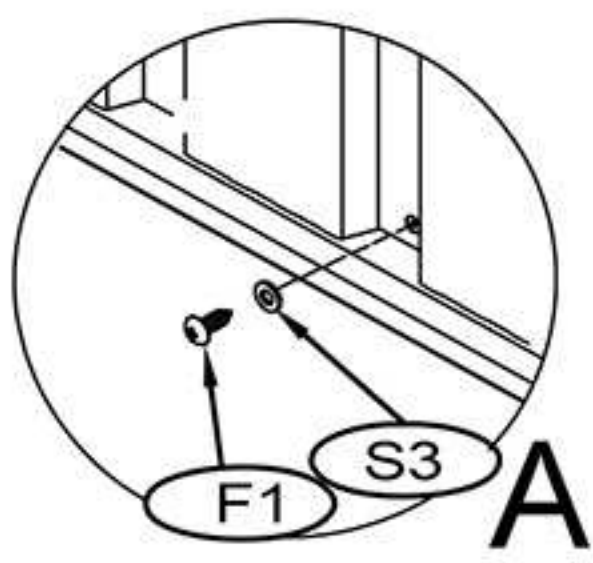
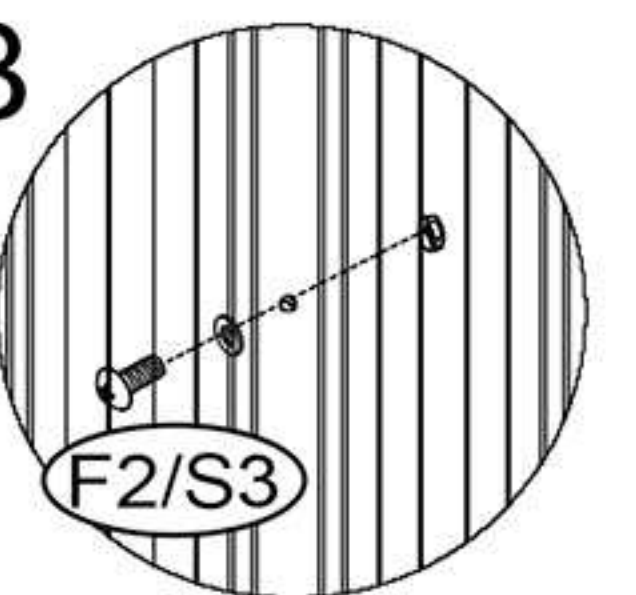
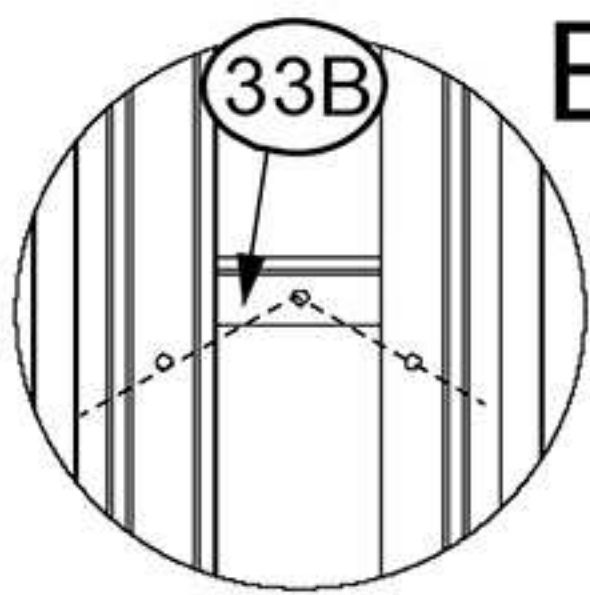
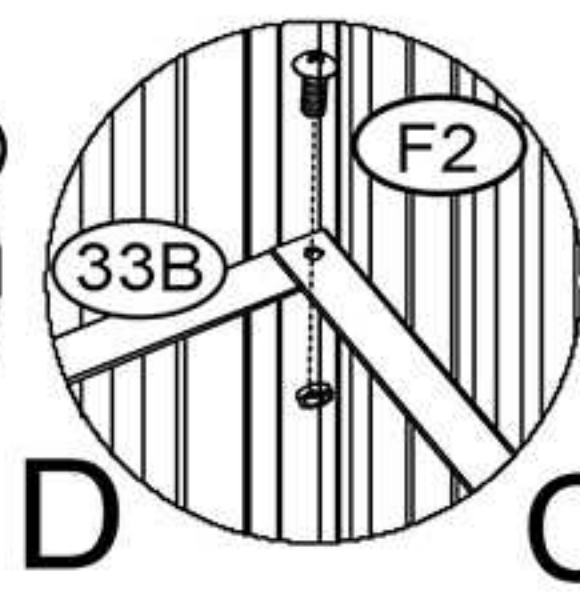
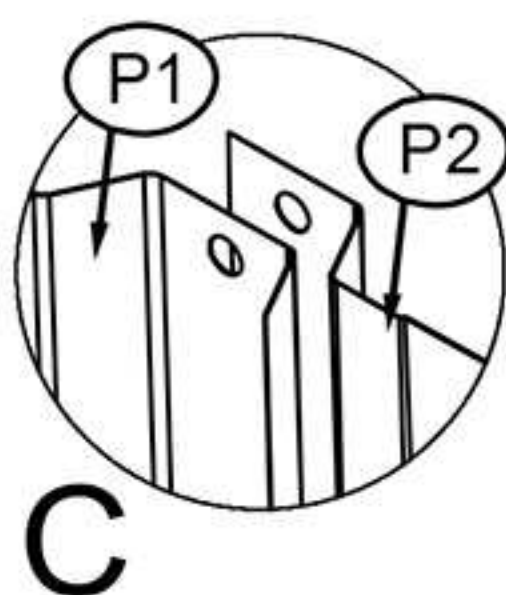

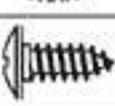
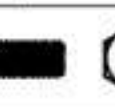

NO./NR	PART/ELEMENT	QTY./ ILOŚĆ
P2		2
33A		1
33B		1
F1		8
F2		5
S3		10

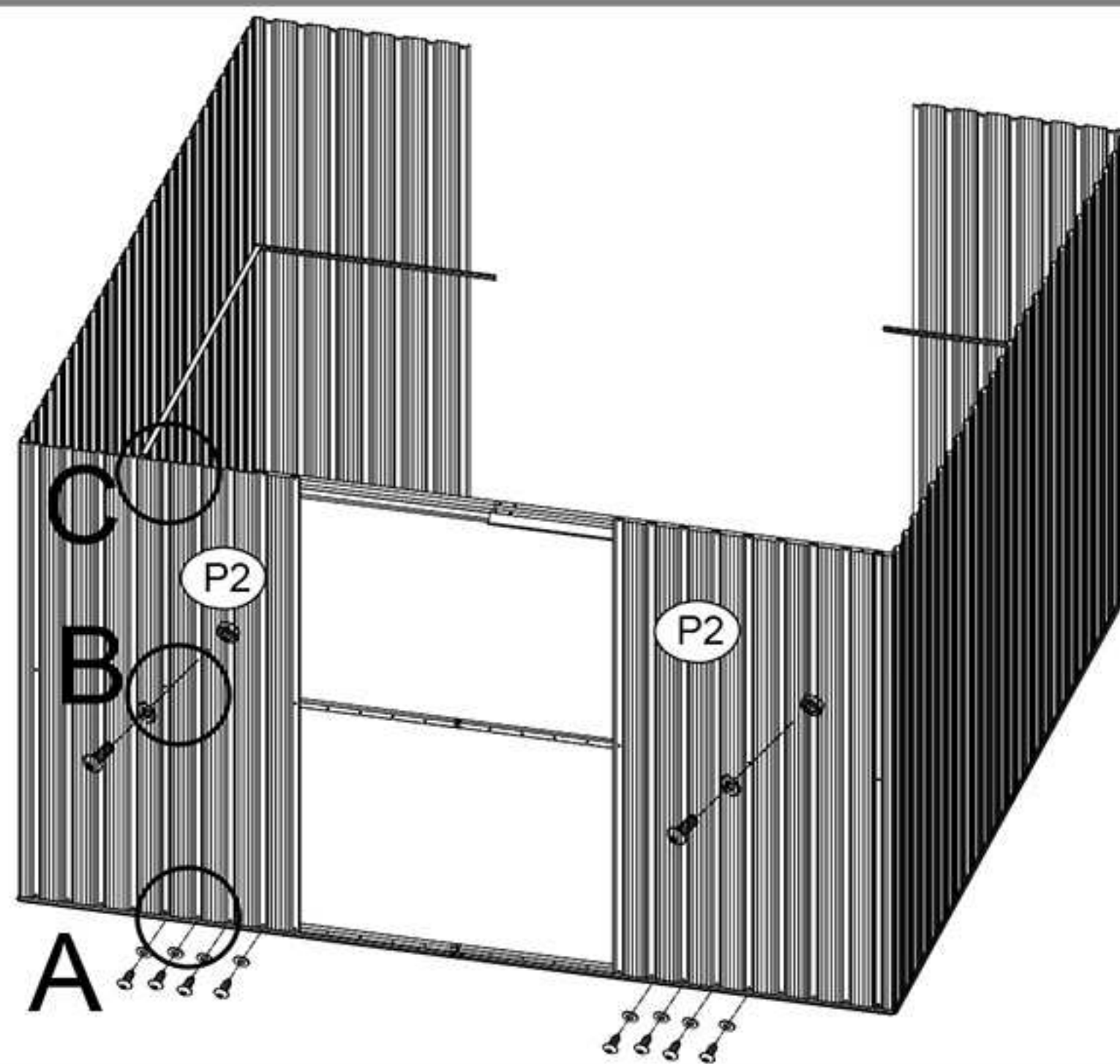
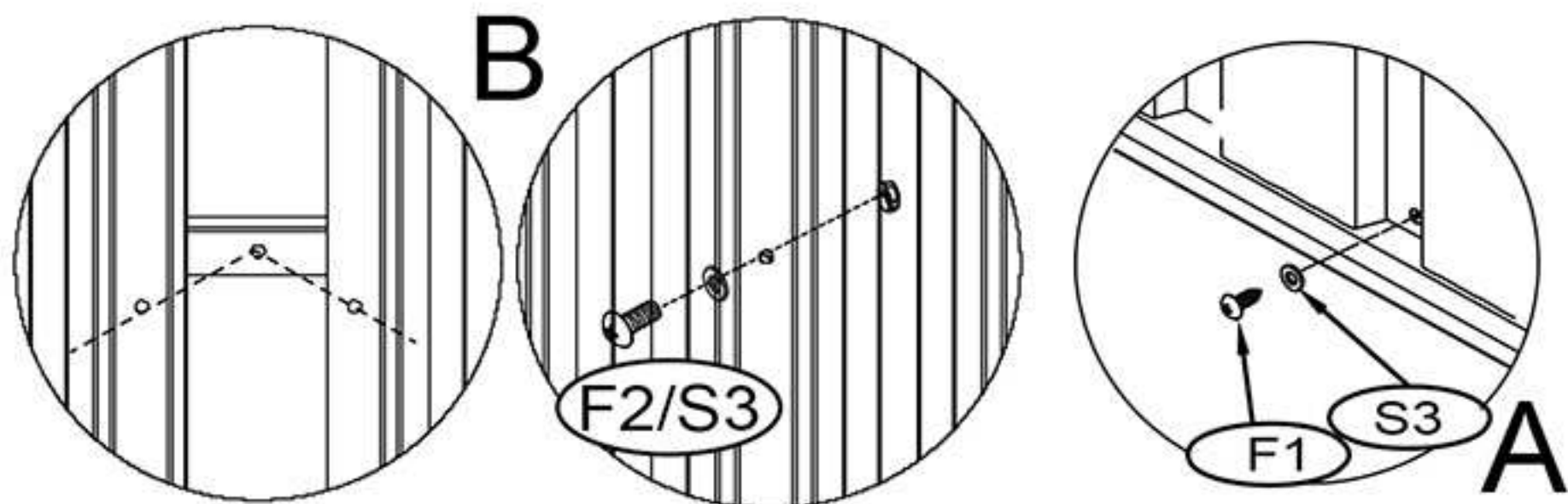
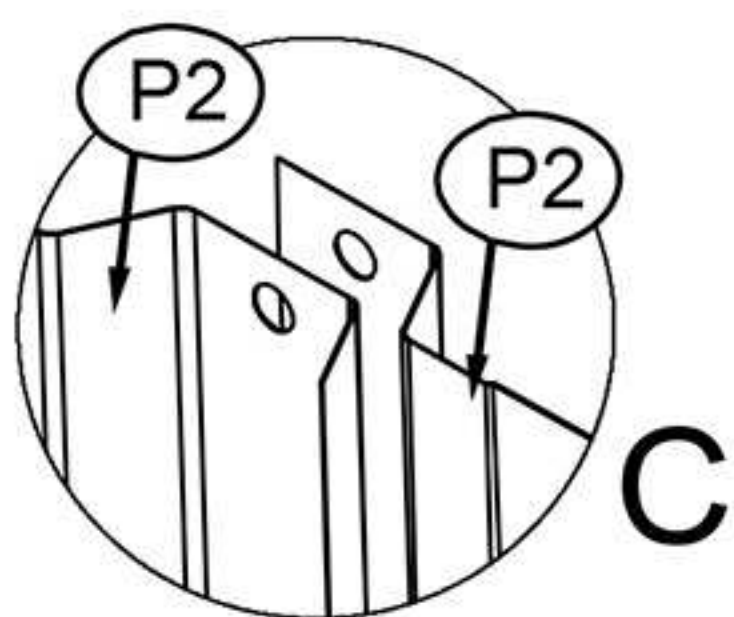





NO./NR	PART/ELEMENT	QTY./ ILOŚĆ
P2		2
F1		8
F2		2
S3		10

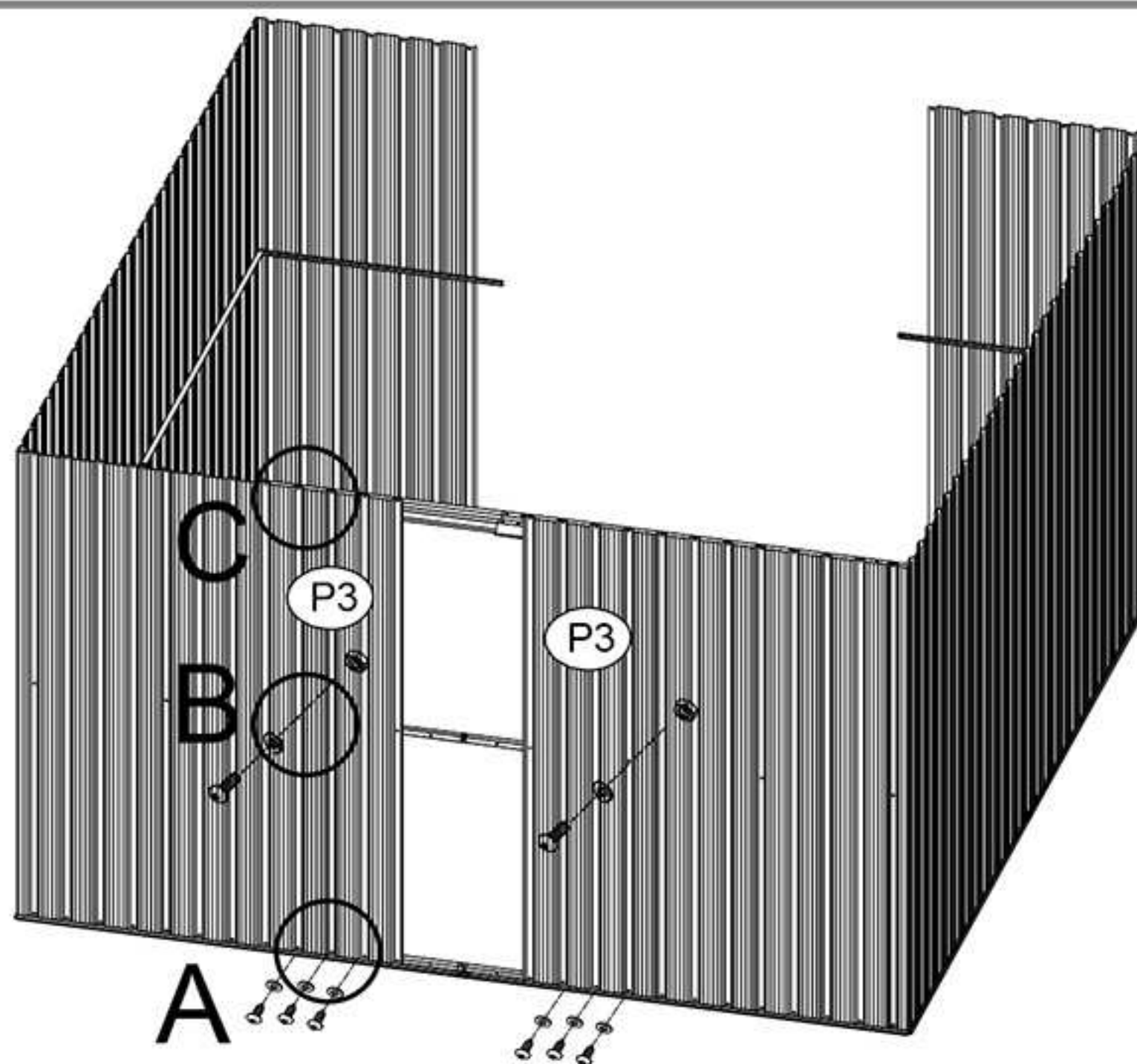
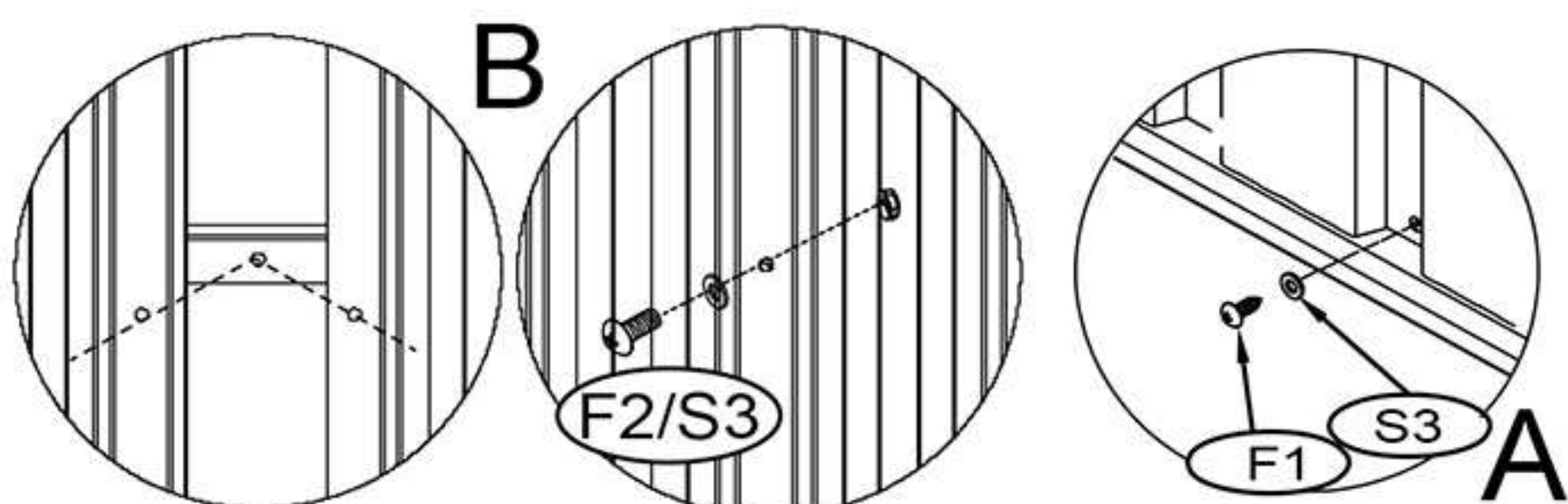
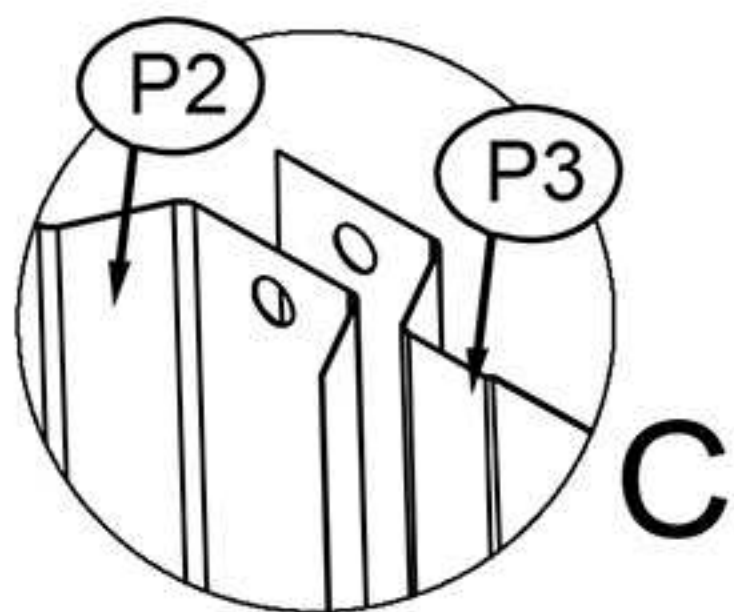

NO./NR	PART/ELEMENT	QTY./ ILOŚĆ
P3		2
F1		6
F2		2
S3		8



NO./NR	PART/ELEMENT	QTY./ ILOŚĆ
P2		1
F1		5
F2		2
S3		7

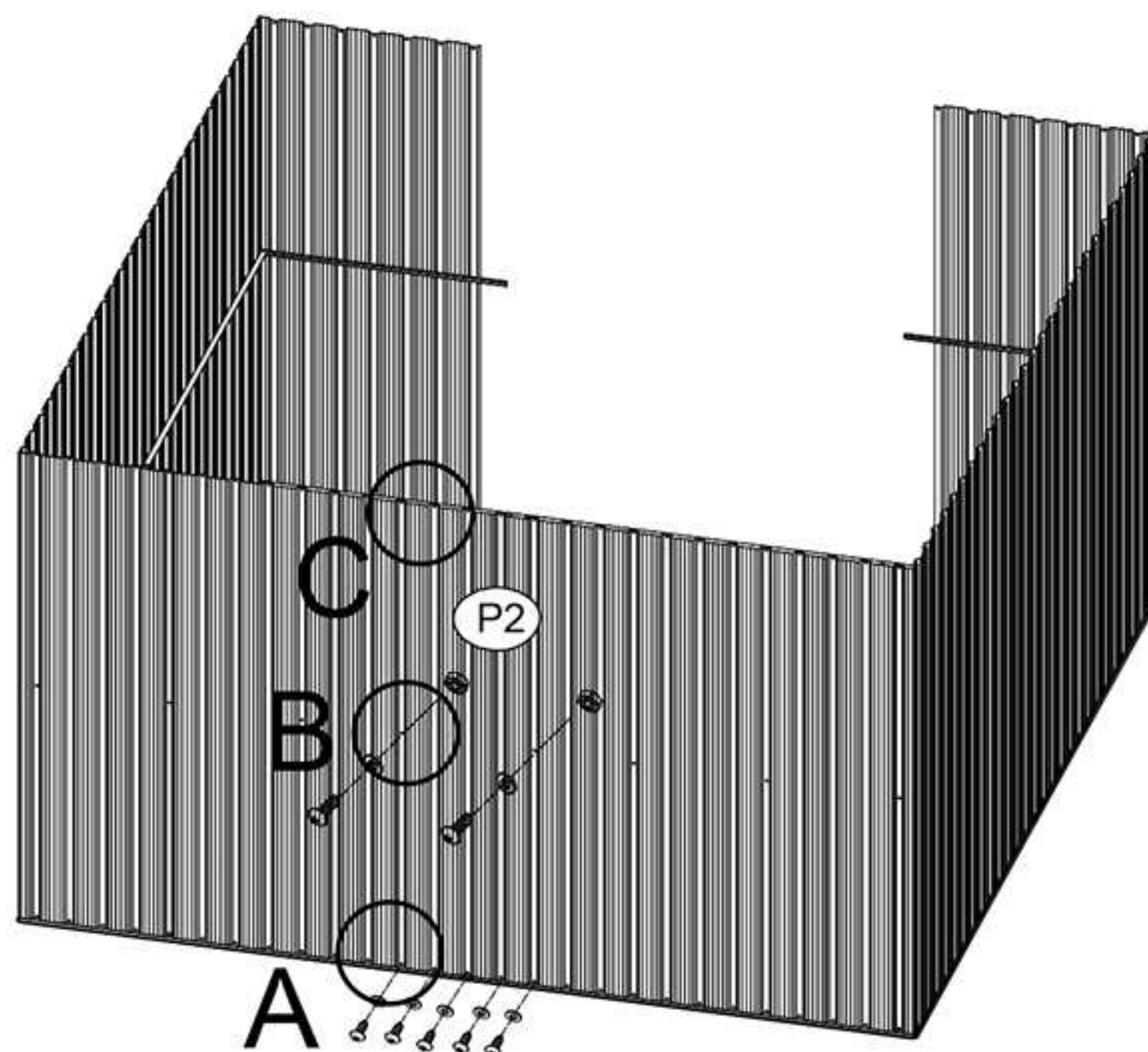
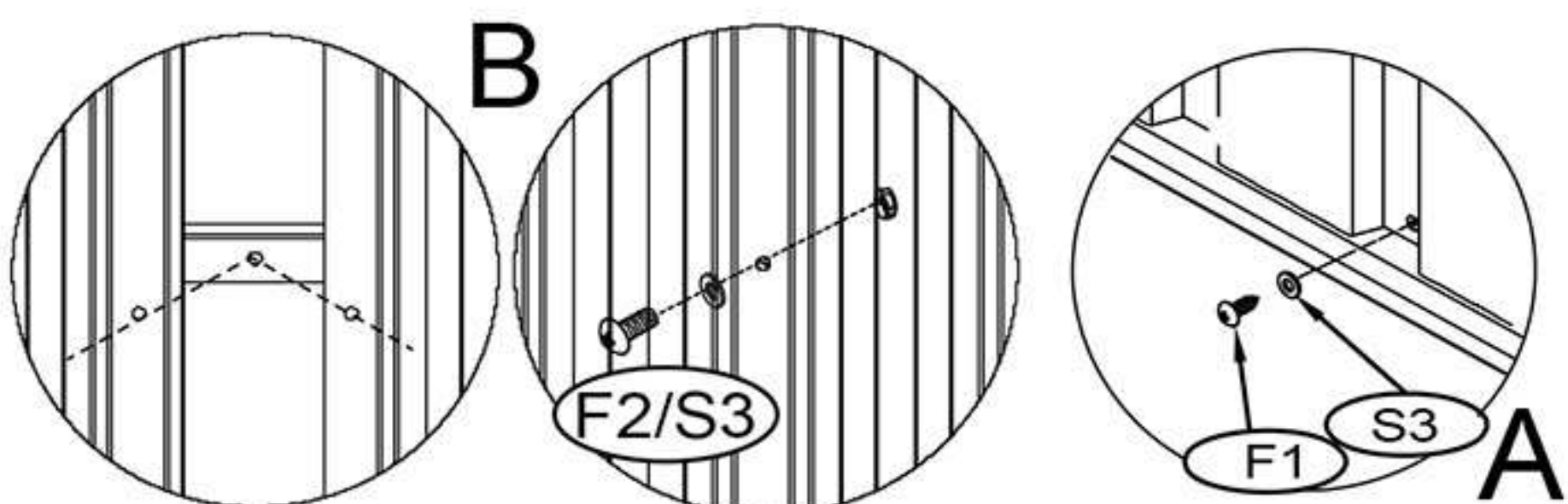
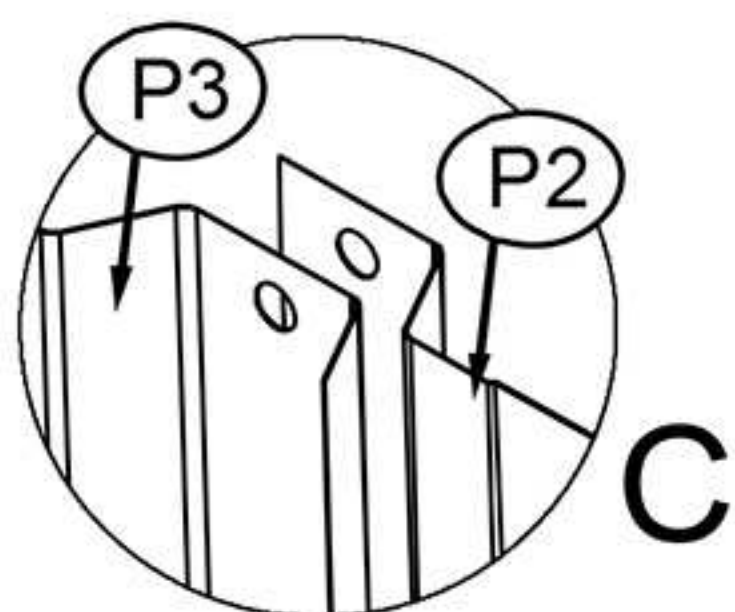

NO./NR	PART/ELEMENT	QTY./ ILOŚĆ
15		2
17		1
F1		2

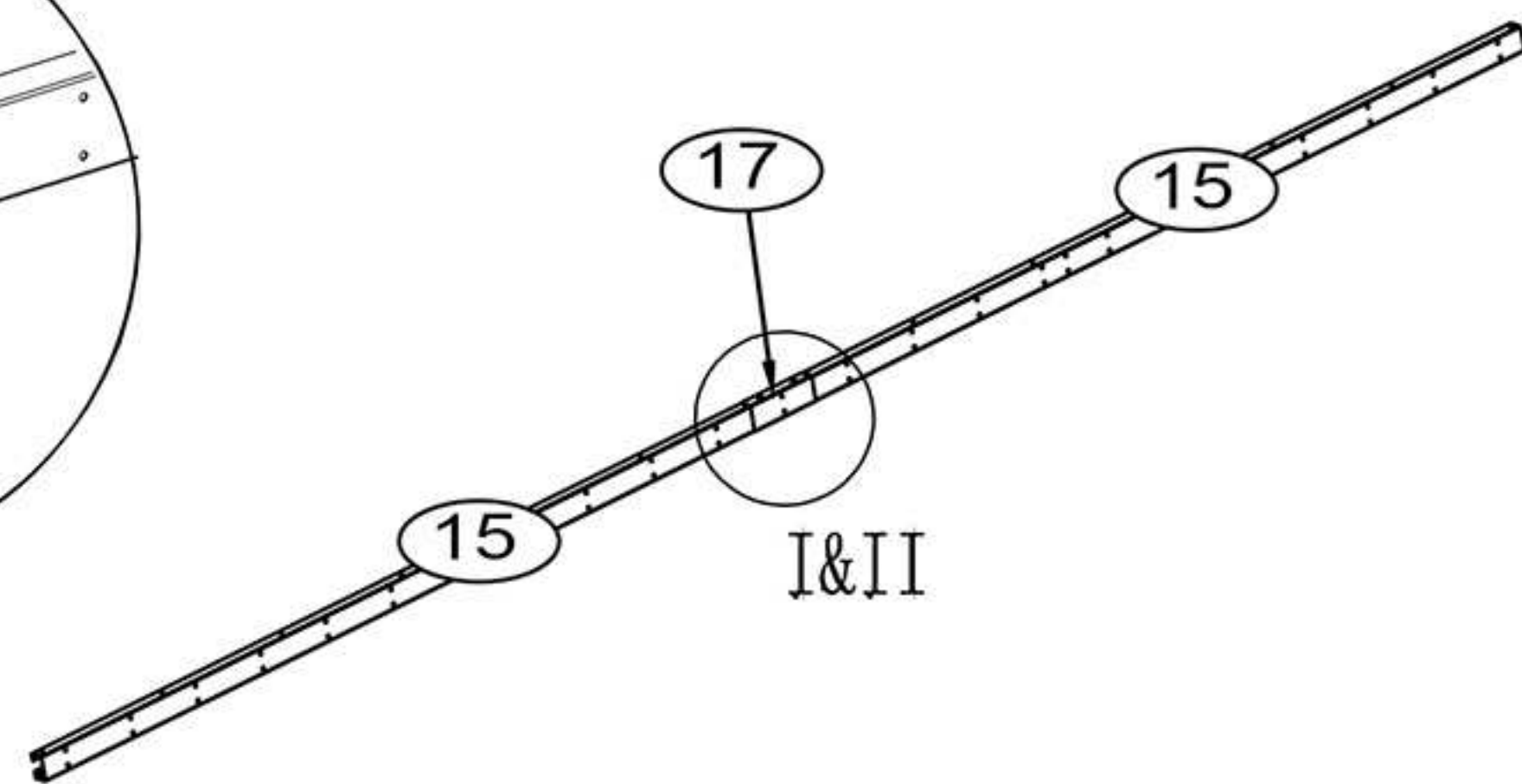
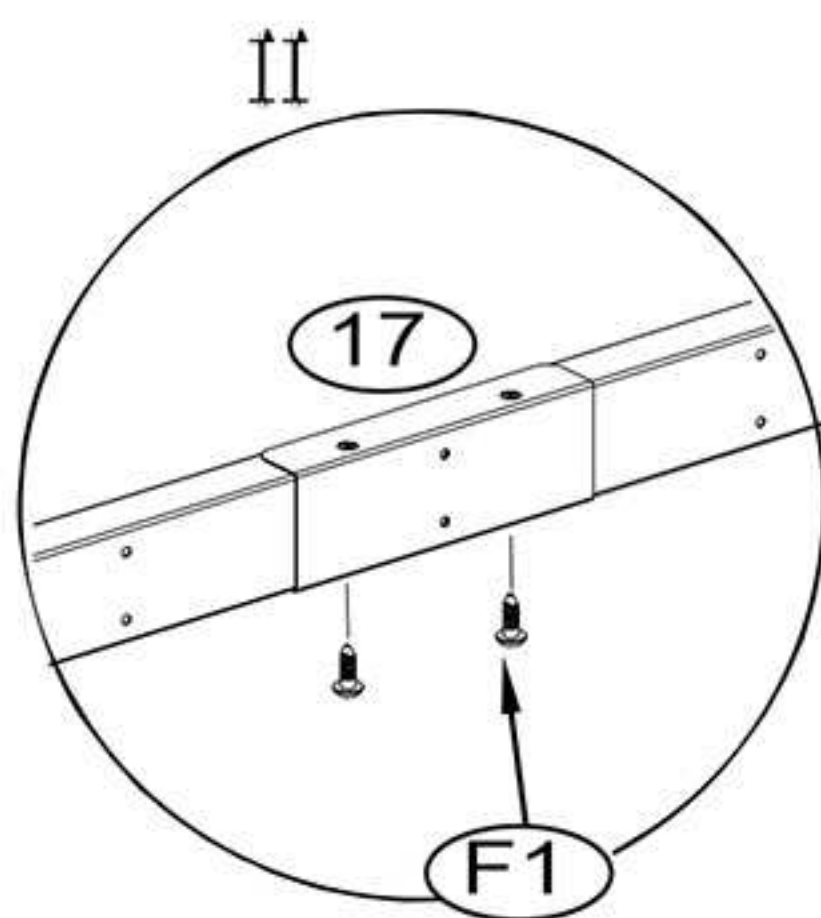
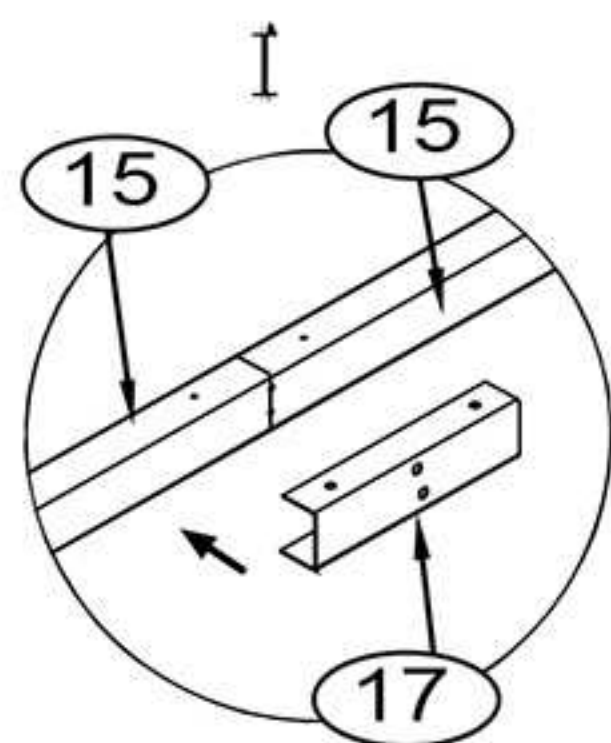

NO./NR	PART/ELEMENT	QTY./ ILOŚĆ
F1		27
S3		27

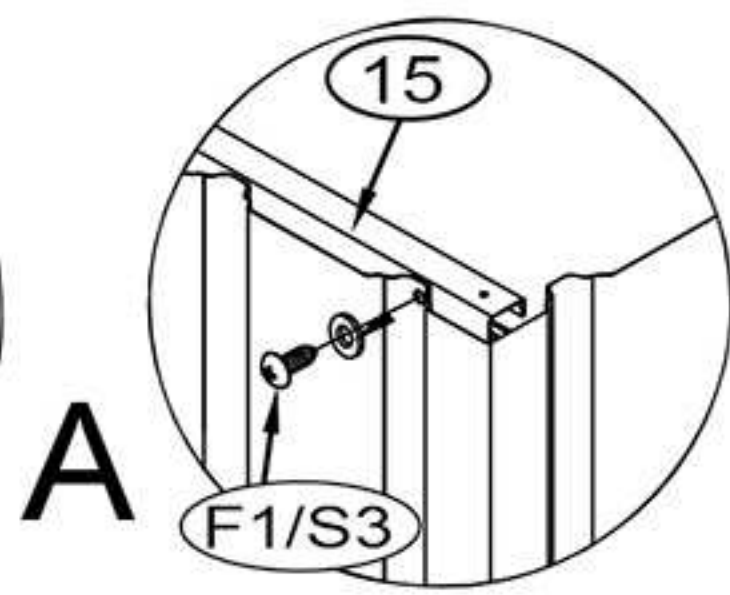
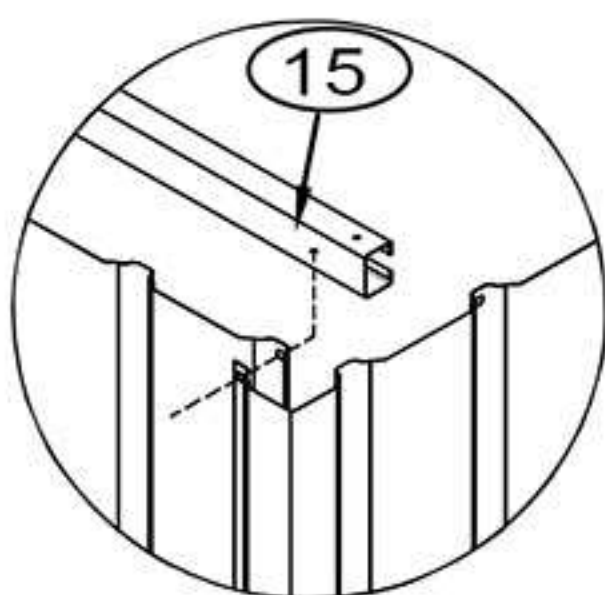
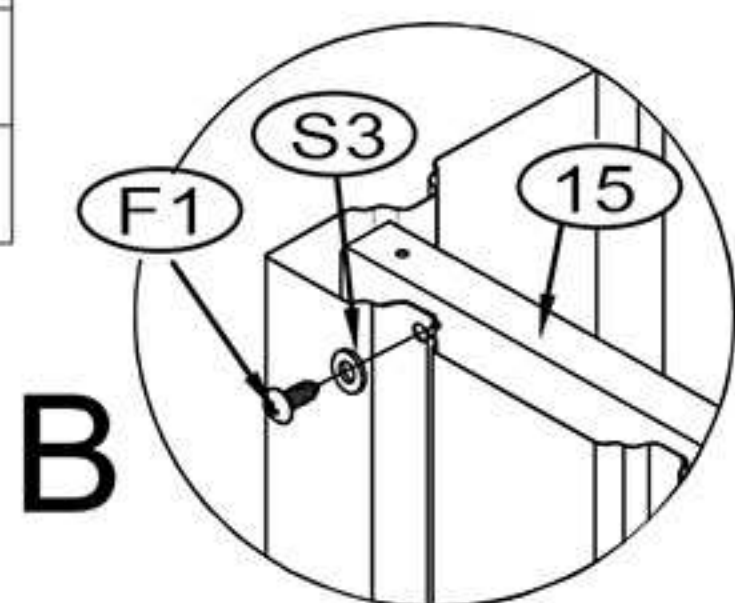

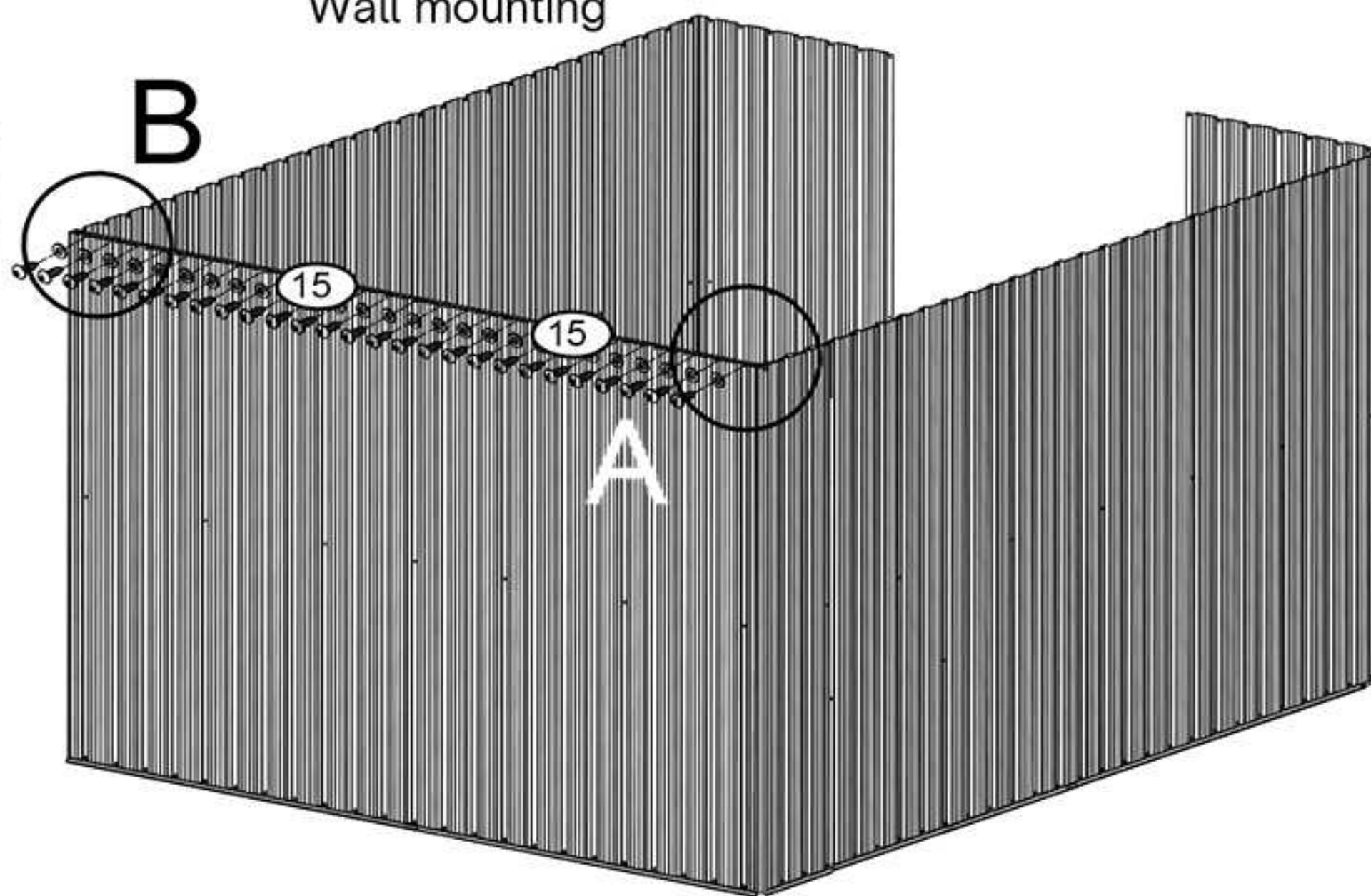

Montaż ścienny  
Wall mounting



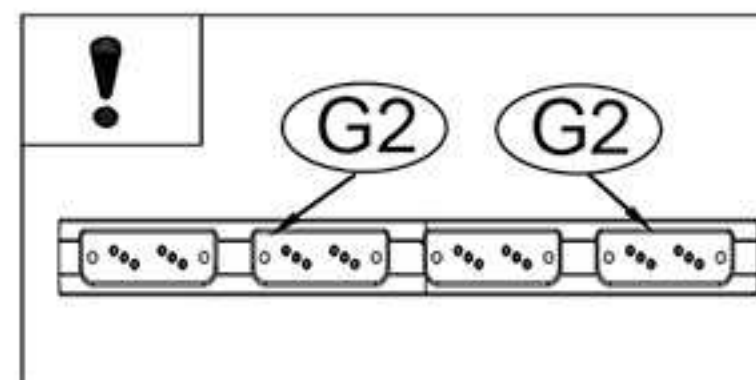
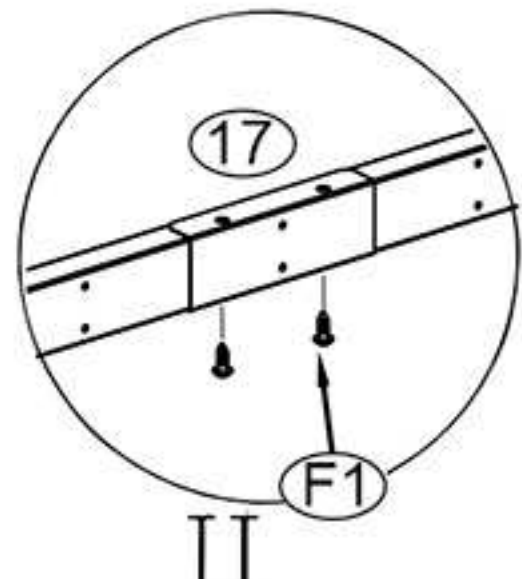
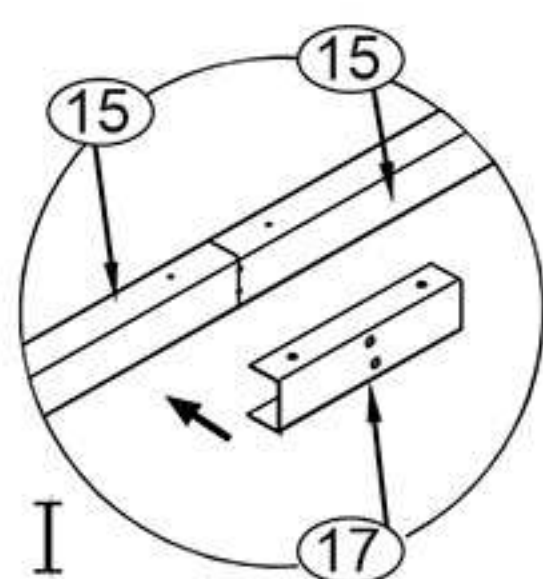
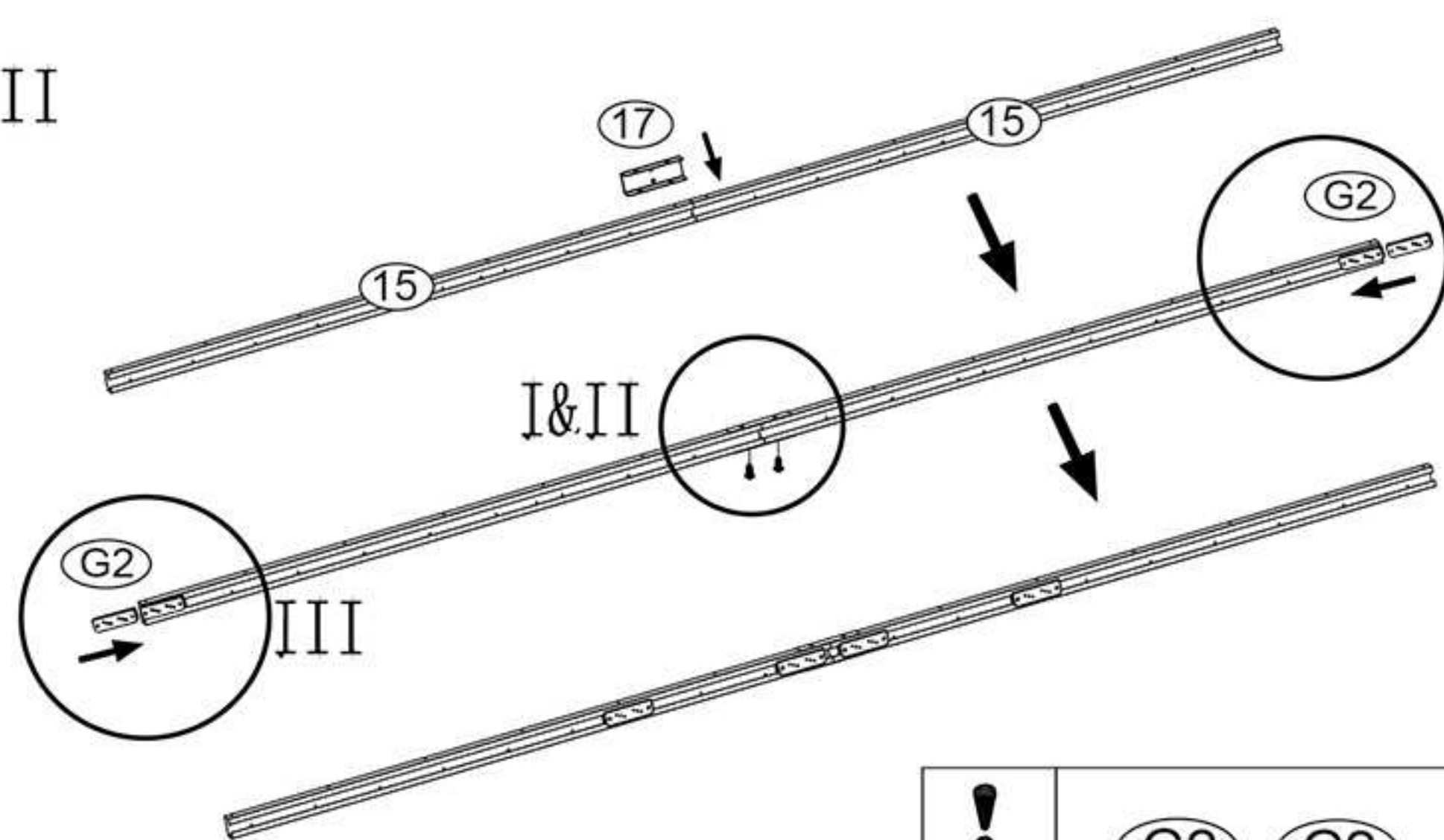
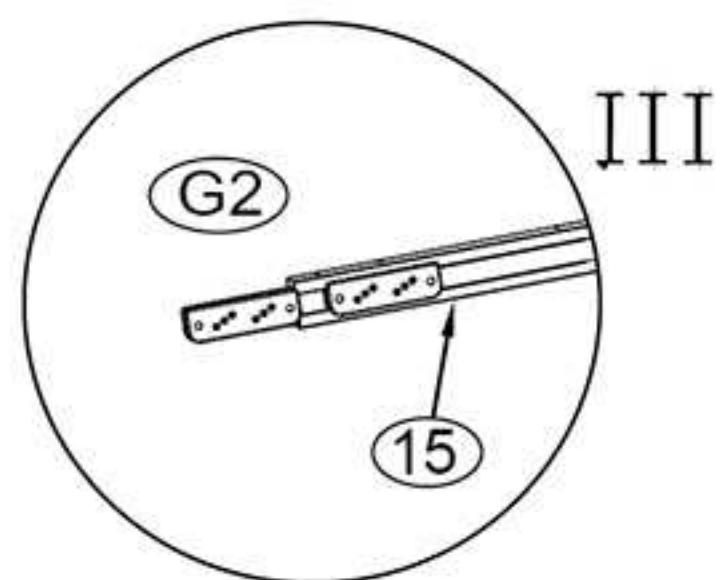



NO./NR	PART/ELEMENT	QTY./ ILOŚĆ
15		2
17		1
F1		2
G2		4

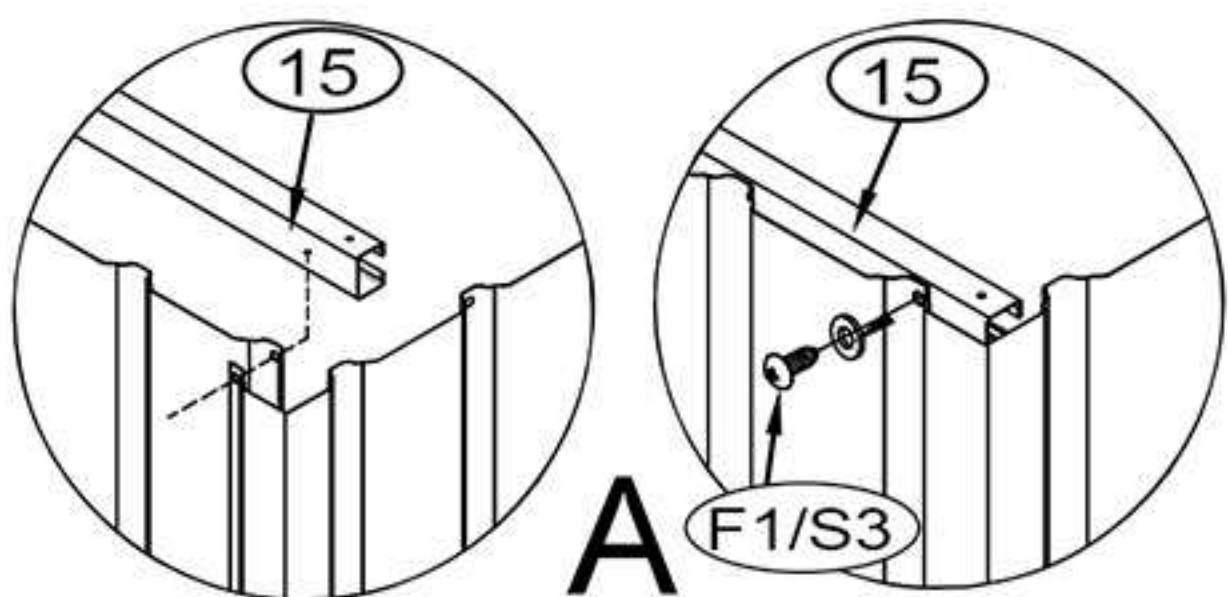
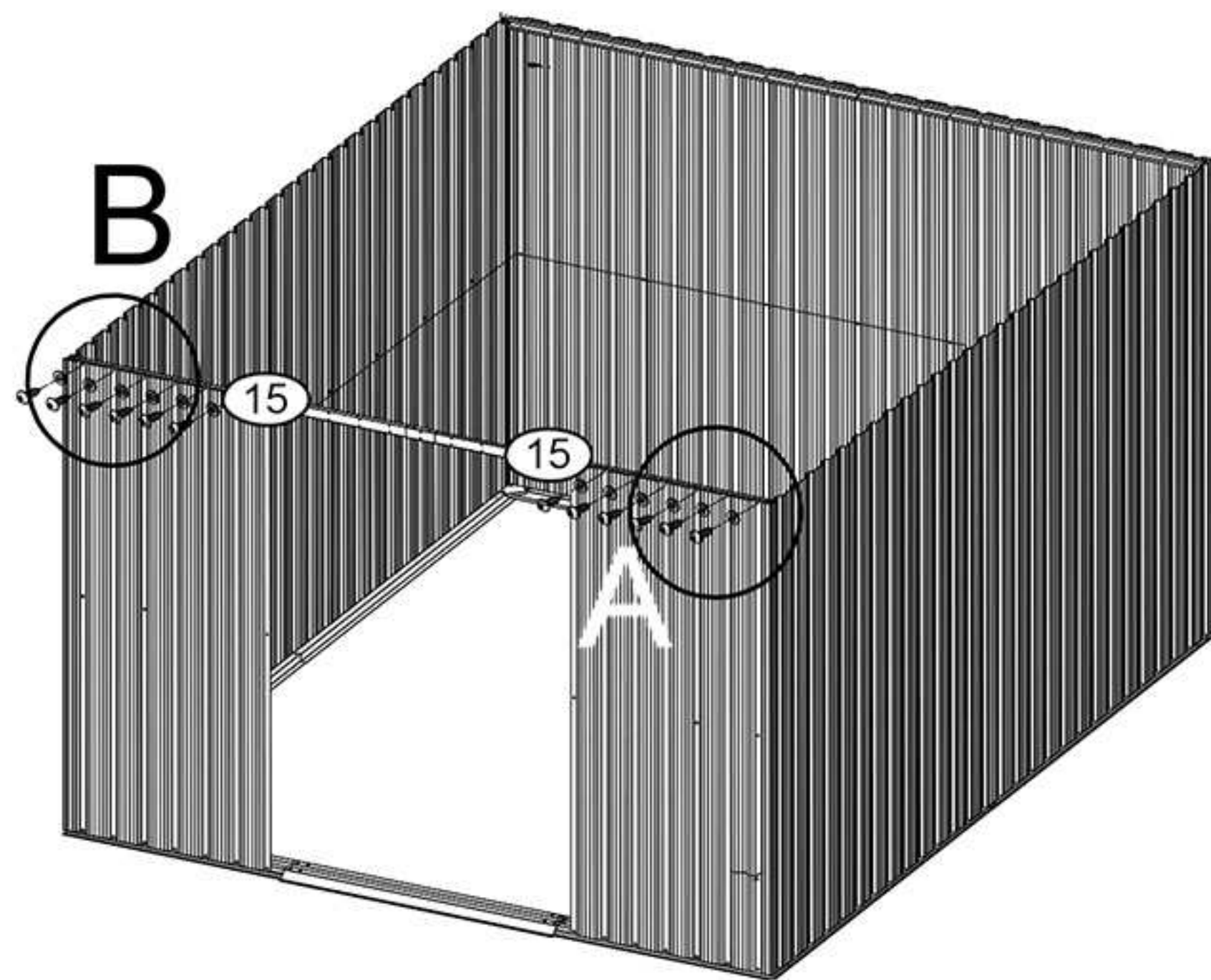
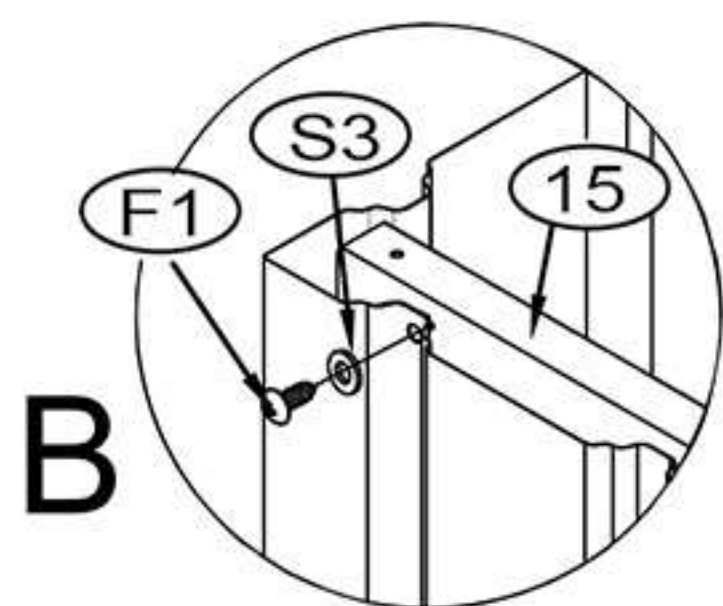



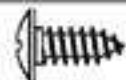

NO./NR	PART/ELEMENT	QTY./ ILOŚĆ
F1		12
S3		12

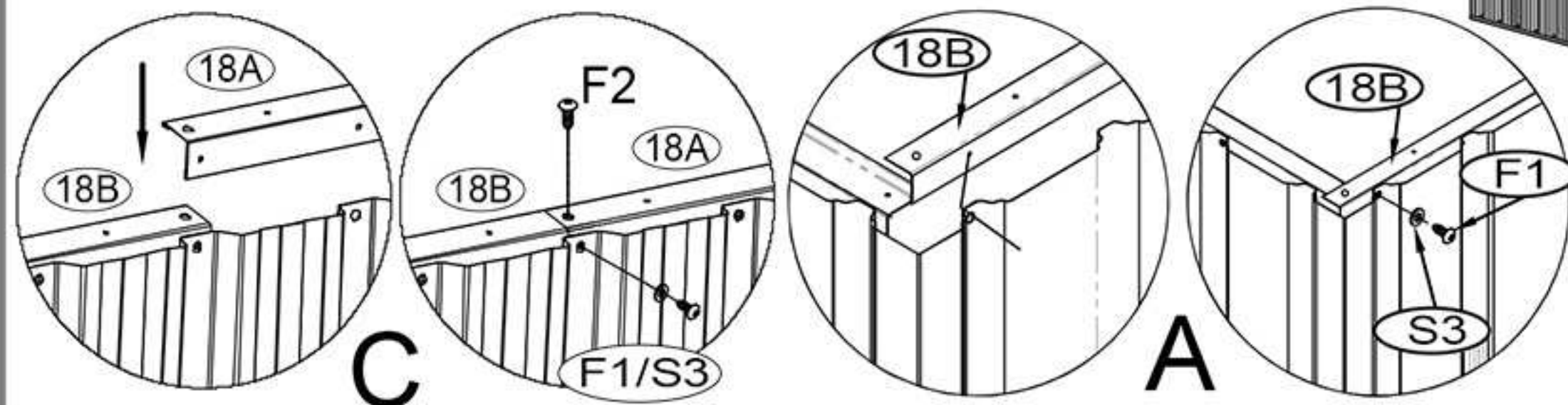
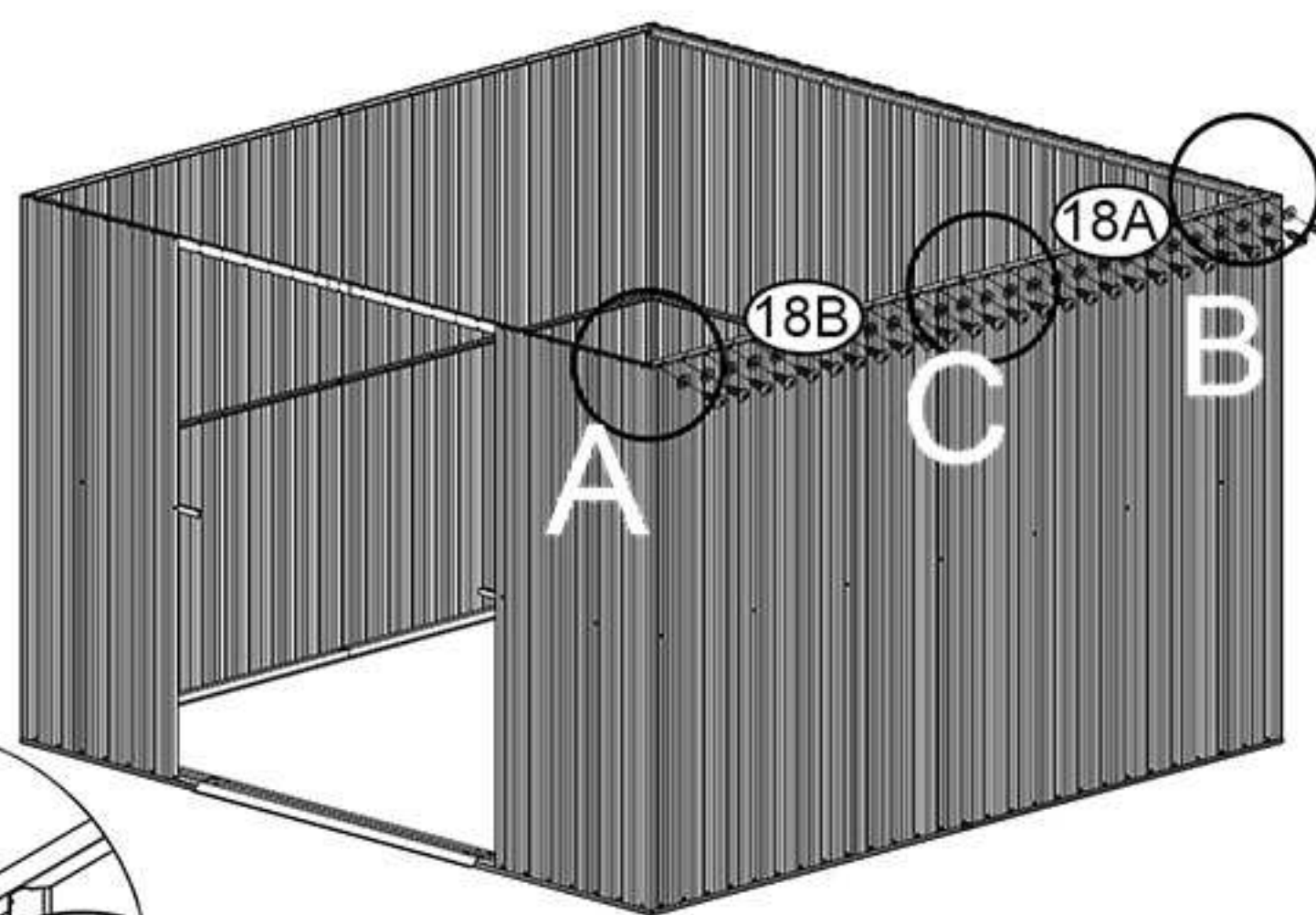
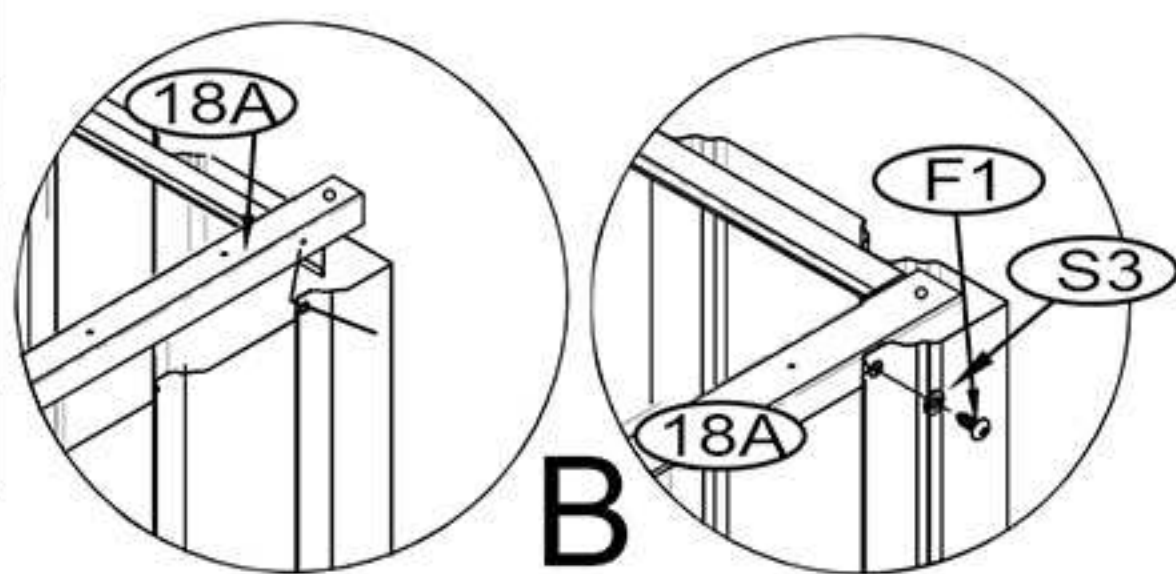

NO./NR	PART/ELEMENT	QTY./ ILOŚĆ
18A		1
18B		1
F1		27
F2		1
S3		27



NO./NR	PART/ELEMENT	QTY./ ILOŚĆ
18A		1
18B		1
F1		27
F2		1
S3		27

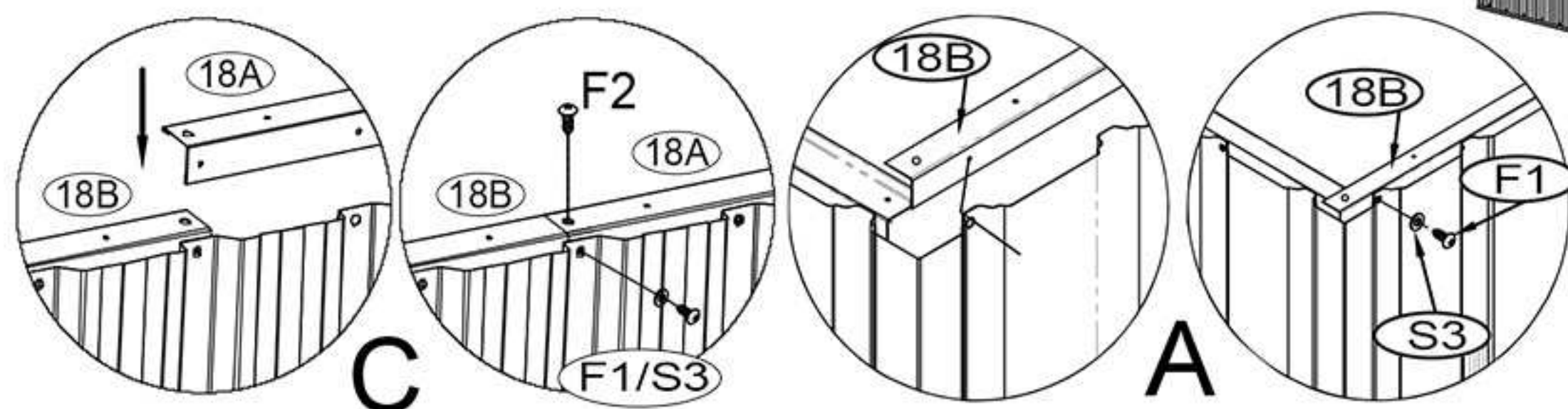
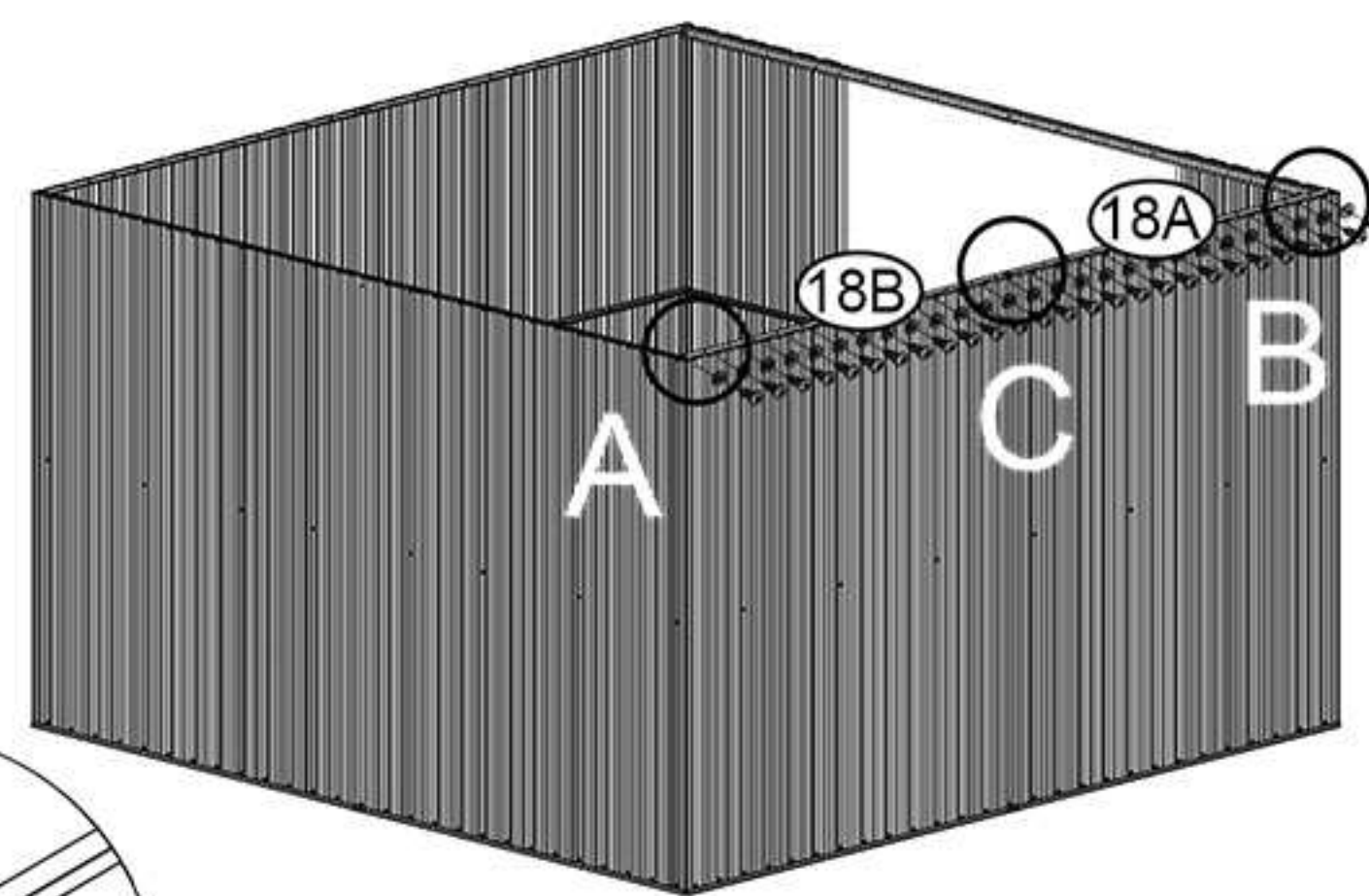
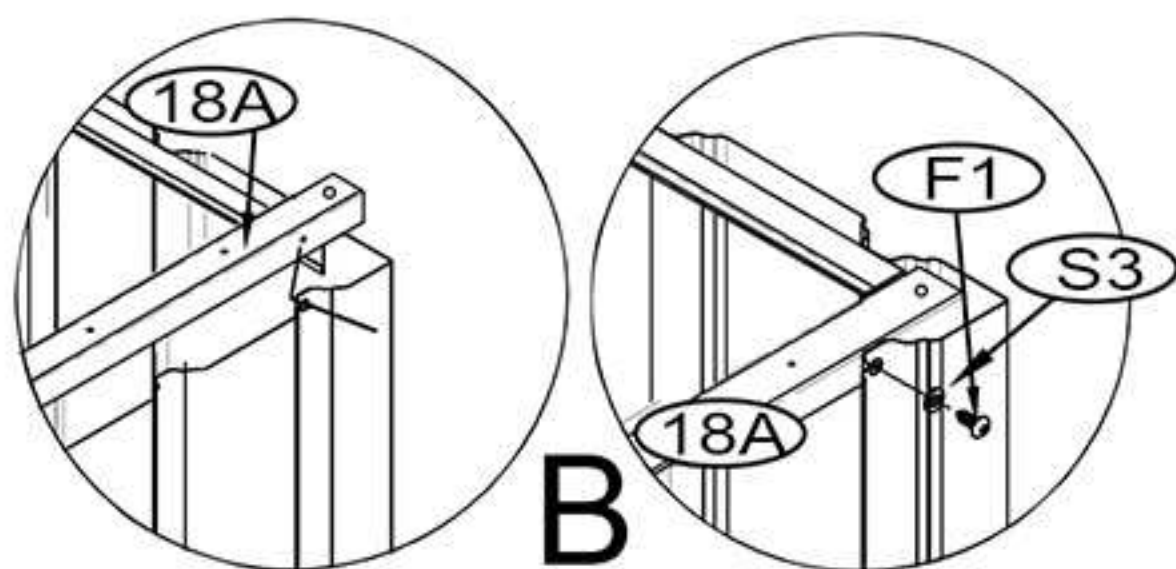

NO./NR	PART/ELEMENT	QTY./ ILOŚĆ
22A		1
22B		1
F1		14
F2		2
S3		8

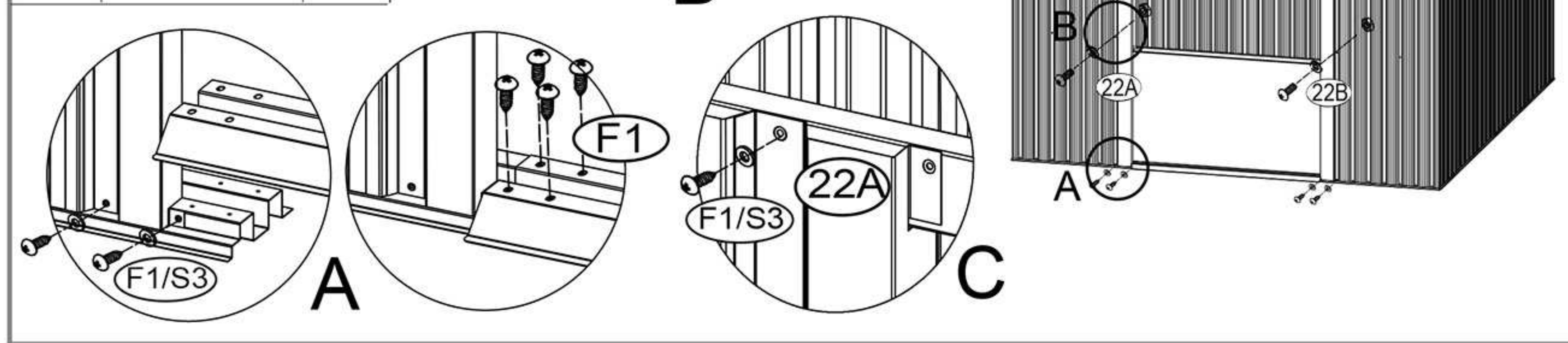

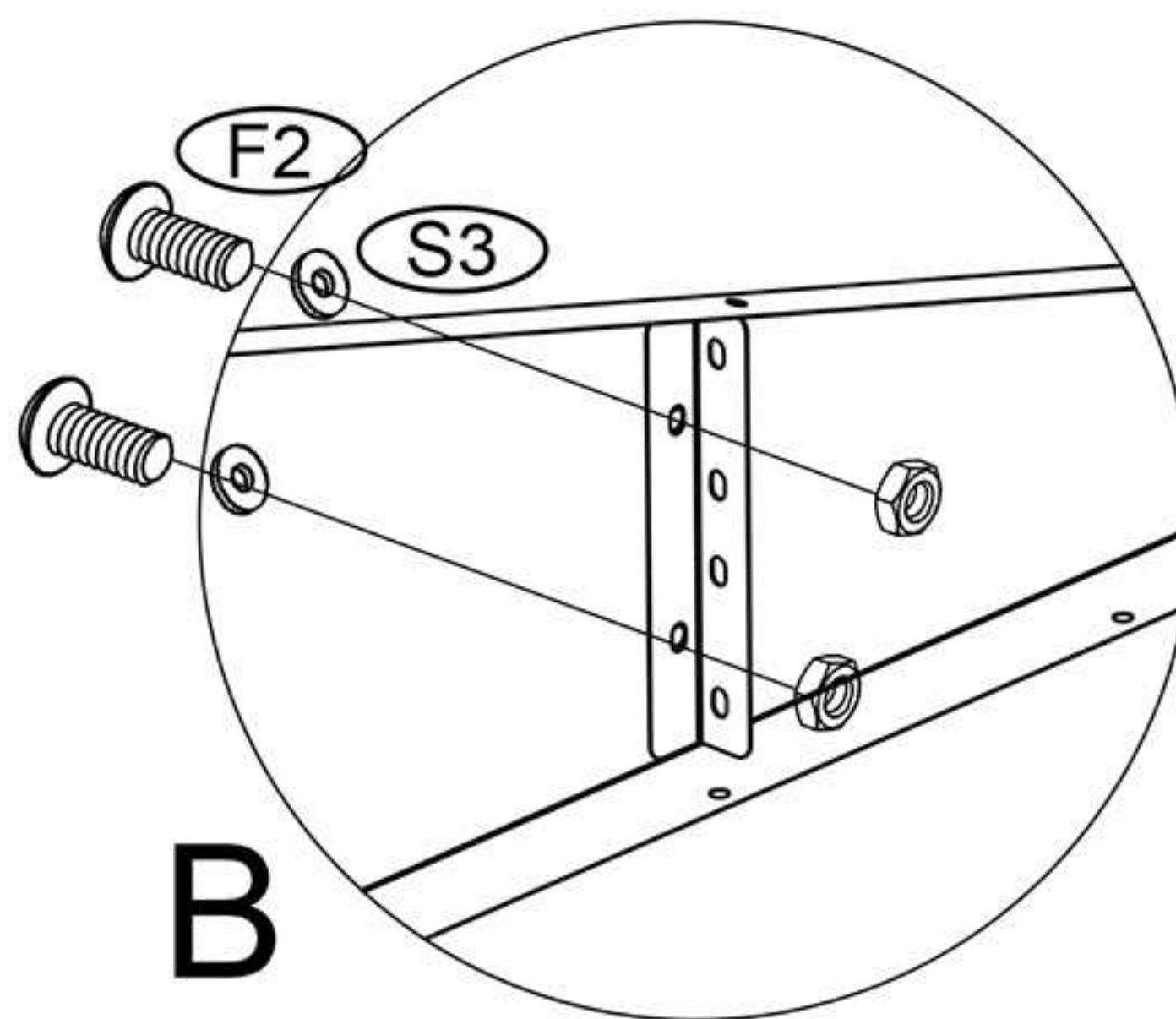
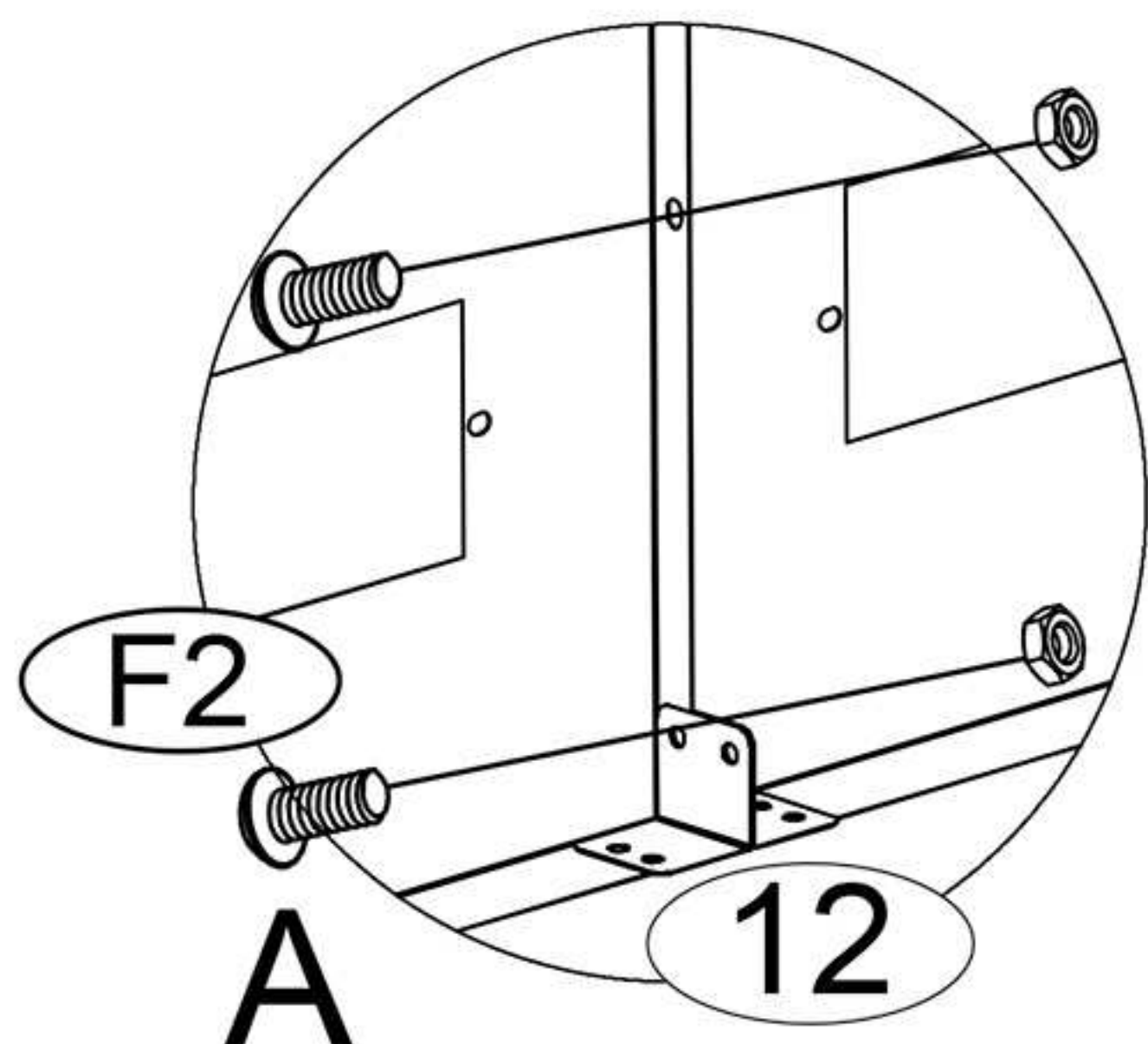
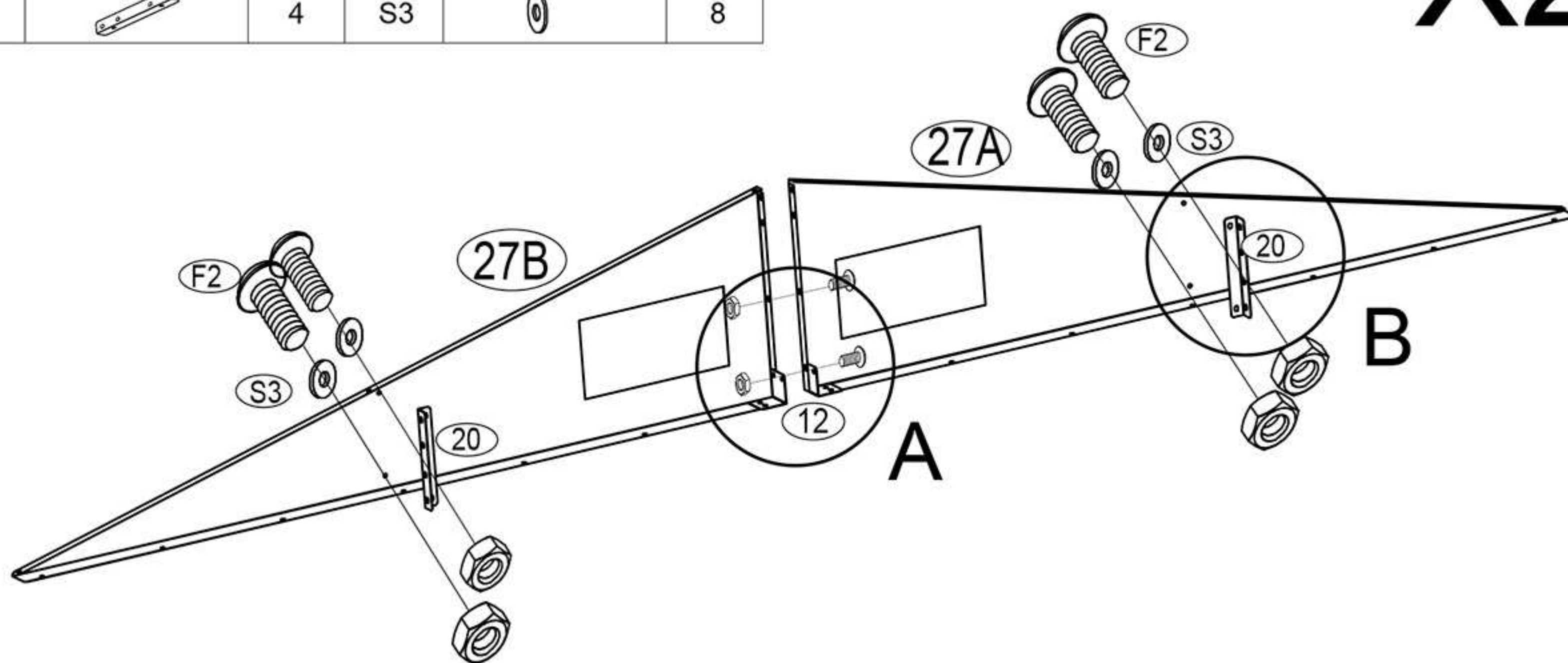

NO./NR	PART/ELEMENT	QTY./ ILOŚĆ	NO./NR	PART/ELEMENT	QTY./ ILOŚĆ
27A		2	12		4
27B		2	F2		12
20		4	S3		8

**X2**







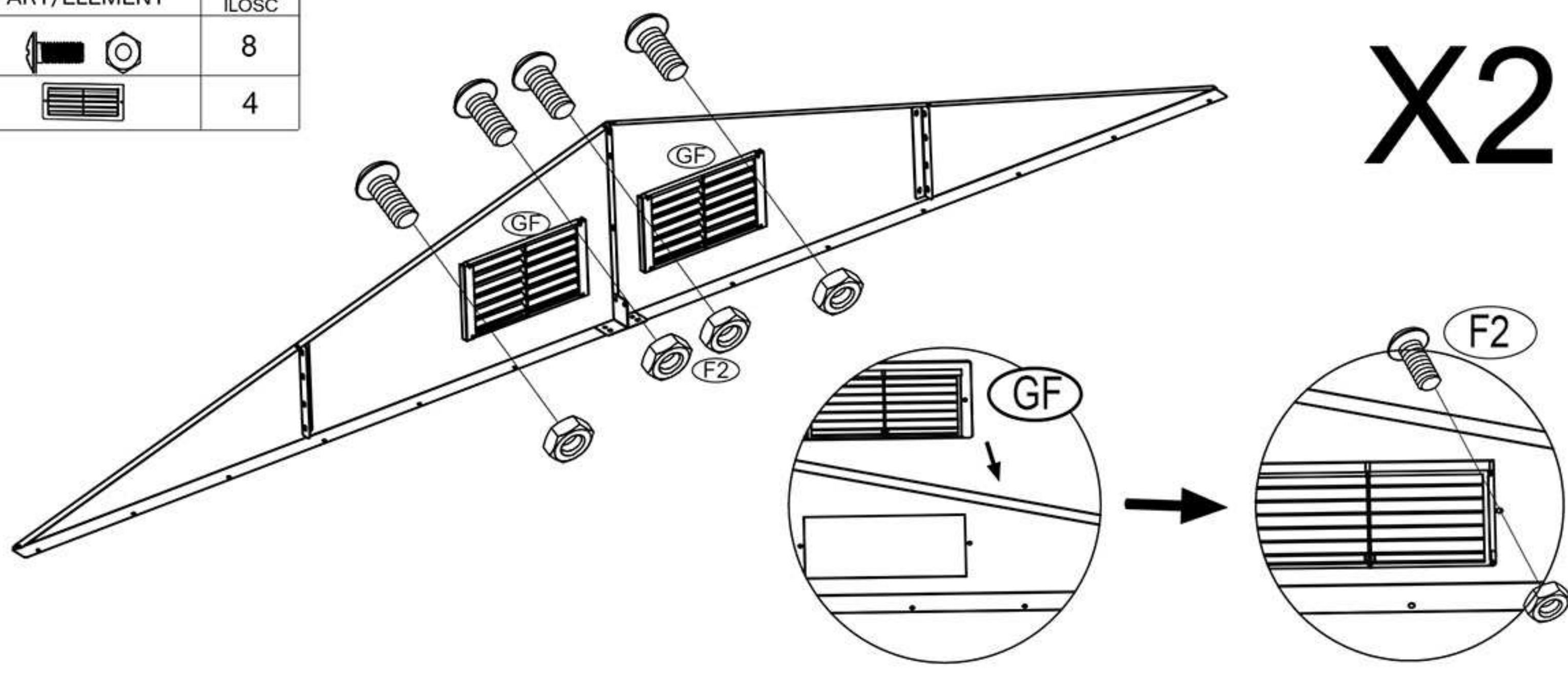

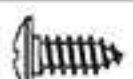
NO./NR	PART/ELEMENT	QTY./ ILOŚĆ
F2		8
GF		4

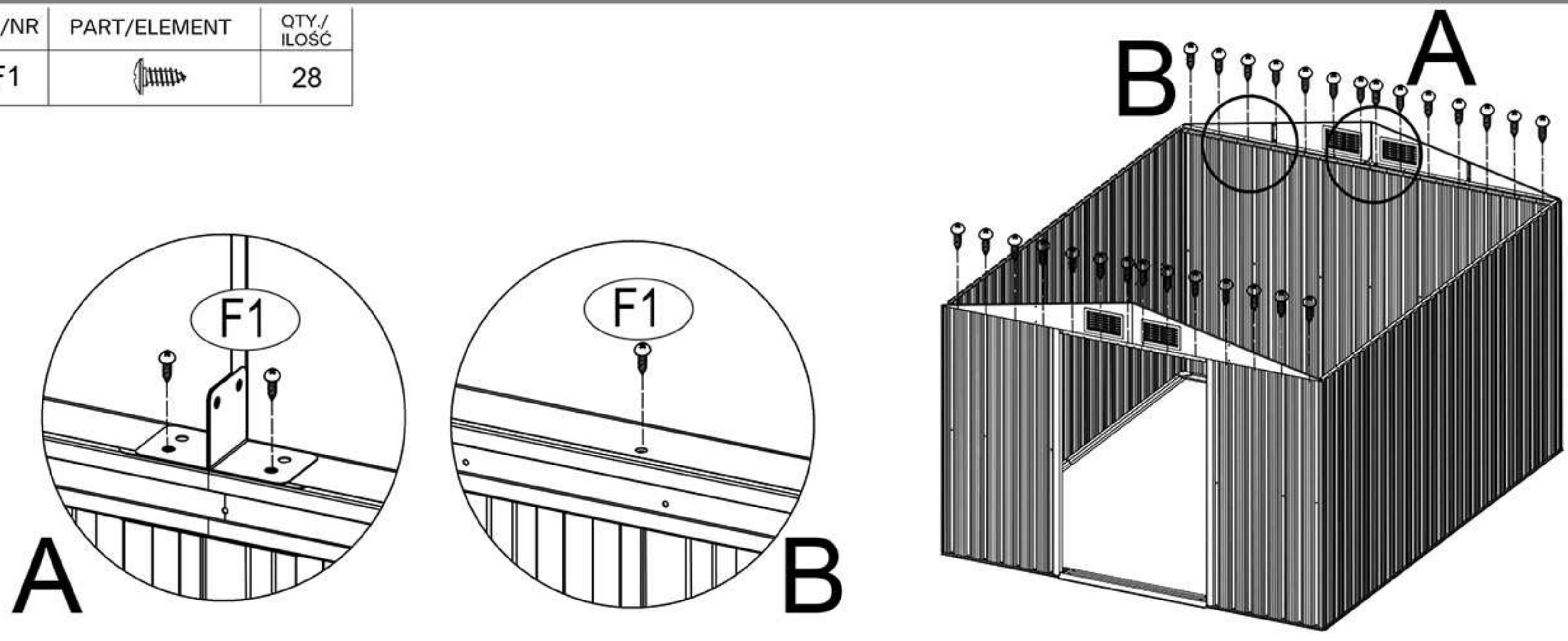

NO./NR	PART/ELEMENT	QTY./ ILOŚĆ
F1		28





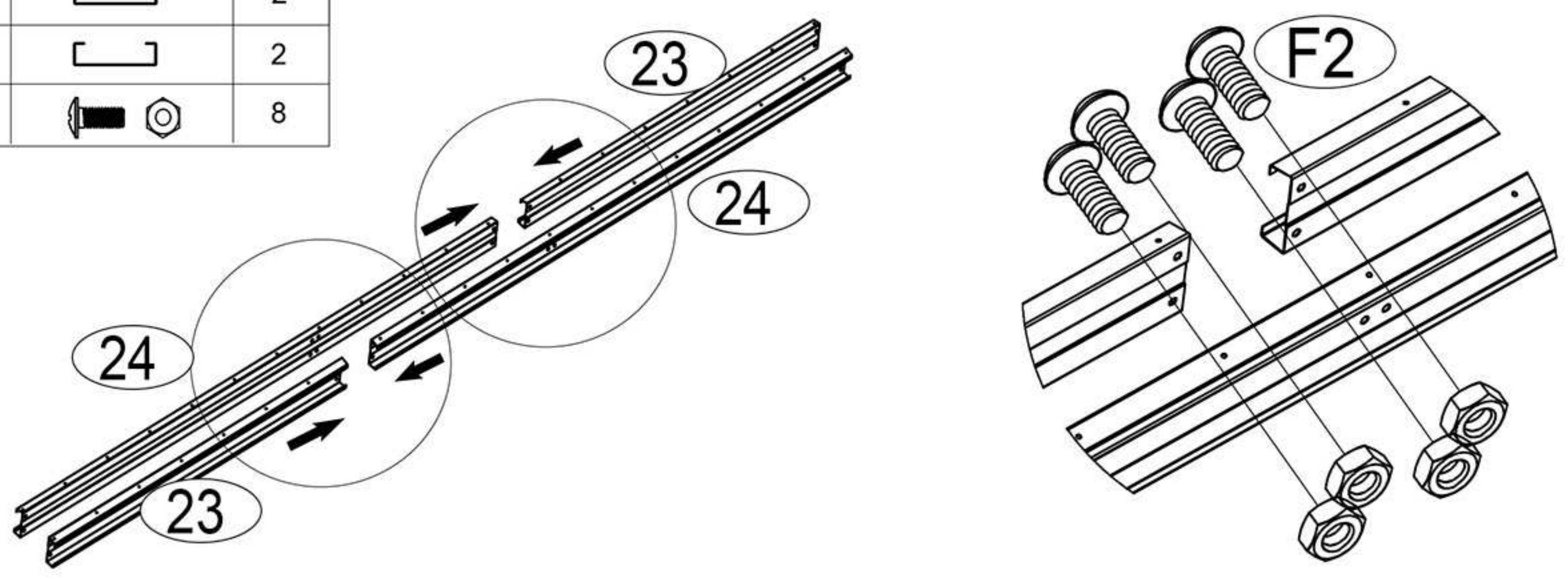

NO./NR	PART/ELEMENT	QTY./ ILOŚĆ
23		2
24		2
F2		8

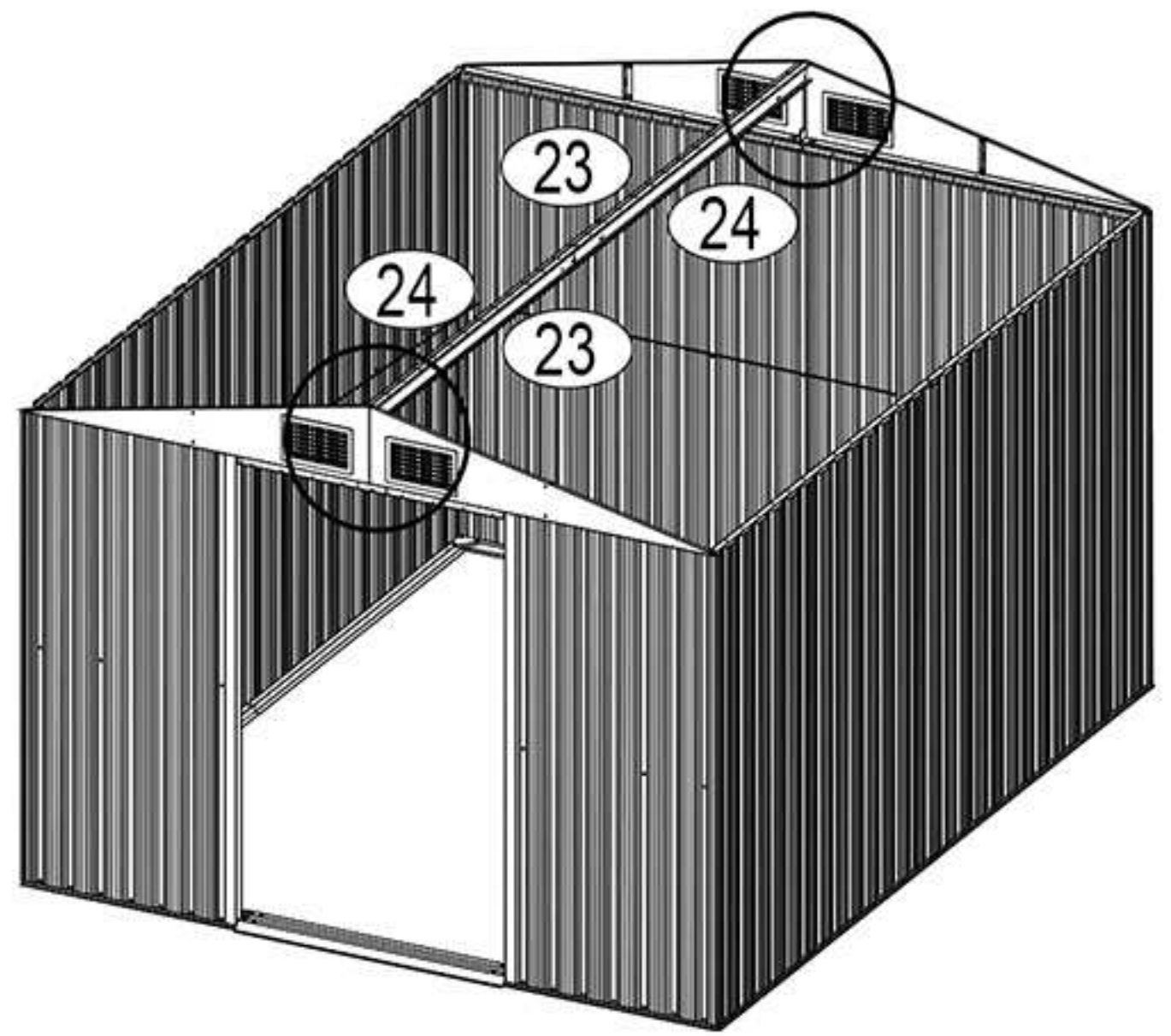
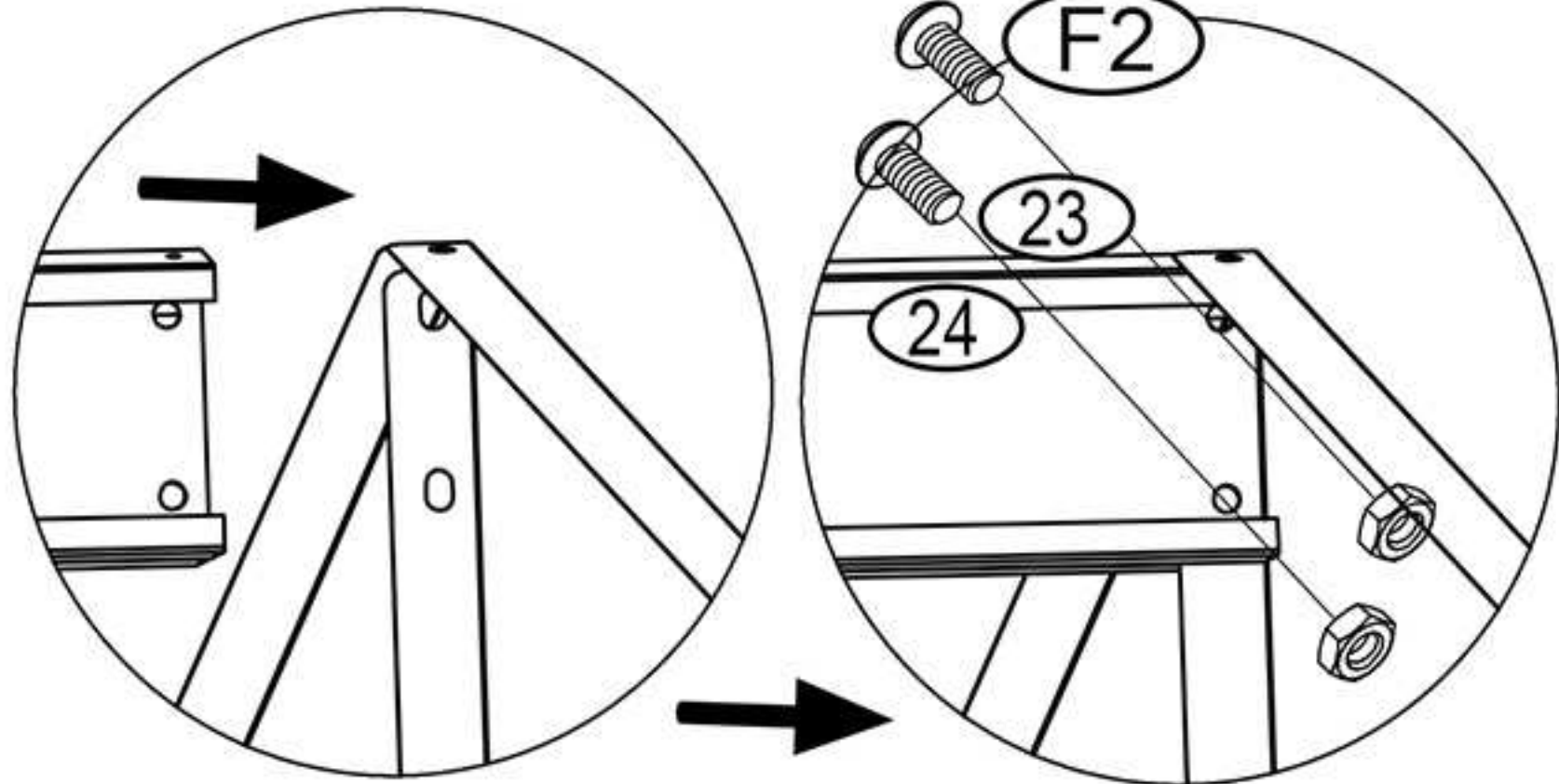

NO./NR	PART/ELEMENT	QTY./ILOŚĆ
F2		4

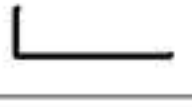

NO./NR	PART/ELEMENT	QTY./ILOŚĆ
23		2
24		2
25		2
F2		16

**X2**

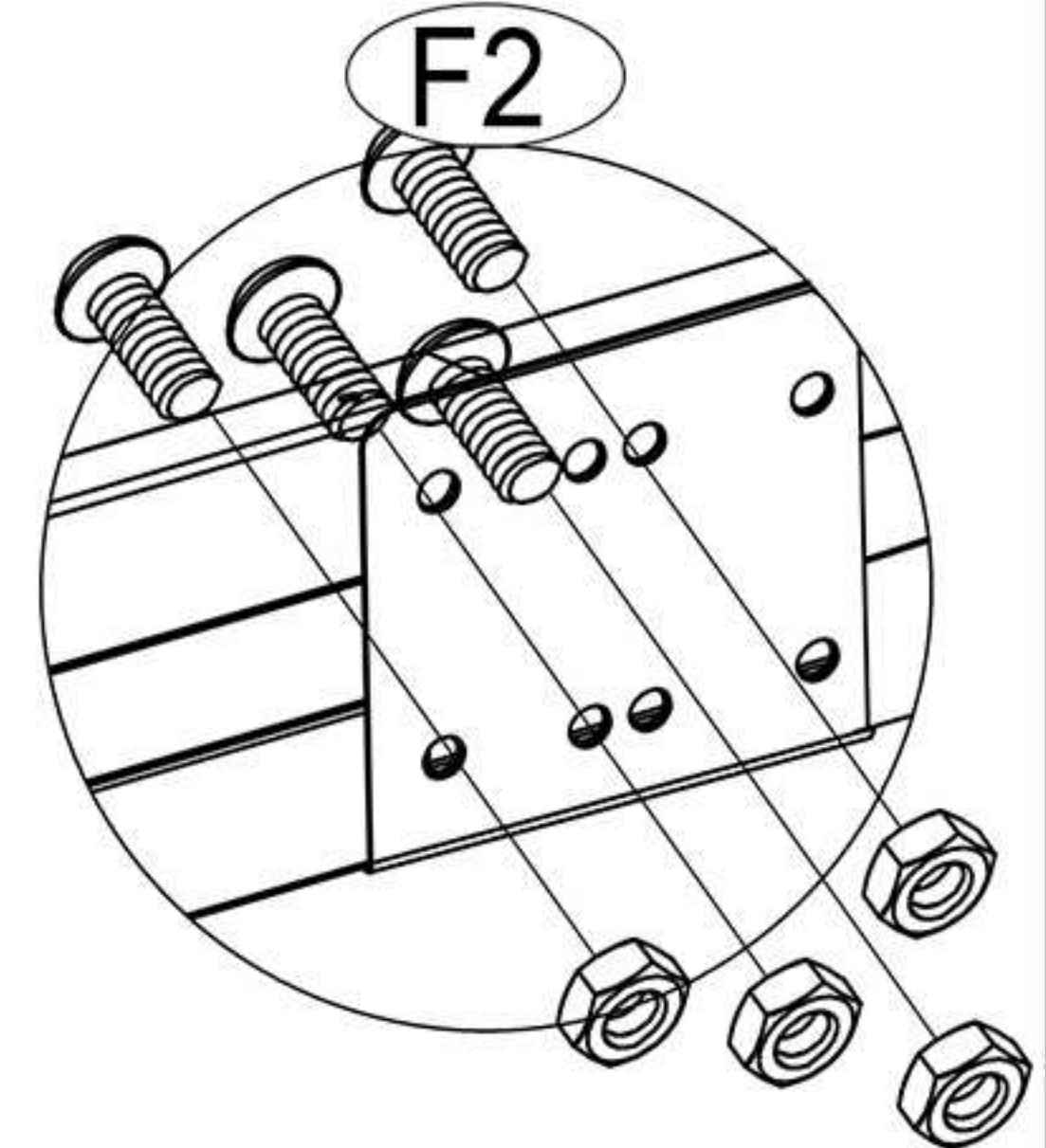
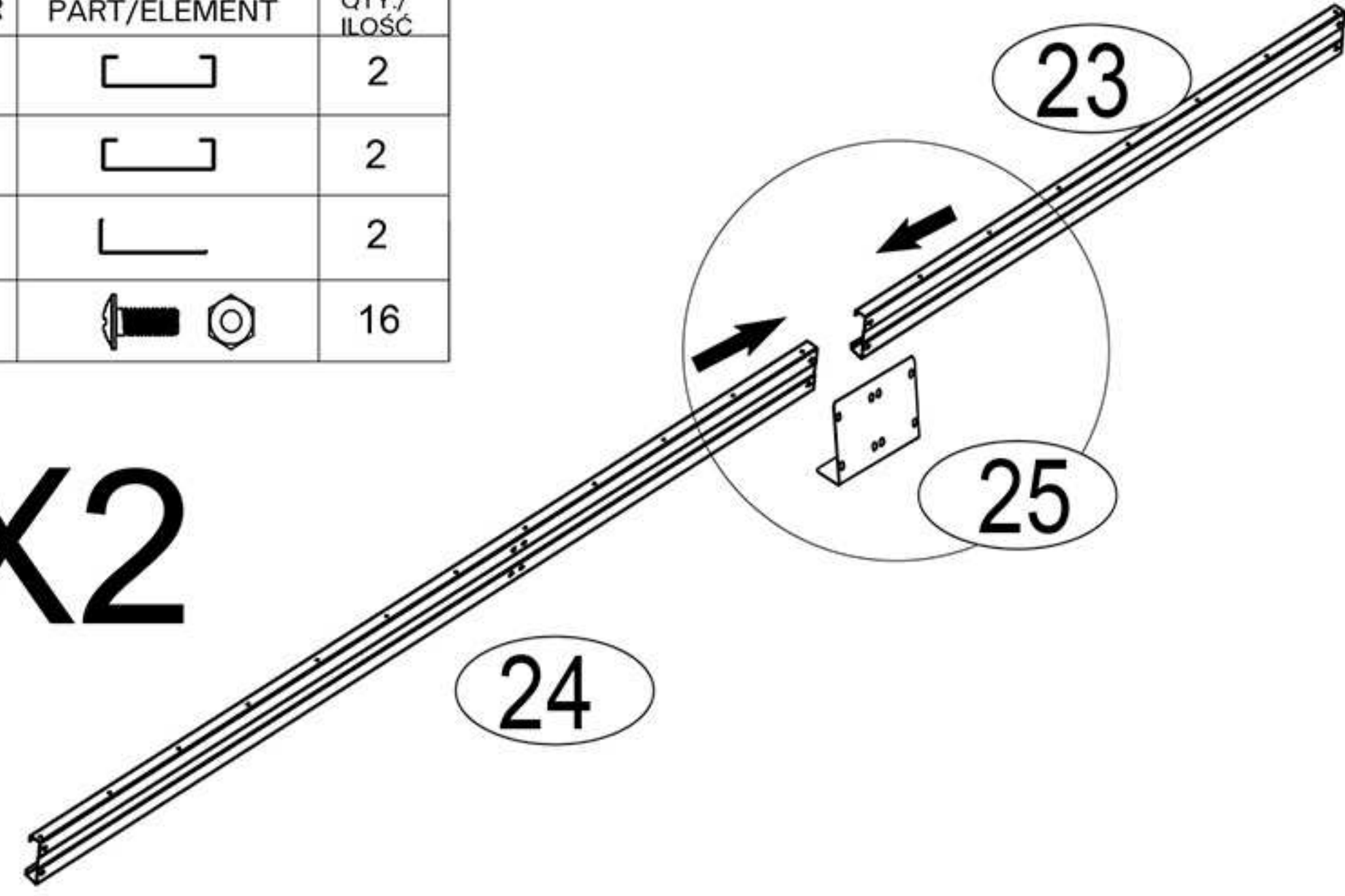

NO./NR	PART/ELEMENT	QTY./ILOŚĆ
F2		8

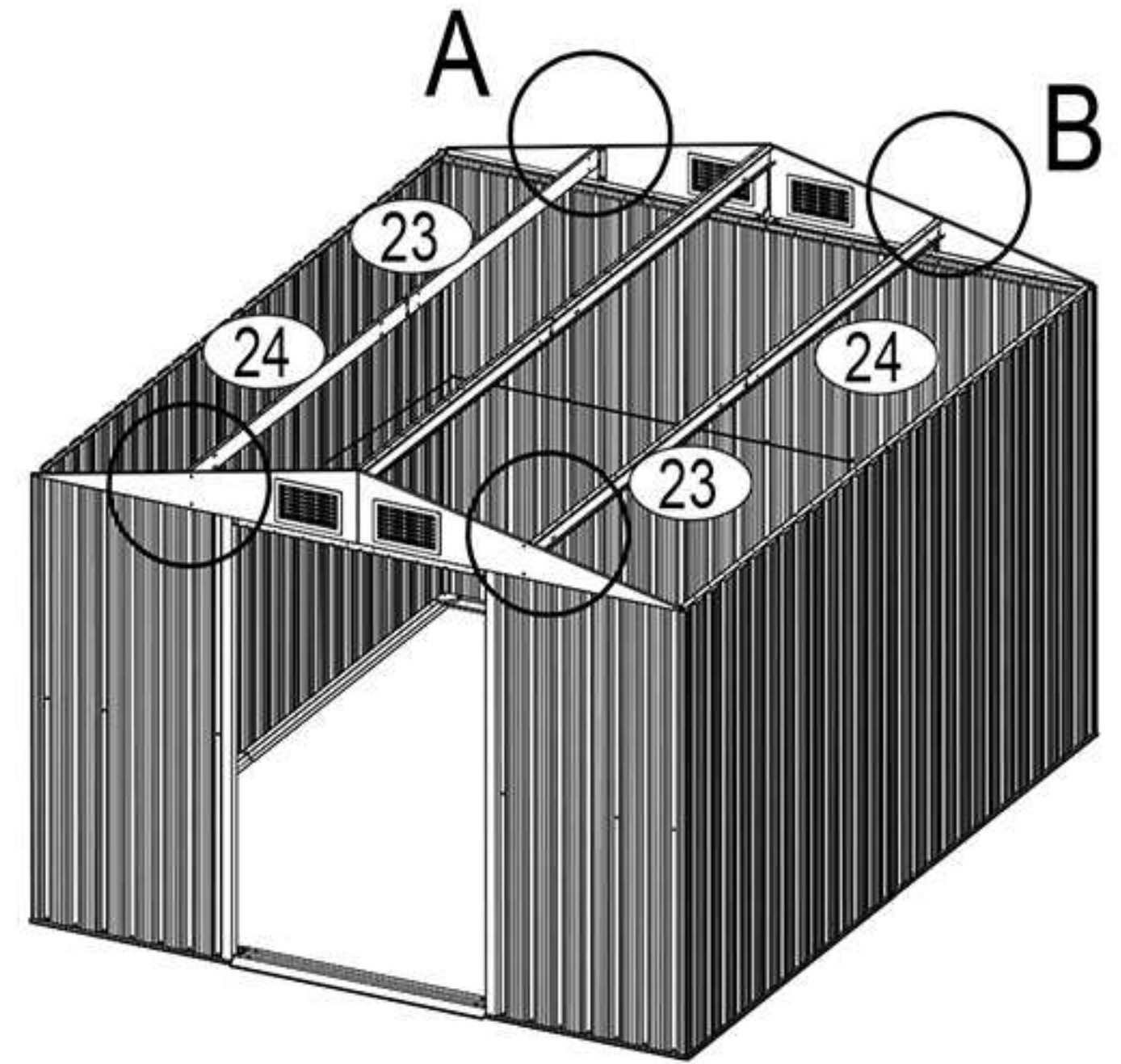
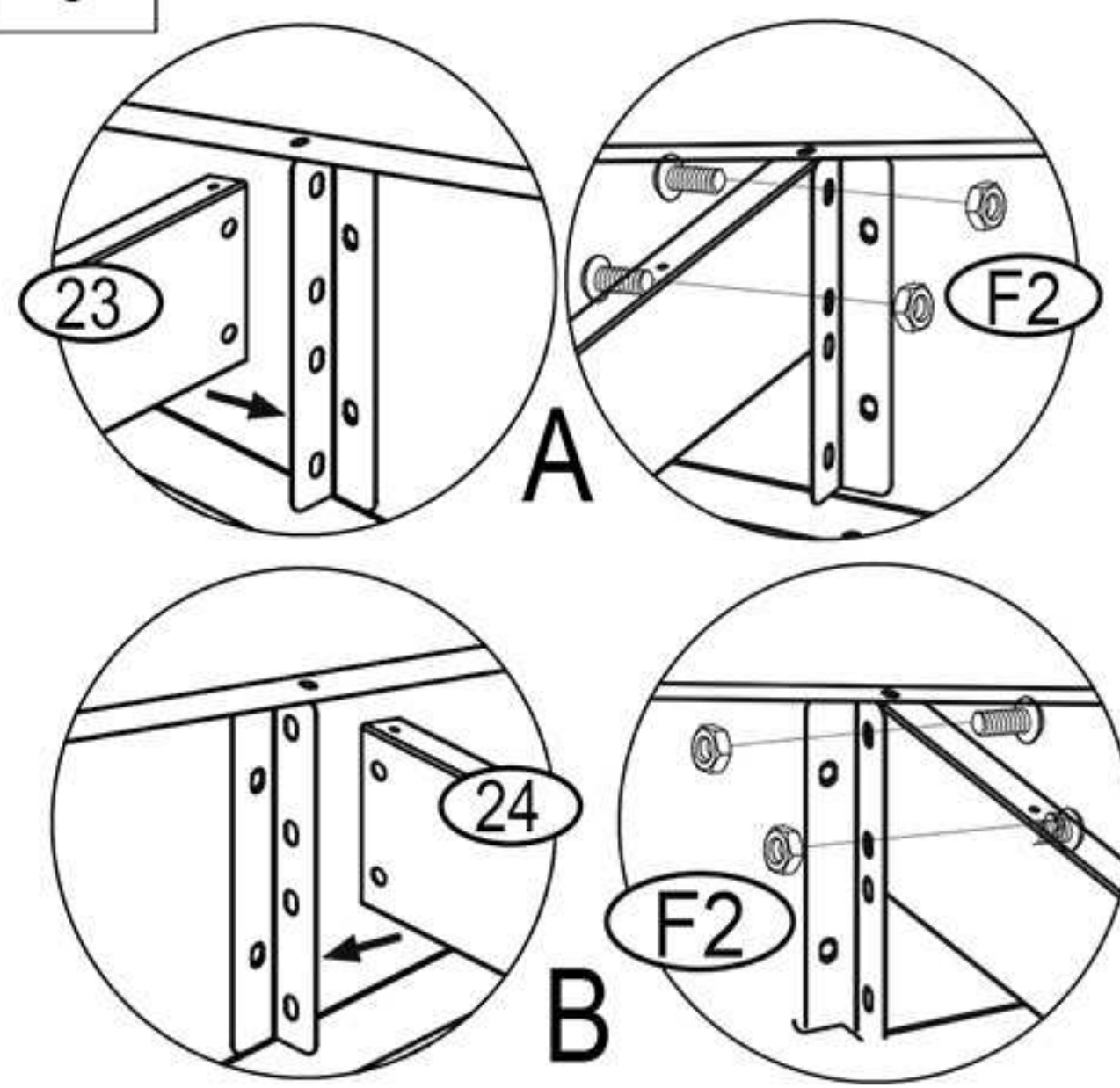

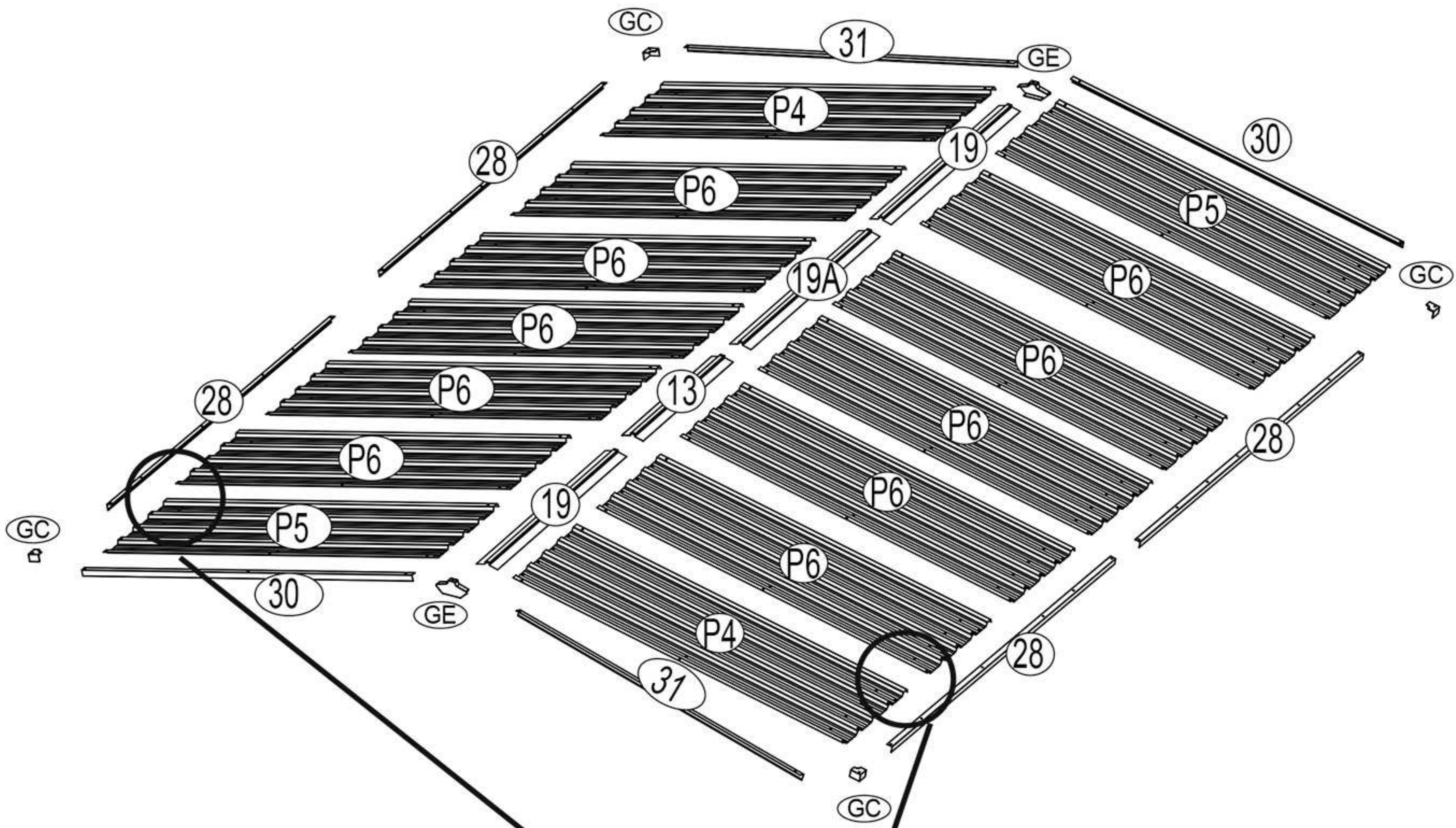

ta część jest tylko wodoodporna  
gdy jest przykryta z góry

this part is only waterproof  
when covered on top

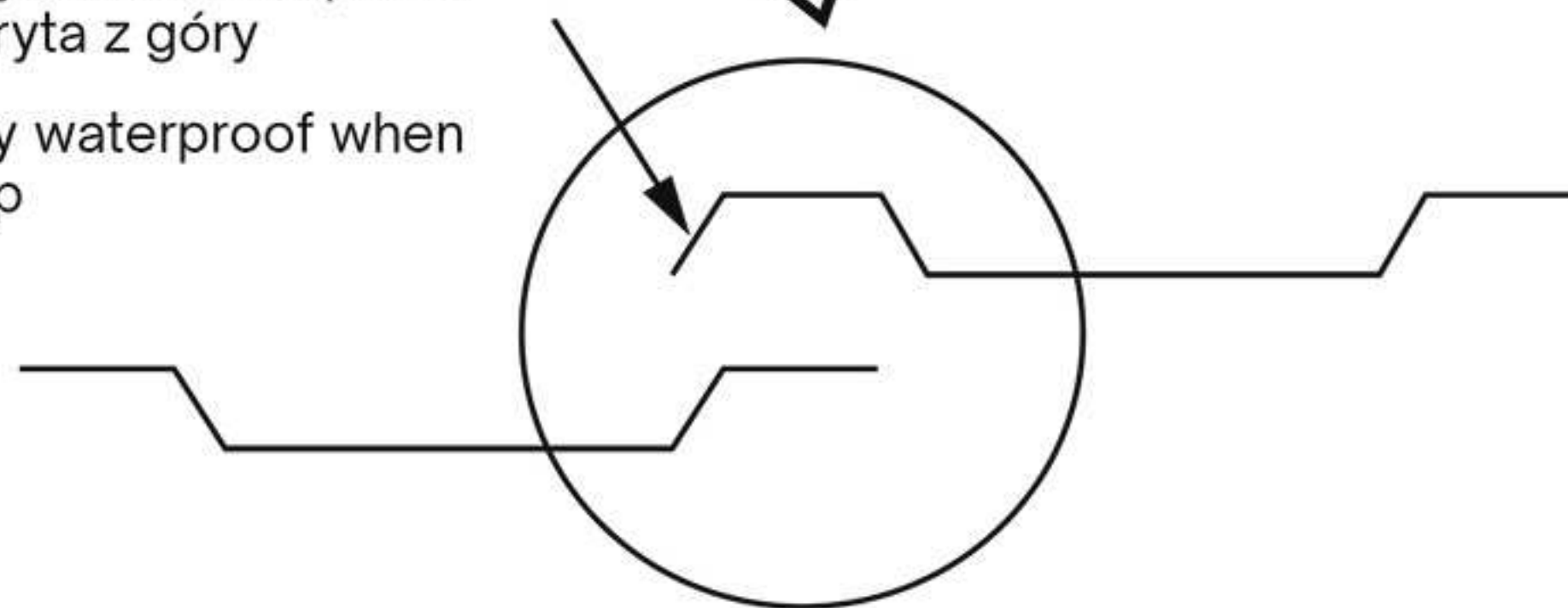

NO./NR	PART/ELEMENT	QTY./ ILOŚĆ
P4		1
P5		1
P6		2
F1		48
S3		48

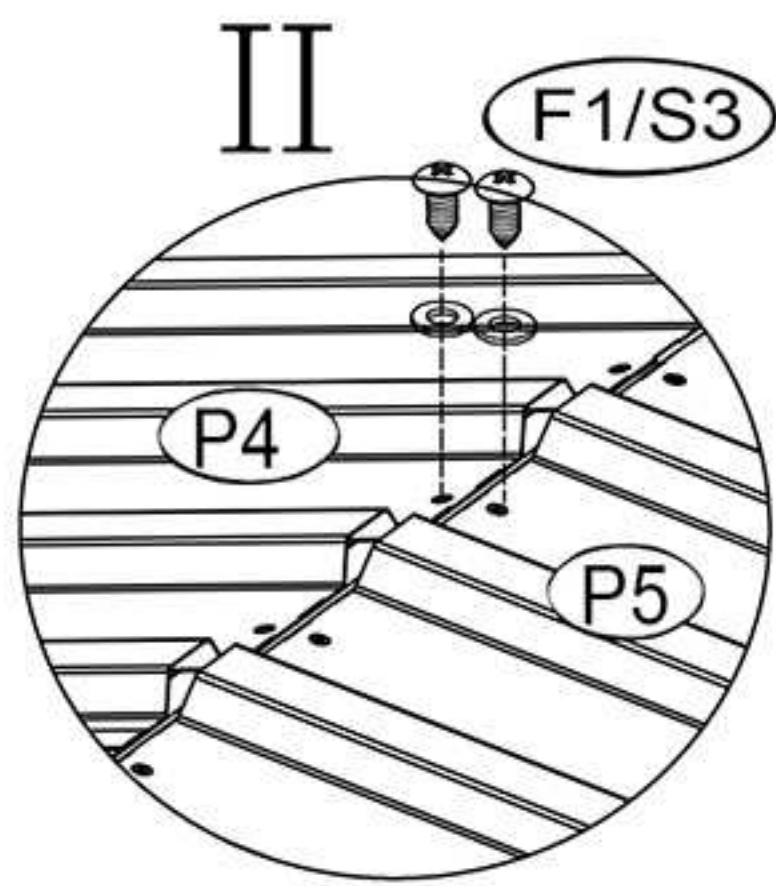
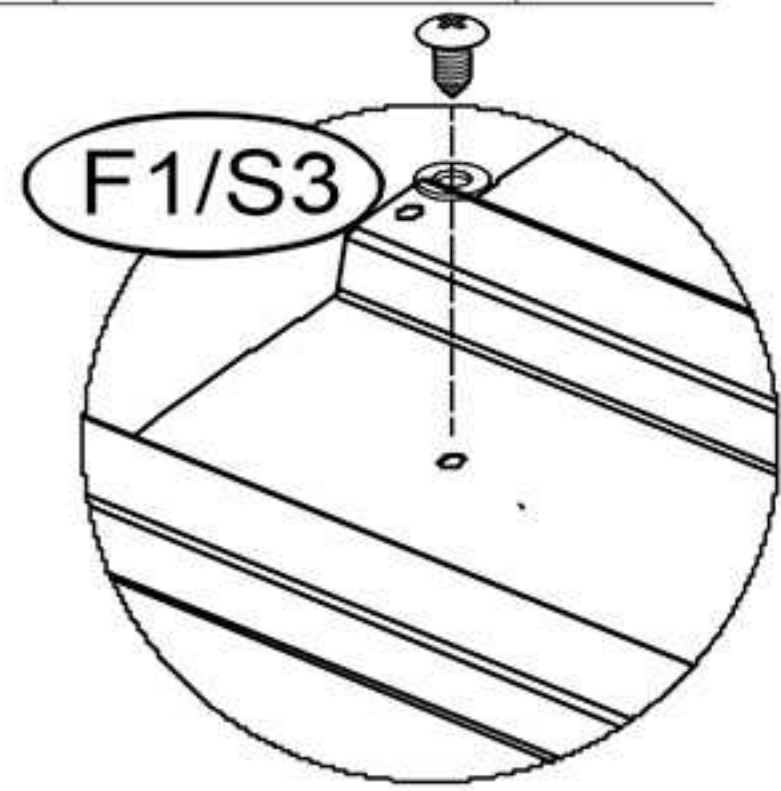

I

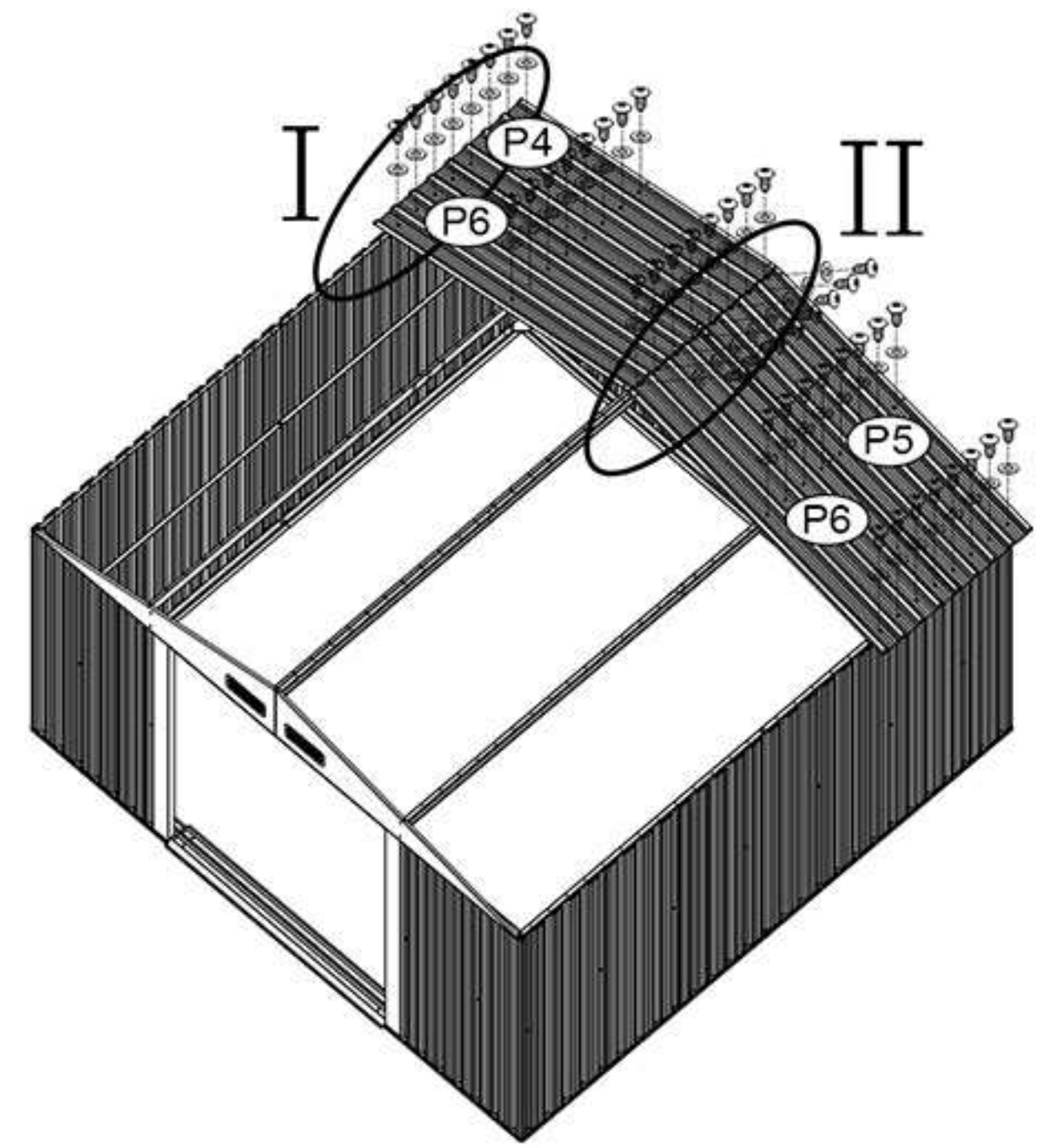

NO./NR	PART/ELEMENT	QTY./ ILOŚĆ
30		1
31		1
F2		2
S3		2

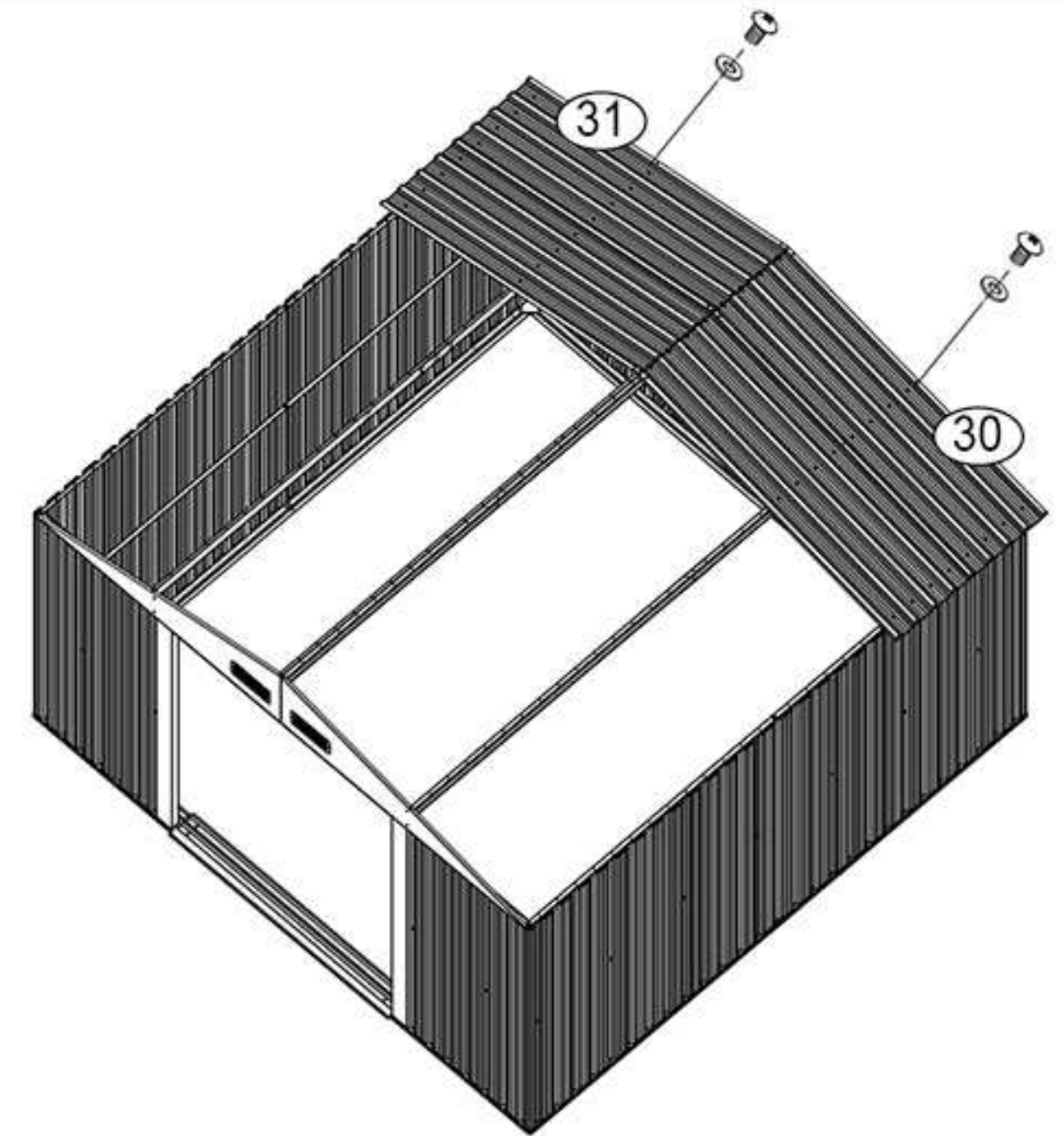
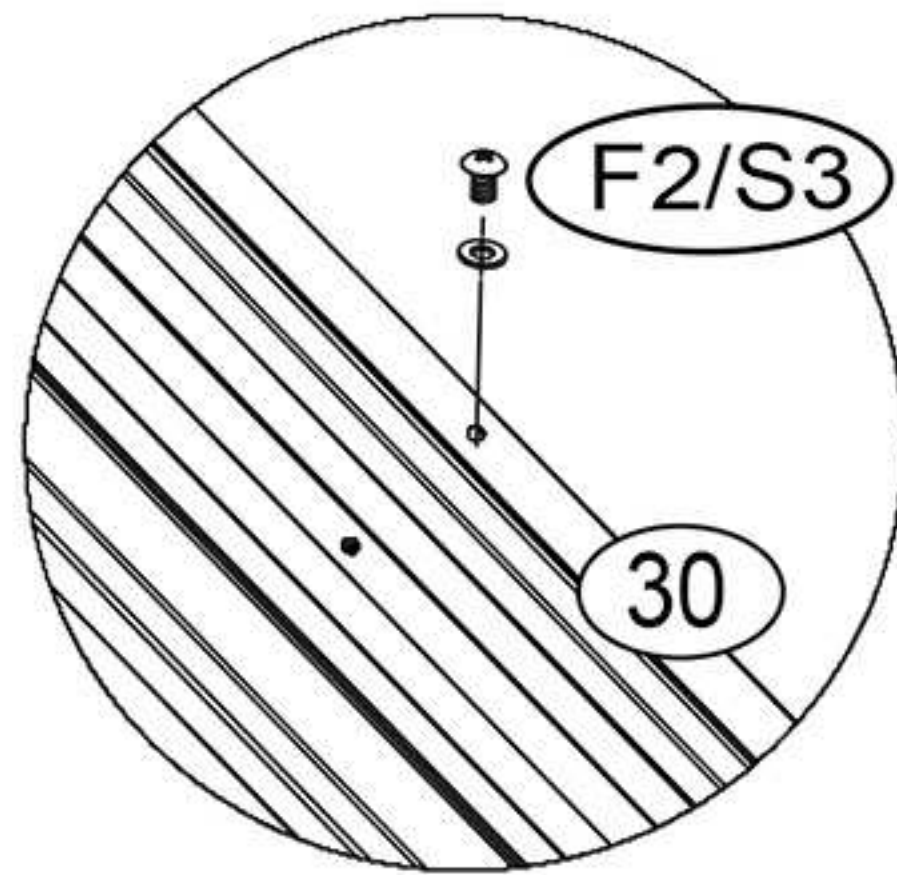

NO./NR	PART/ELEMENT	QTY./ ILOŚĆ
19		1
F2		4
S3		4

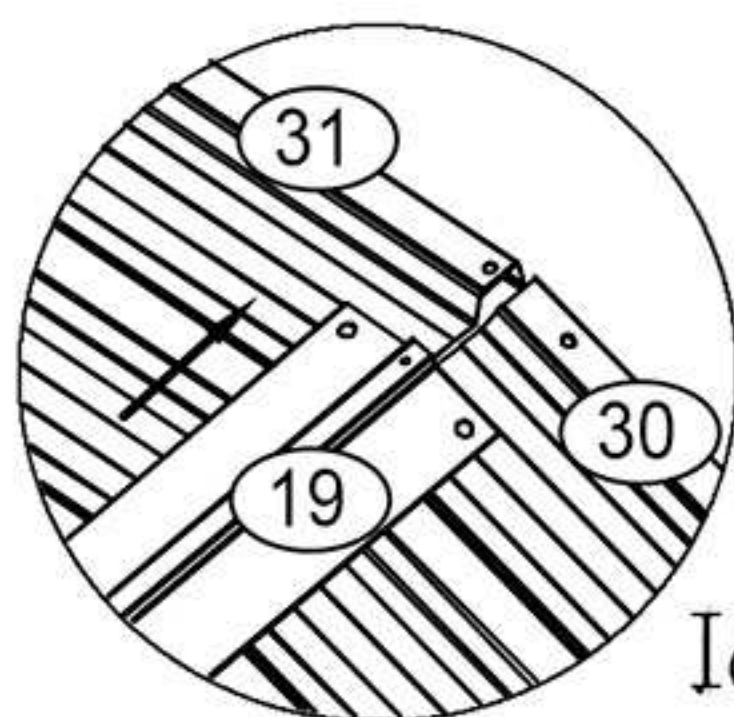

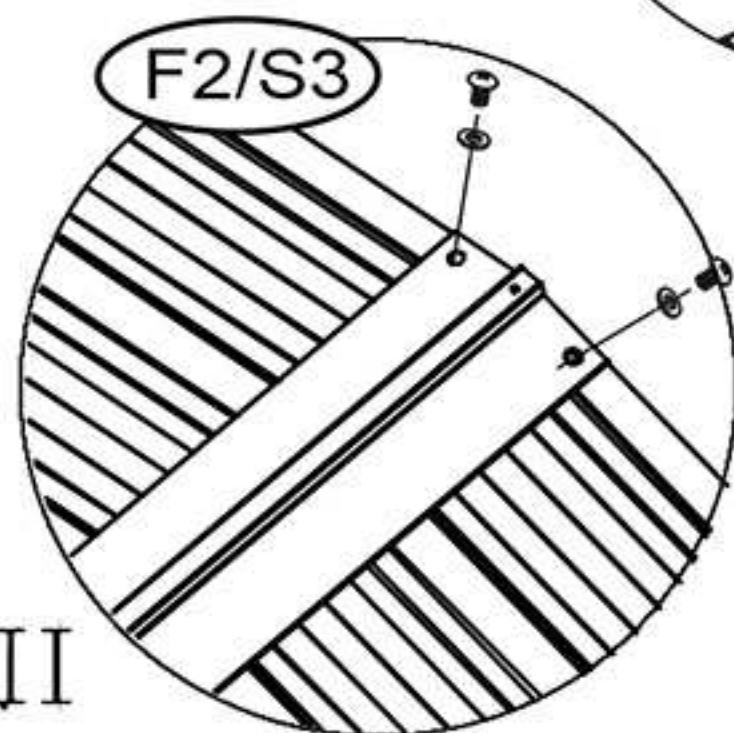

I&II

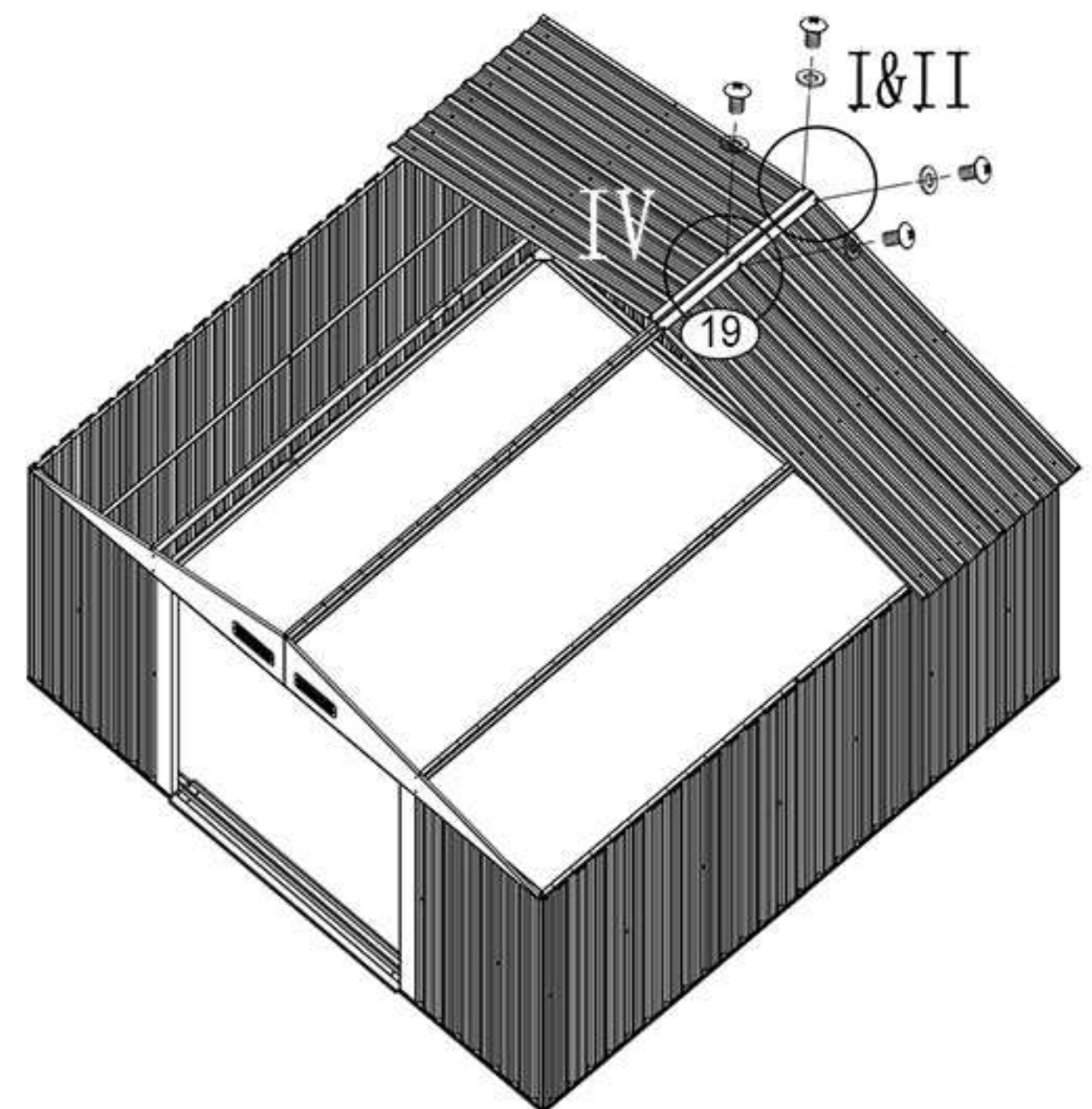
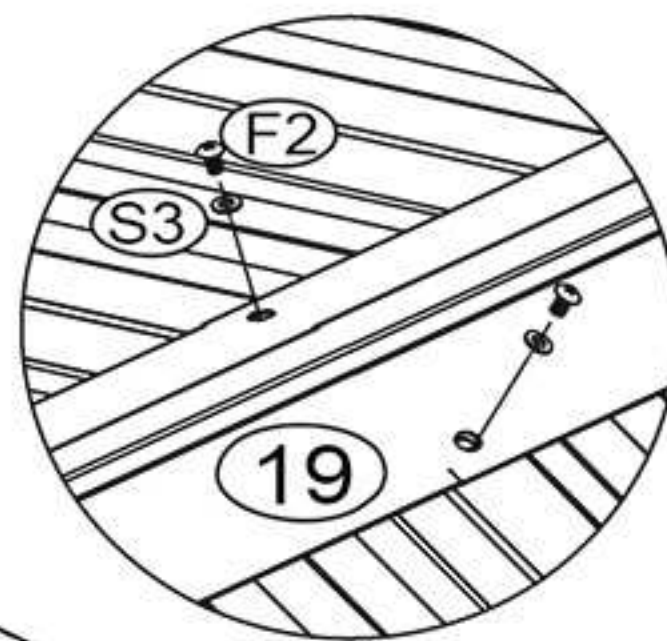

IV



NO./NR	PART/ELEMENT	QTY./ ILOŚĆ
P6		4
F1		48
S3		48

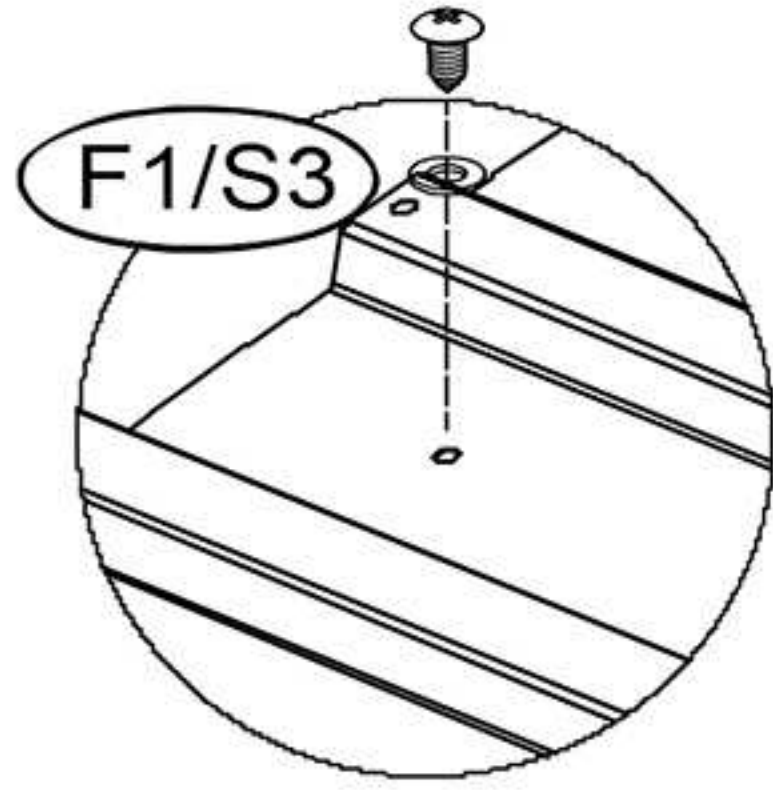

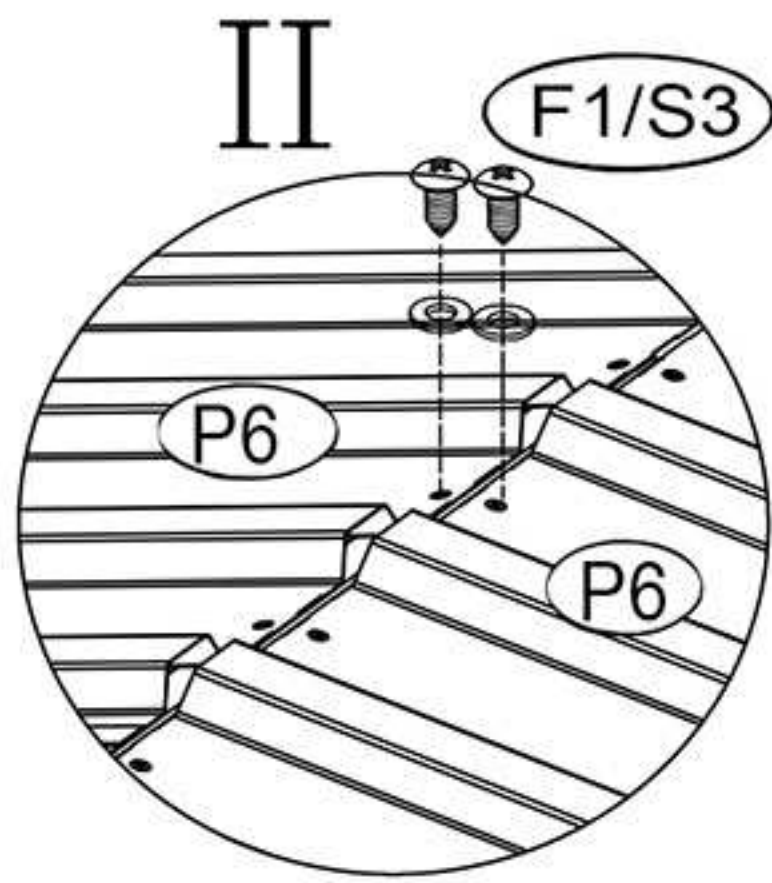

I

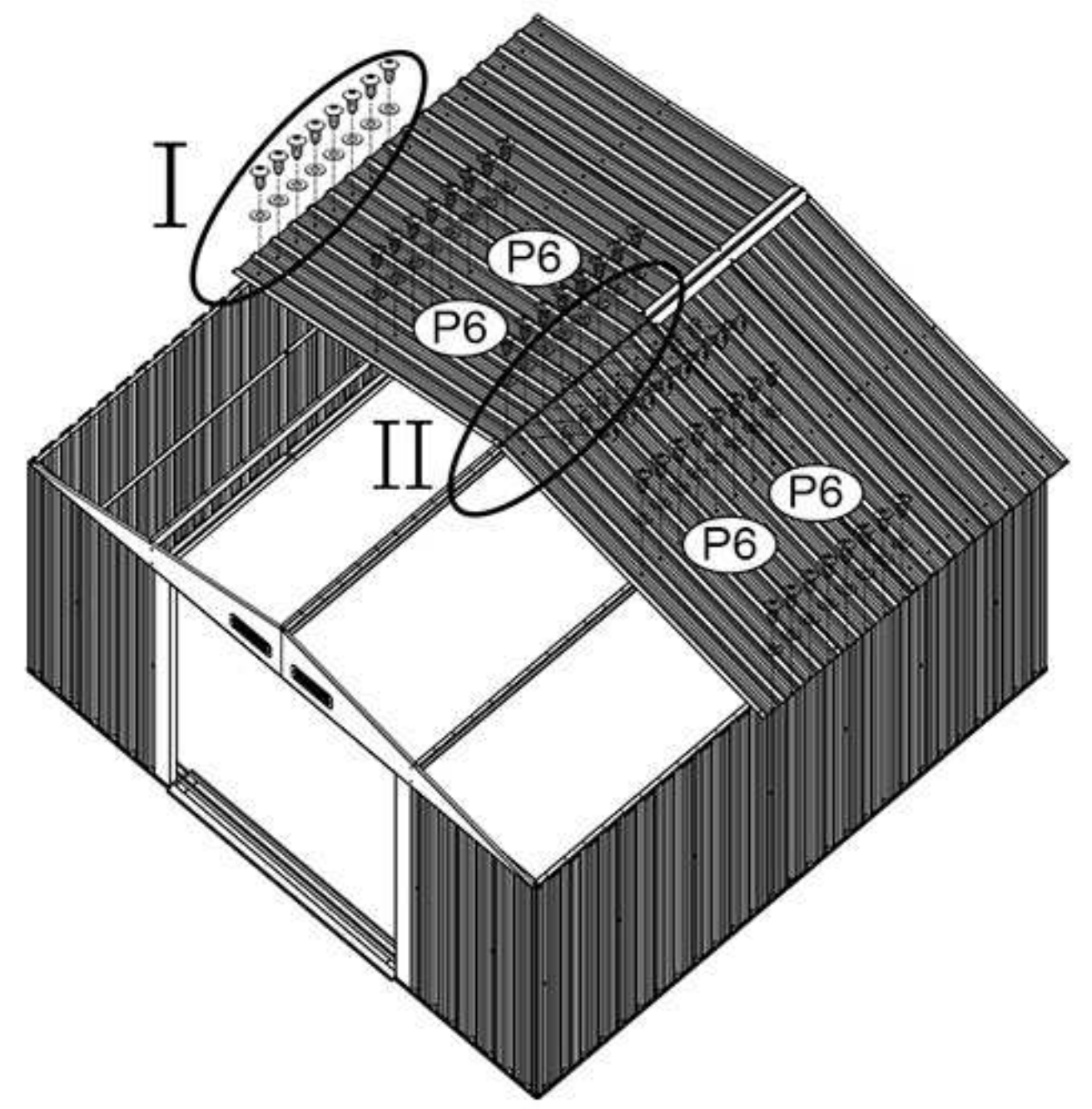

II

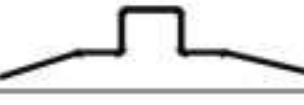



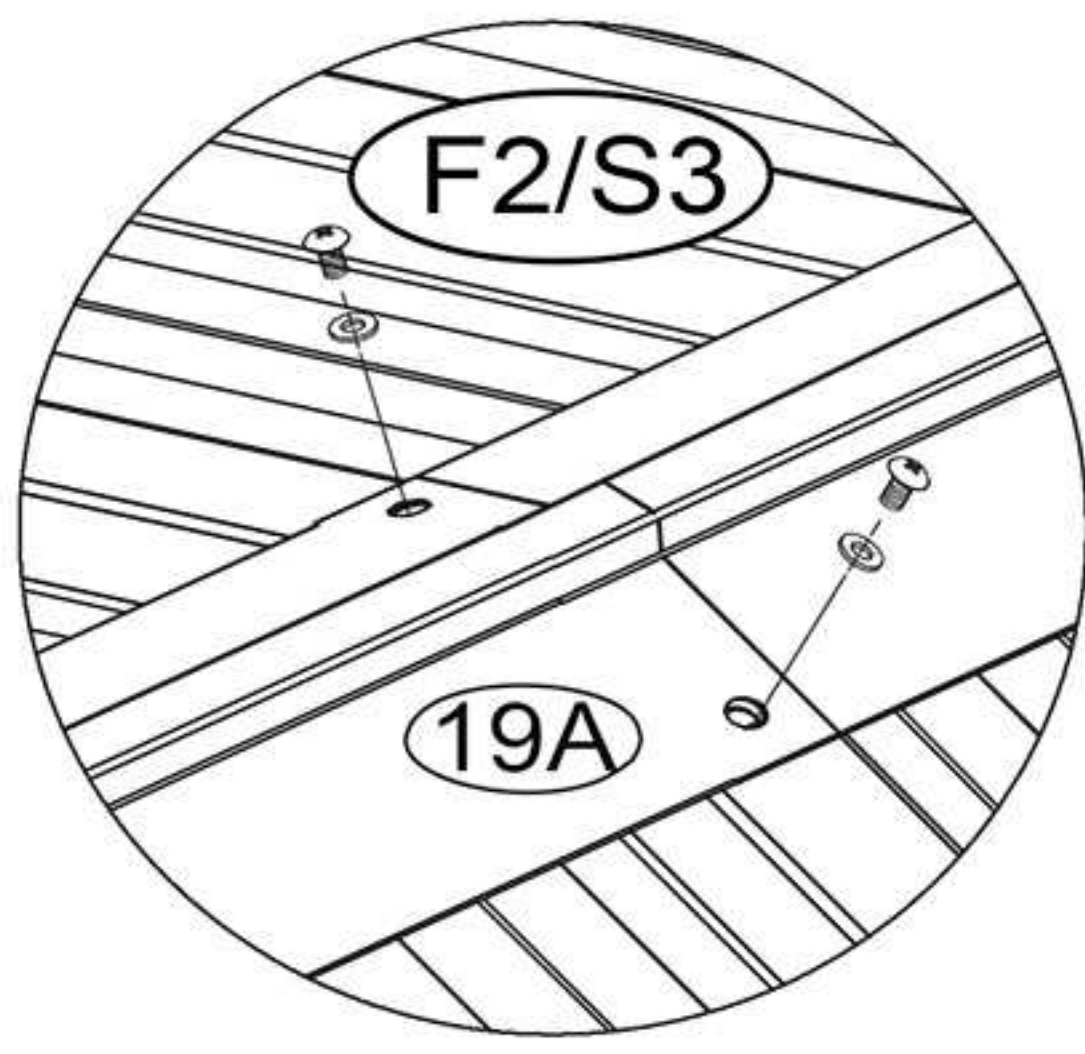

NO./NR	PART/ELEMENT	QTY./ ILOŚĆ
19A		1
F2		4
S3		4

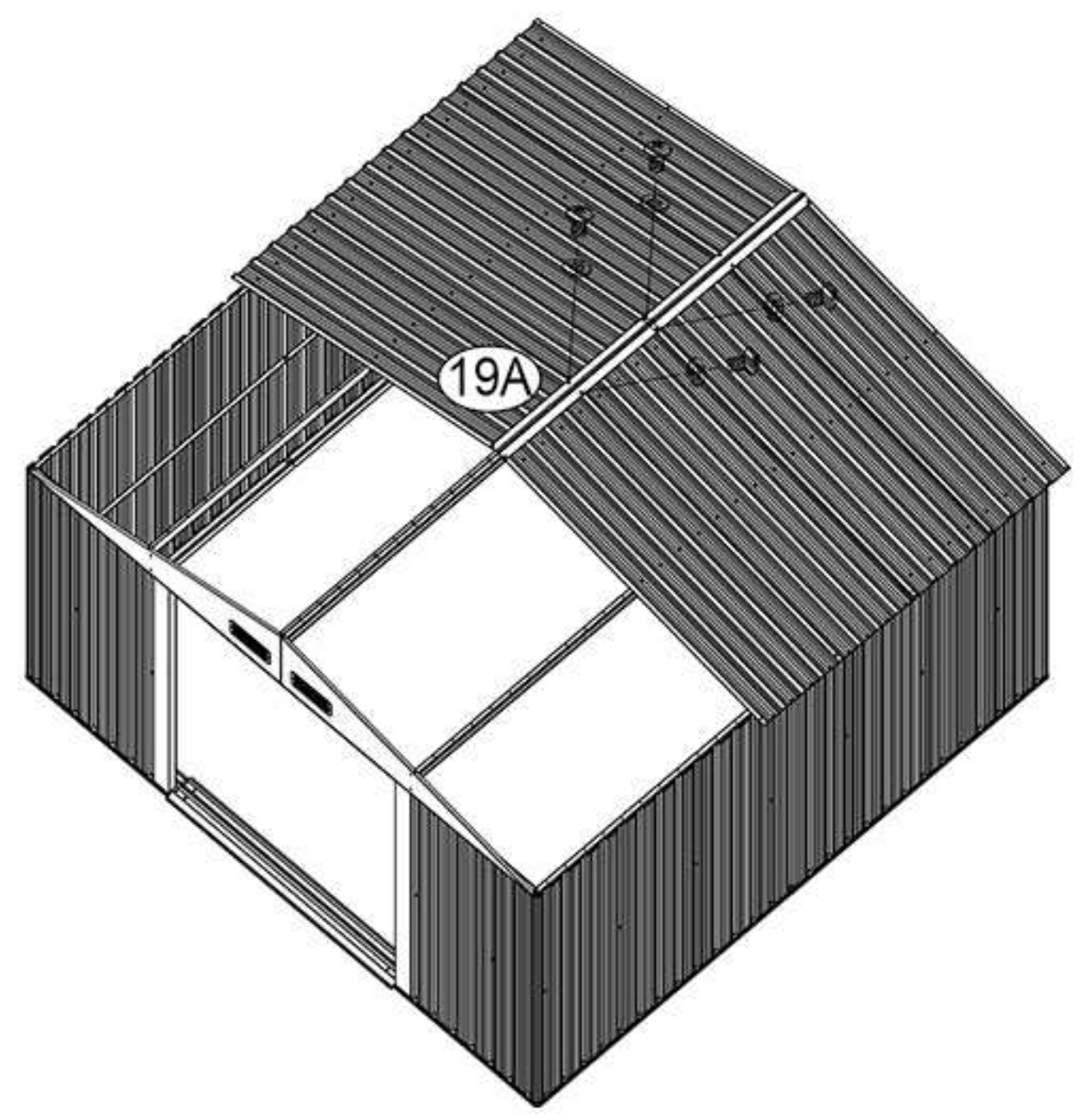

F2/S3

19A

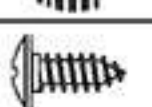

NO./NR	PART/ELEMENT	QTY./ ILOŚĆ
P6		2
F1		24
S3		24

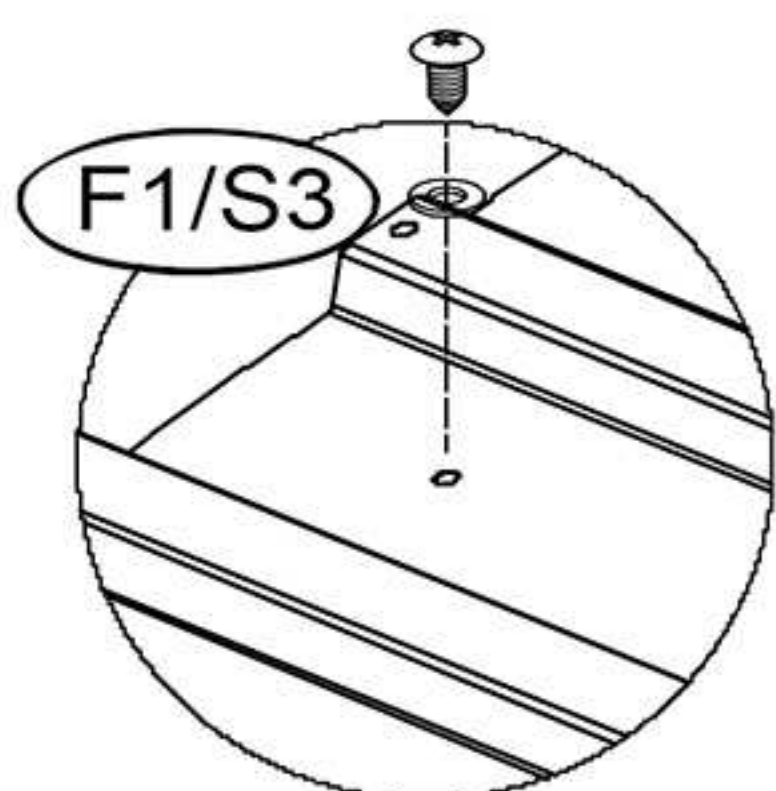

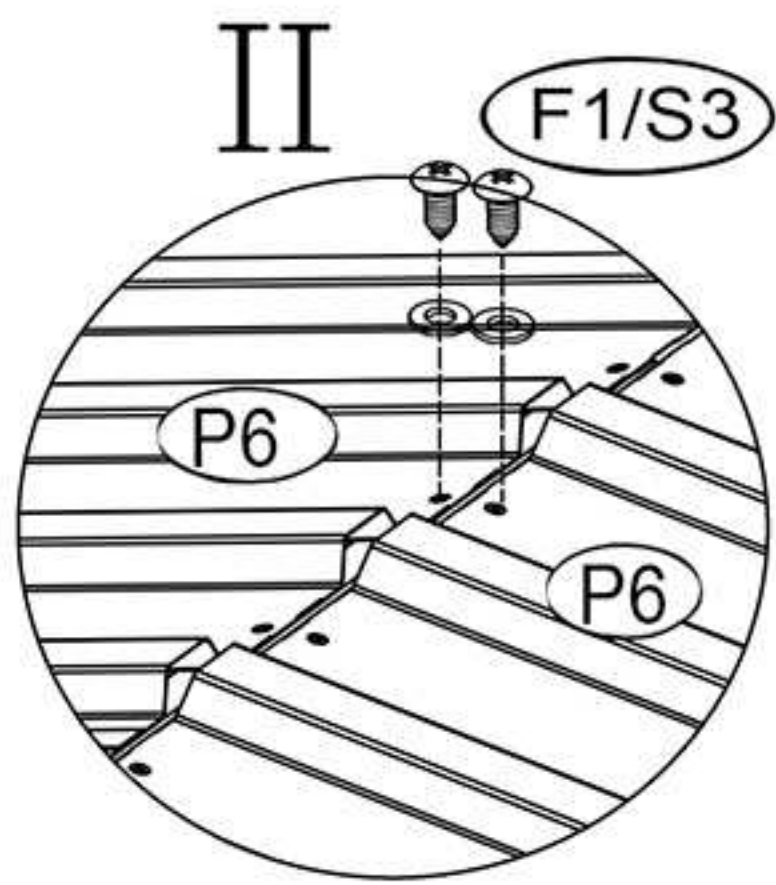

I



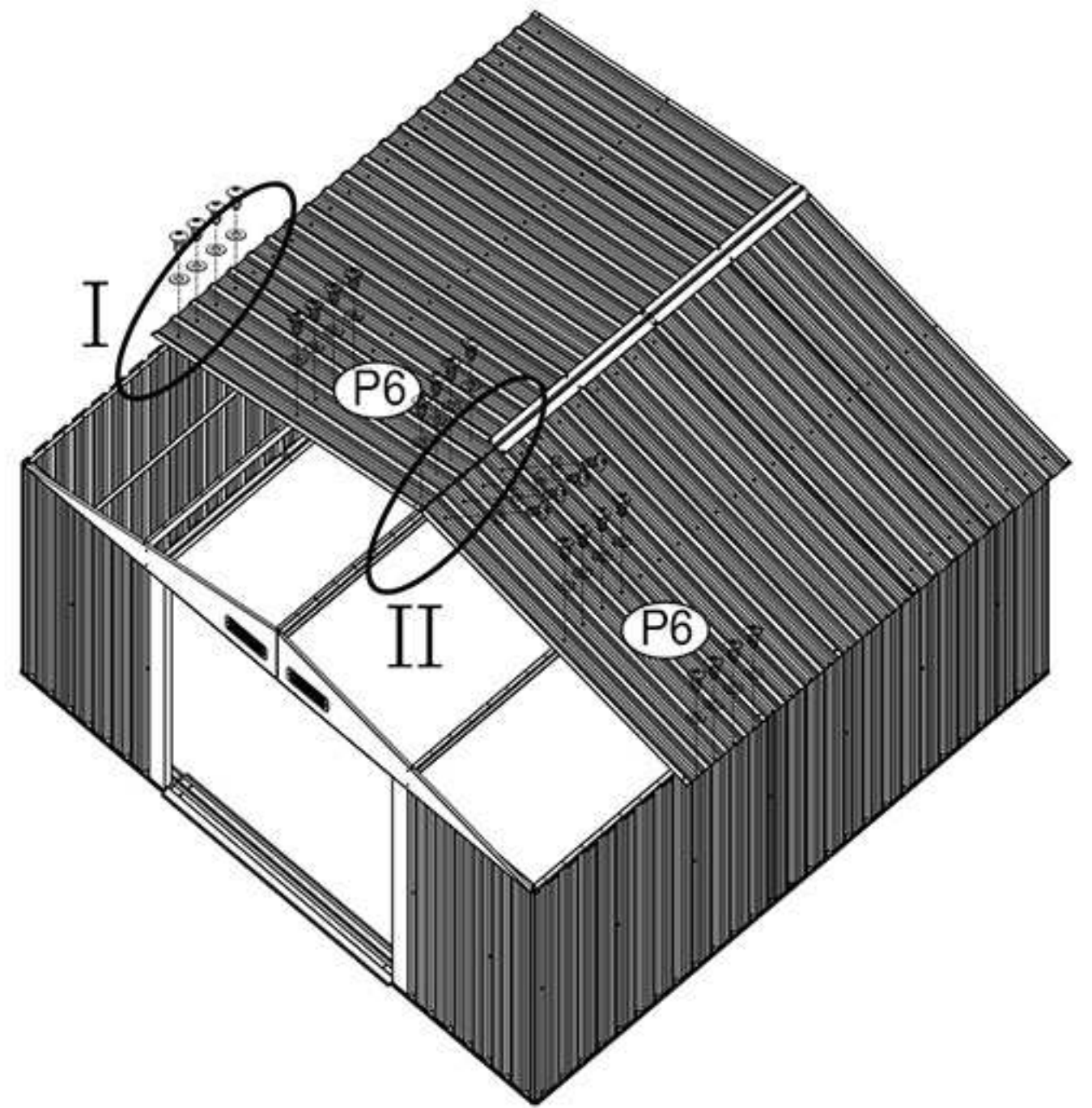



II

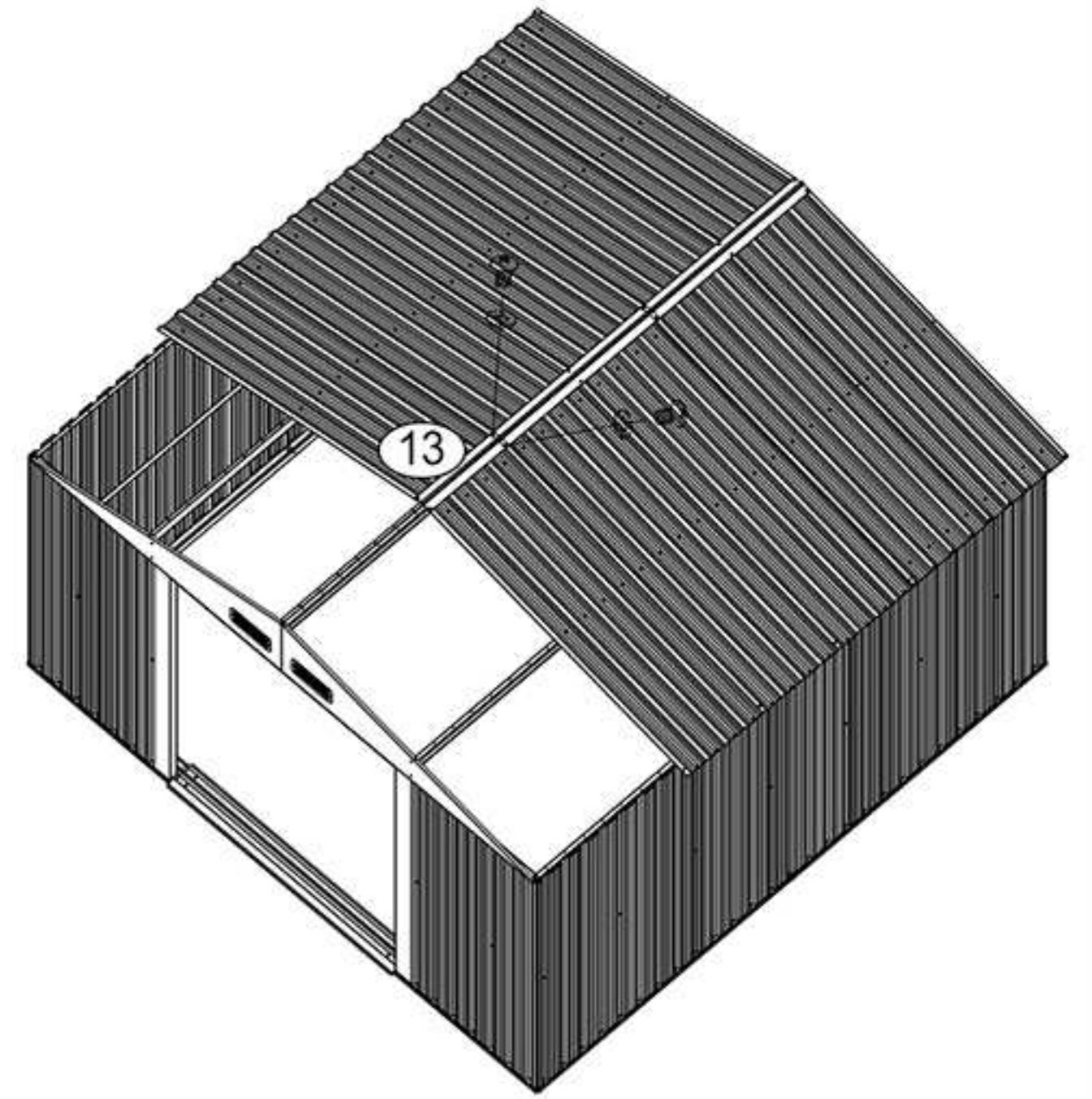
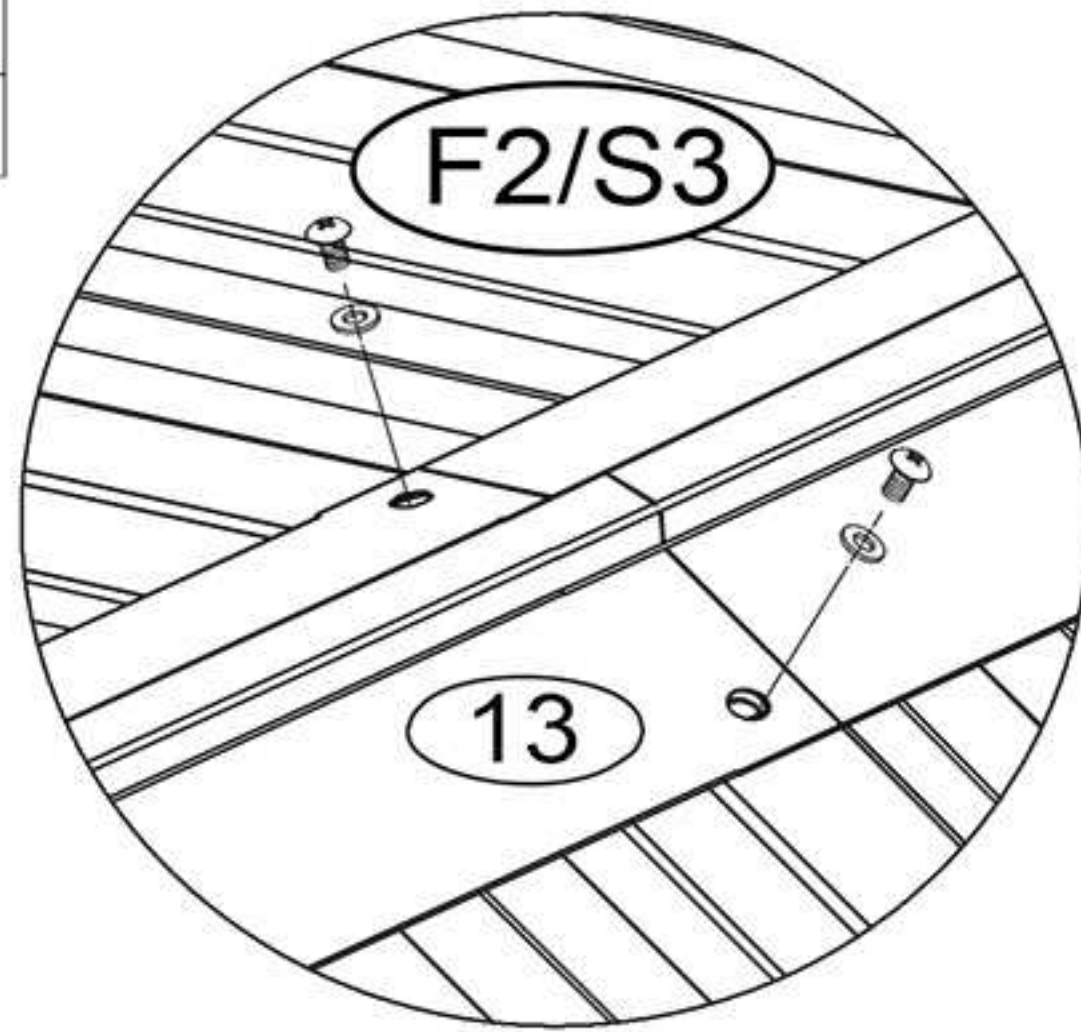



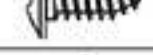

NO./NR	PART/ELEMENT	QTY./ ILOŚĆ
13		1
F2		2
S3		2

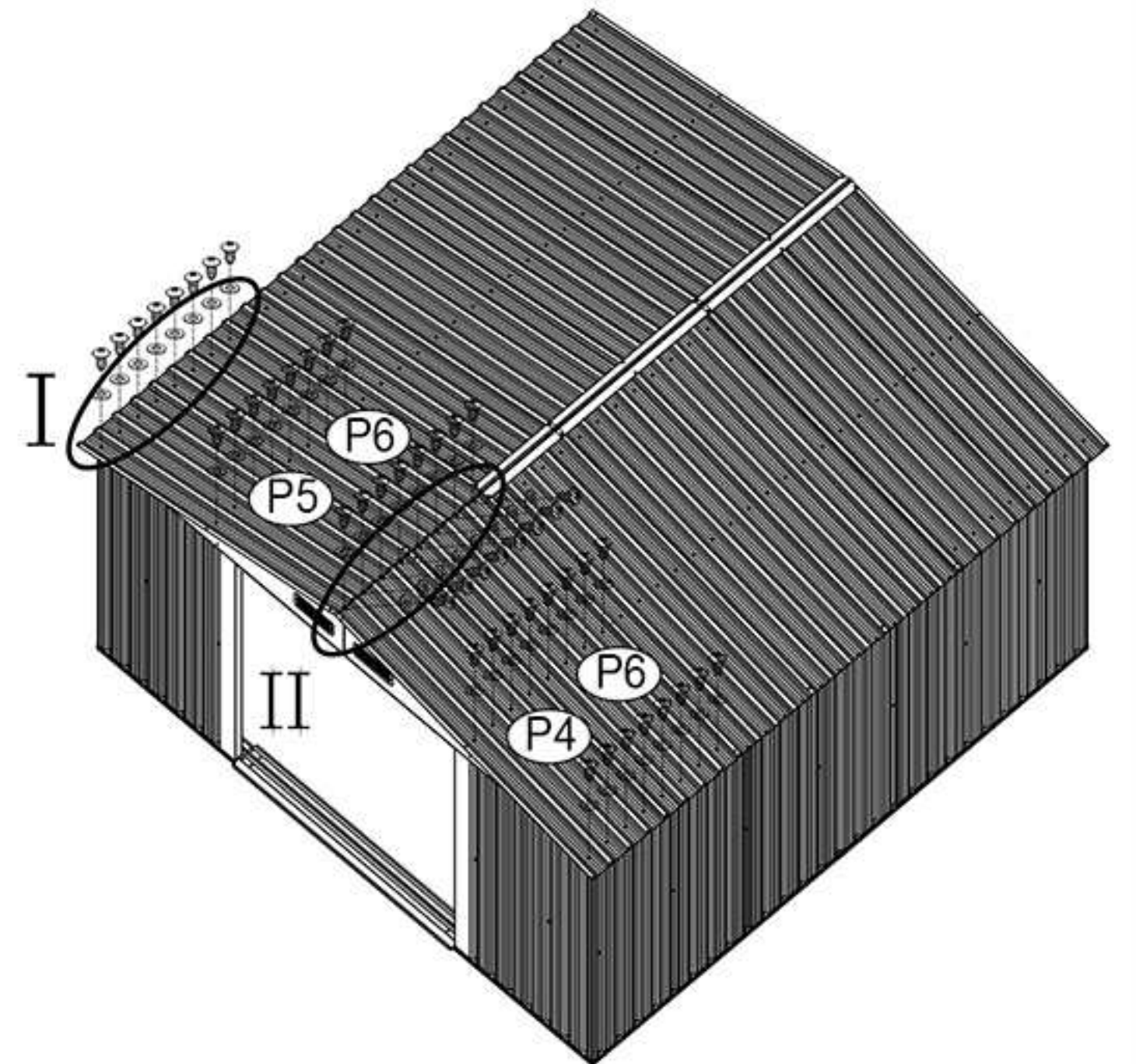
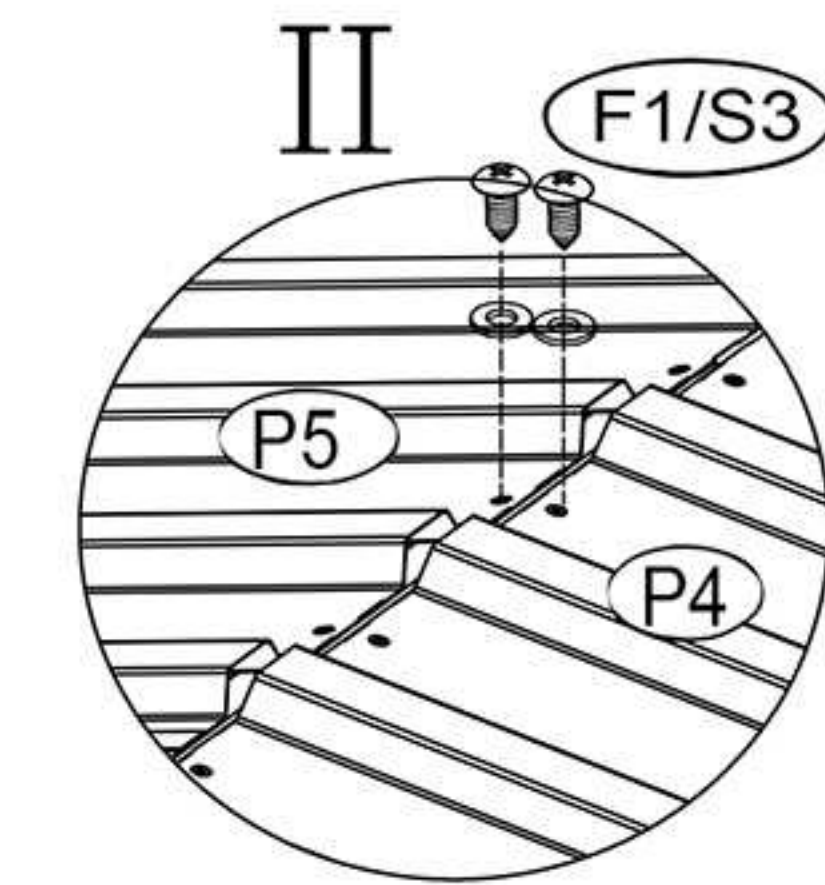
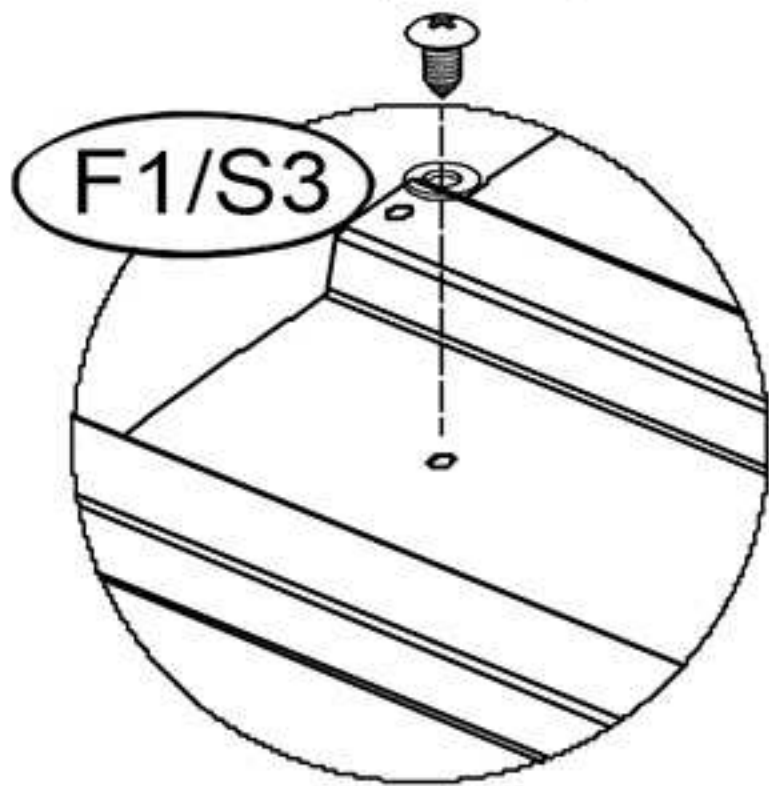

NO./NR	PART/ELEMENT	QTY./ ILOŚĆ
P4		1
P5		1
P6		2
F1		48
S3		48

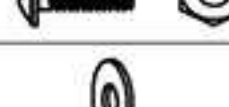

NO./NR	PART/ELEMENT	QTY./ ILOŚĆ
30		1
31		1
F2		2
S3		2

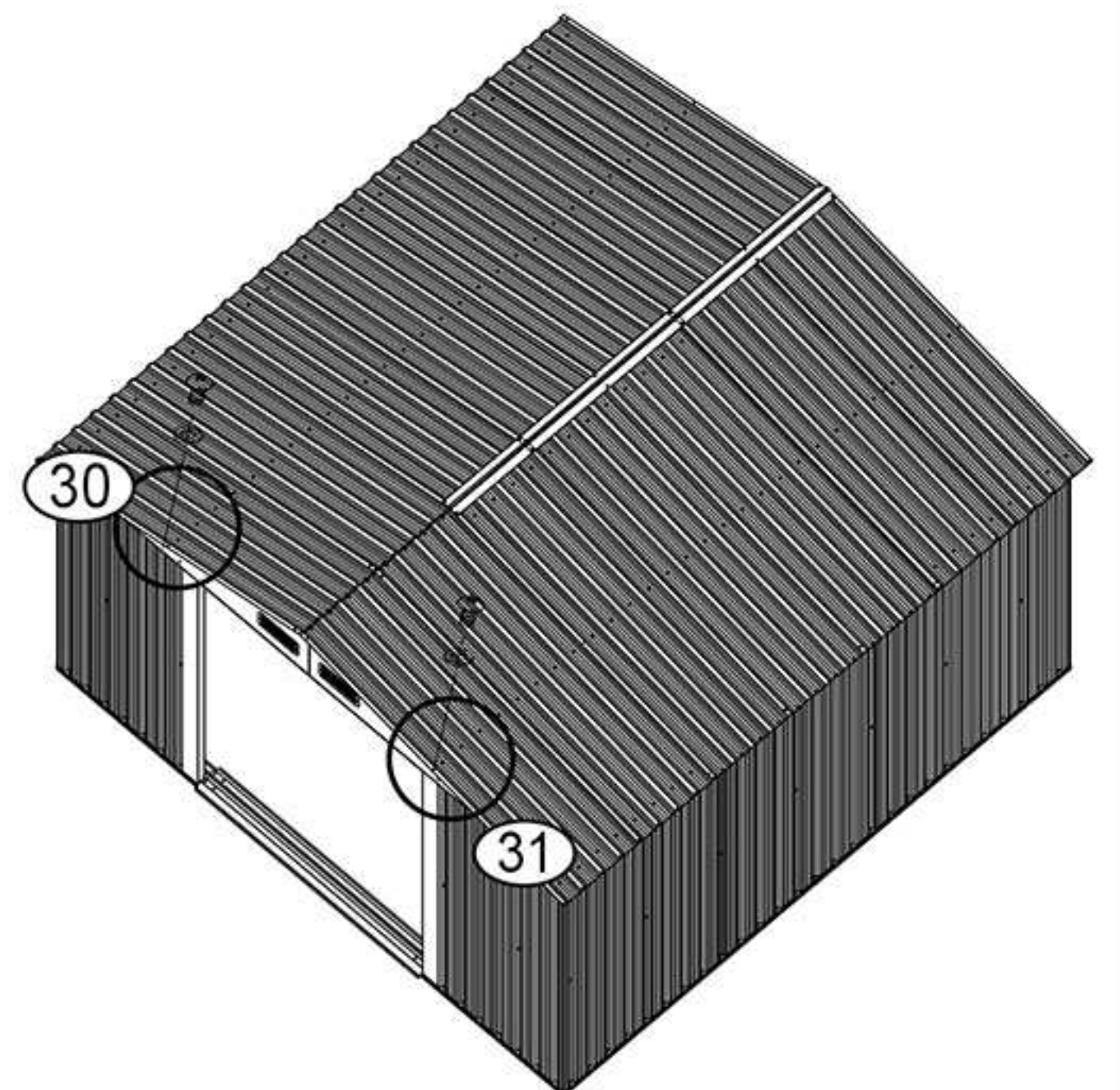
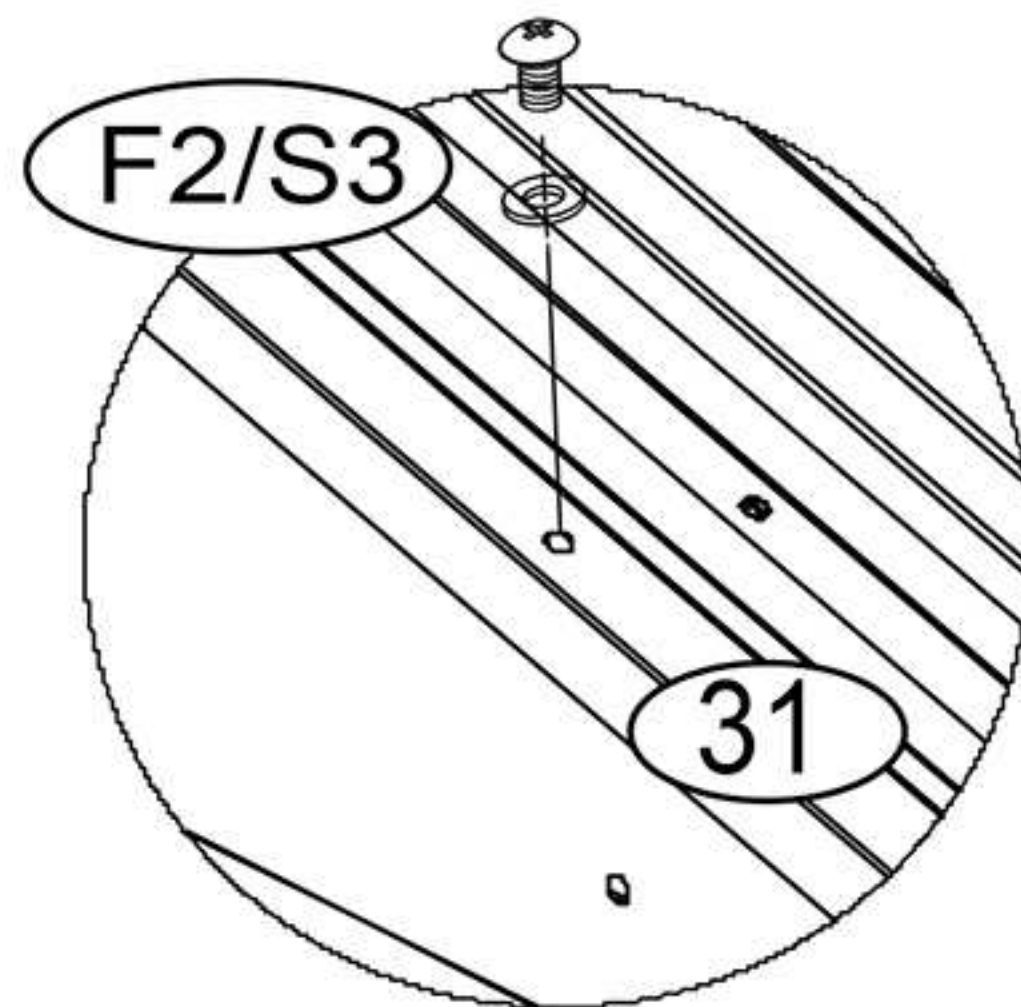



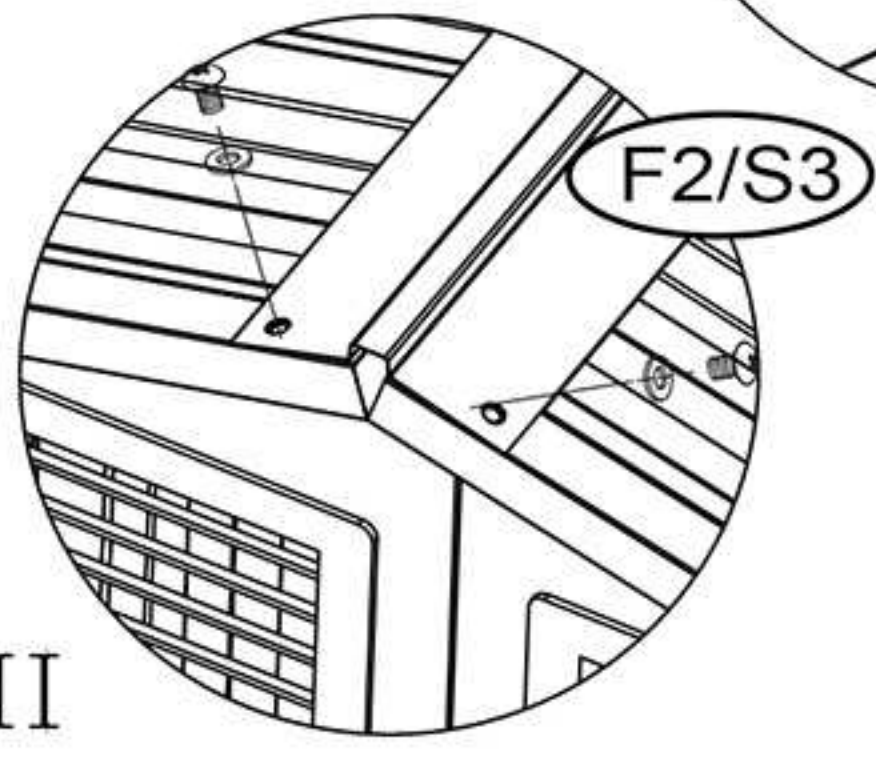
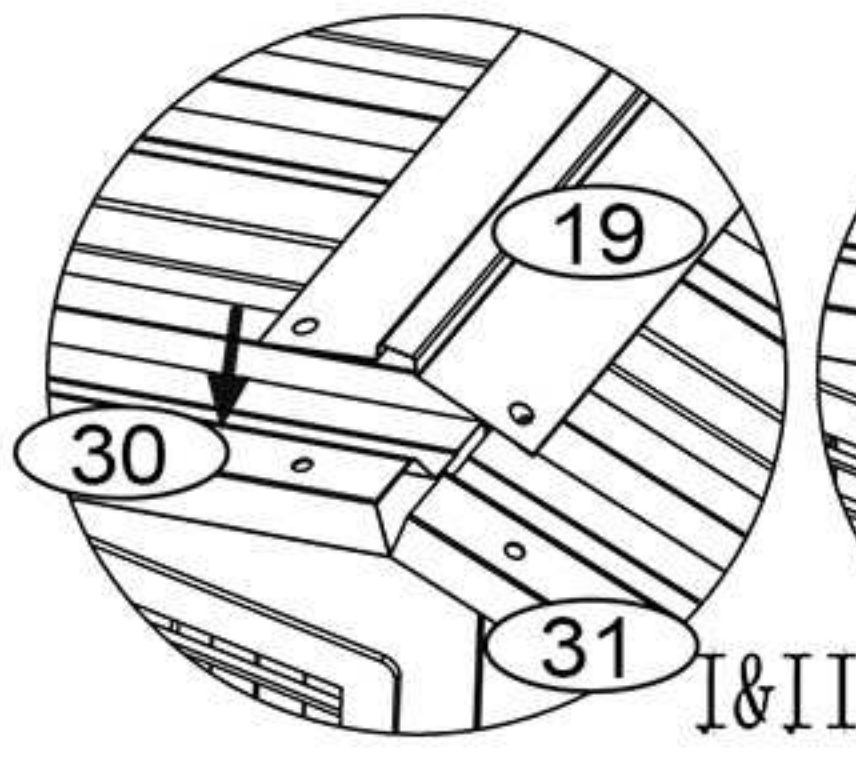
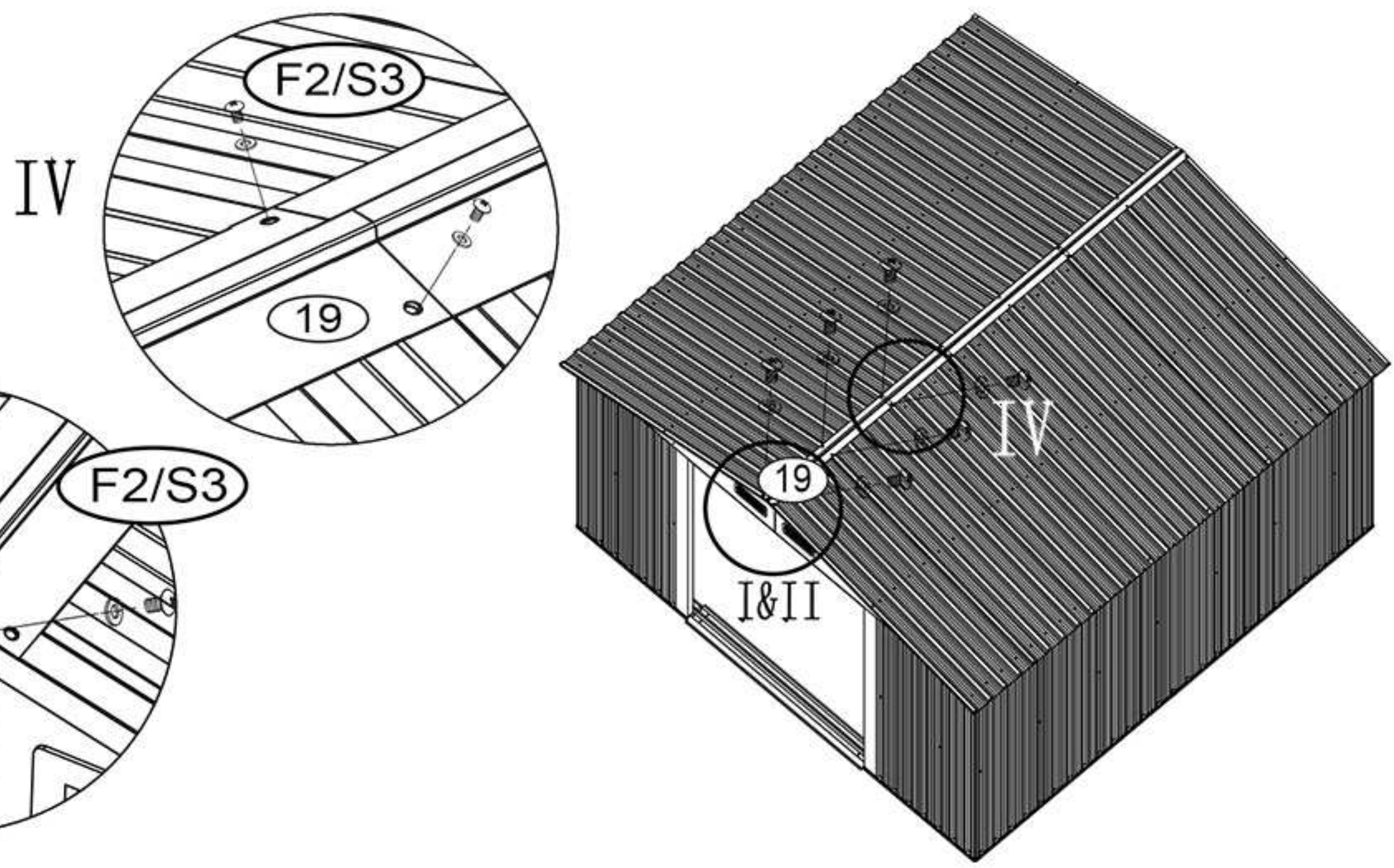

NO./NR	PART/ELEMENT	QTY./ ILOŚĆ
19		1
F2		6
S3		6

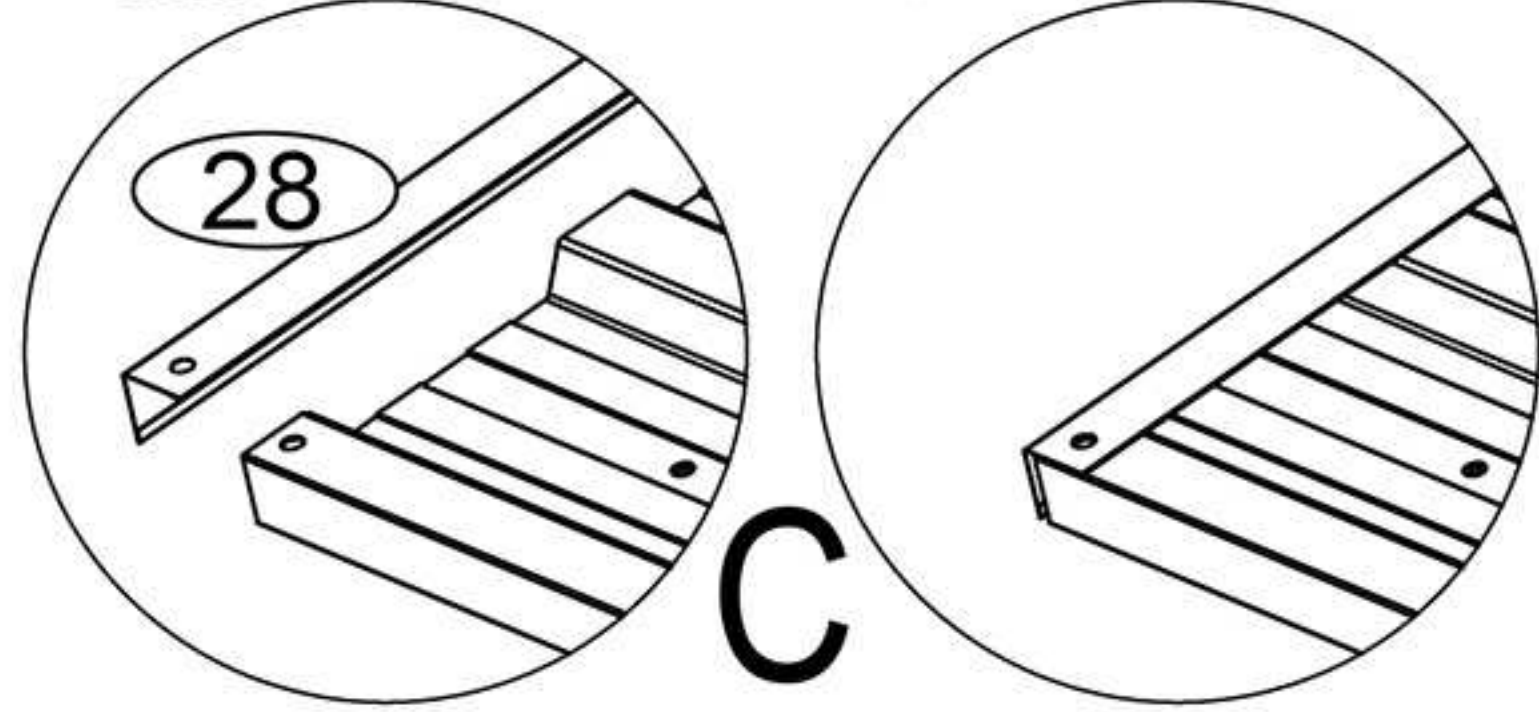
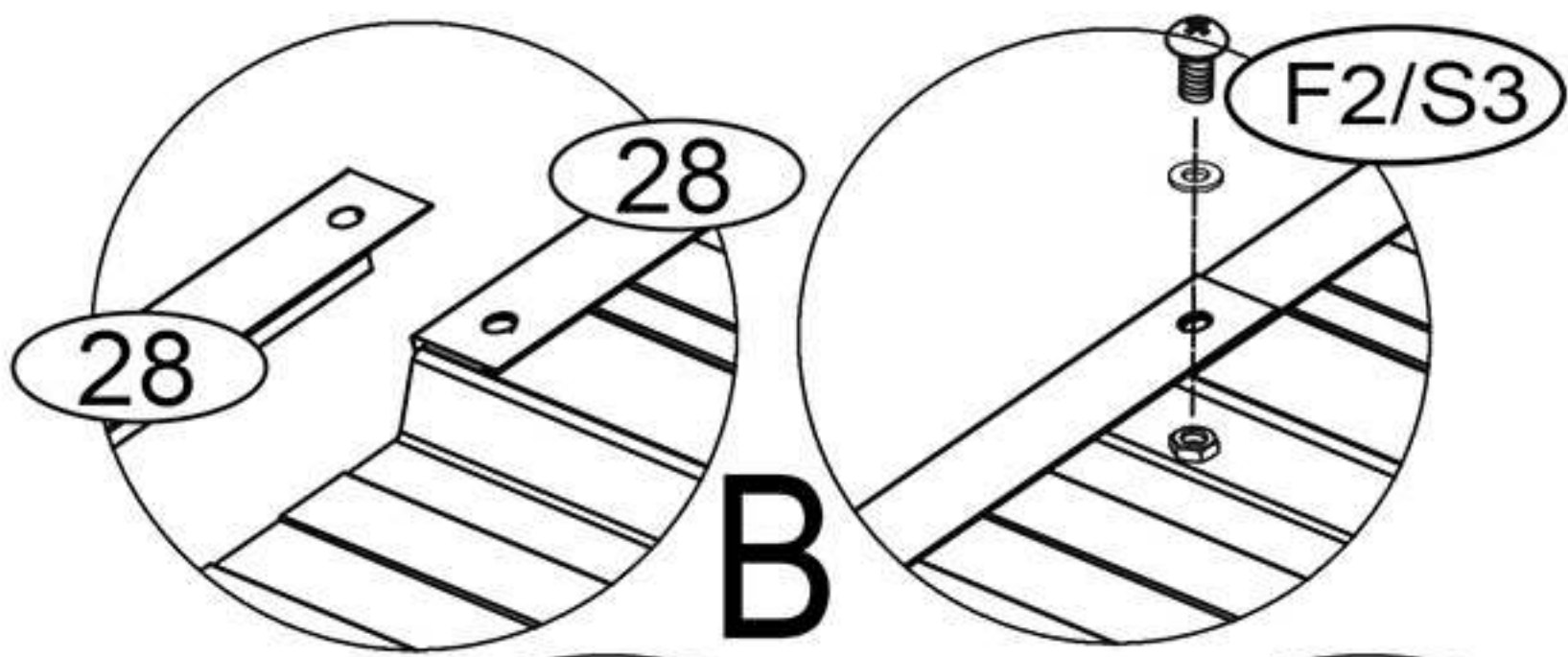
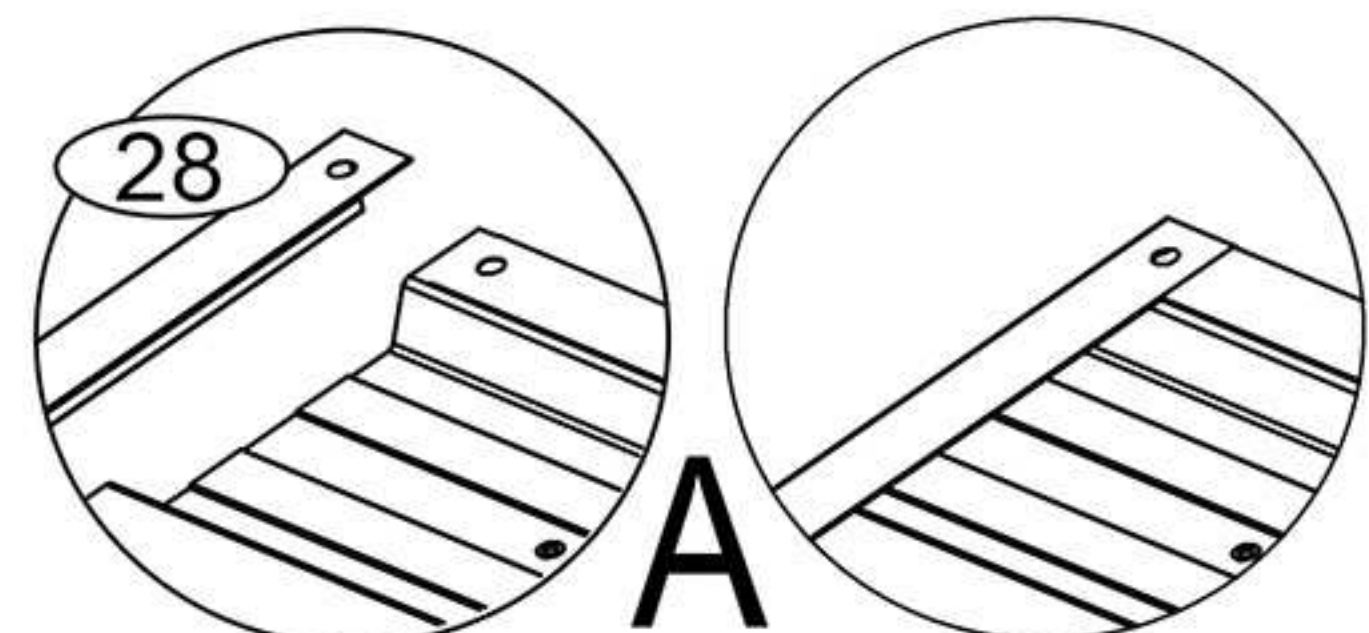
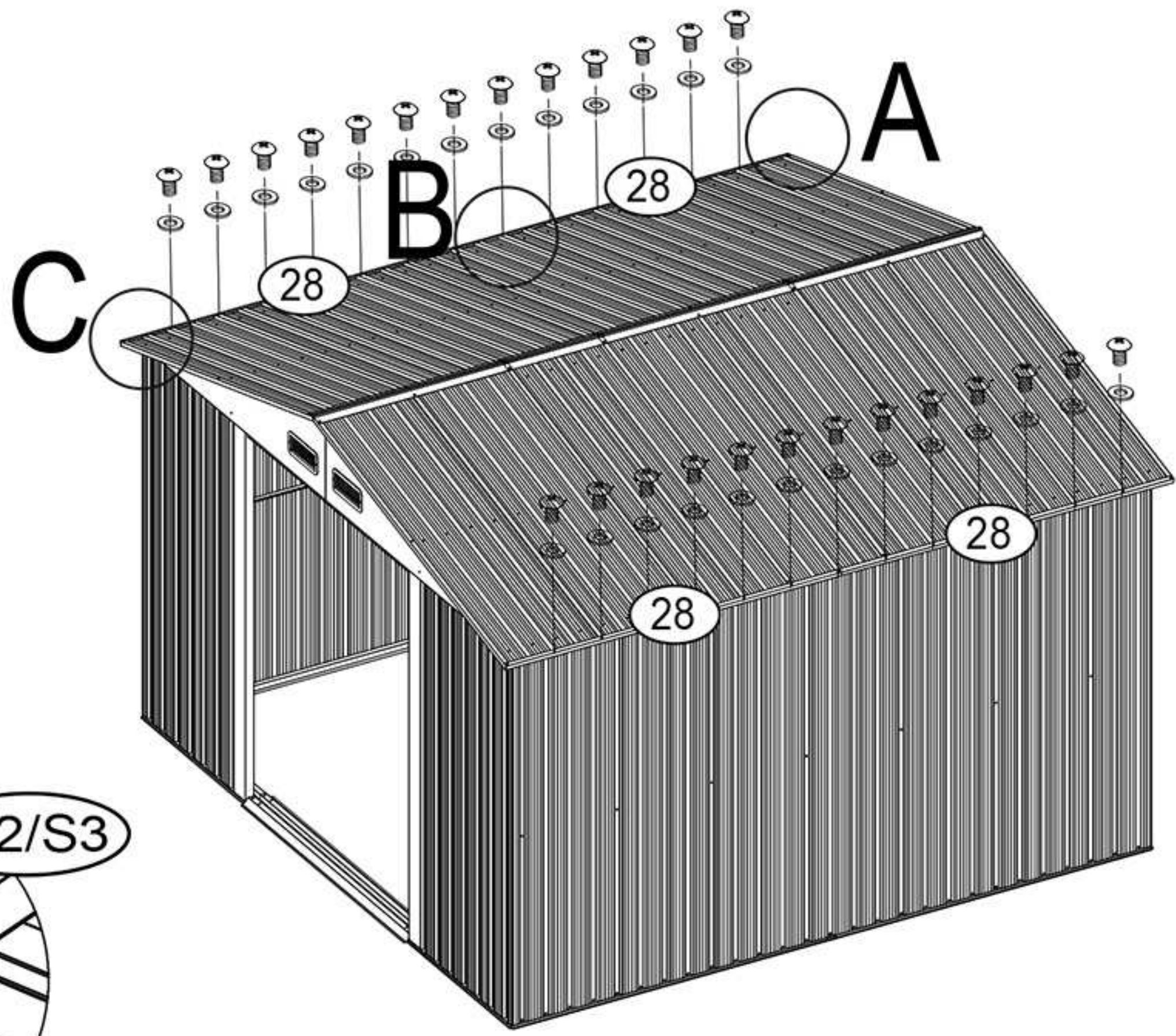

NO./NR	PART/ELEMENT	QTY./ ILOŚĆ
28		4
F2		26
S3		26

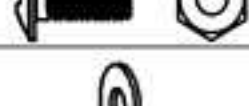

NO./NR	PART/ELEMENT	QTY./ ILOŚĆ
GC		4
GE		2
F1		2
F2		4
S3		2

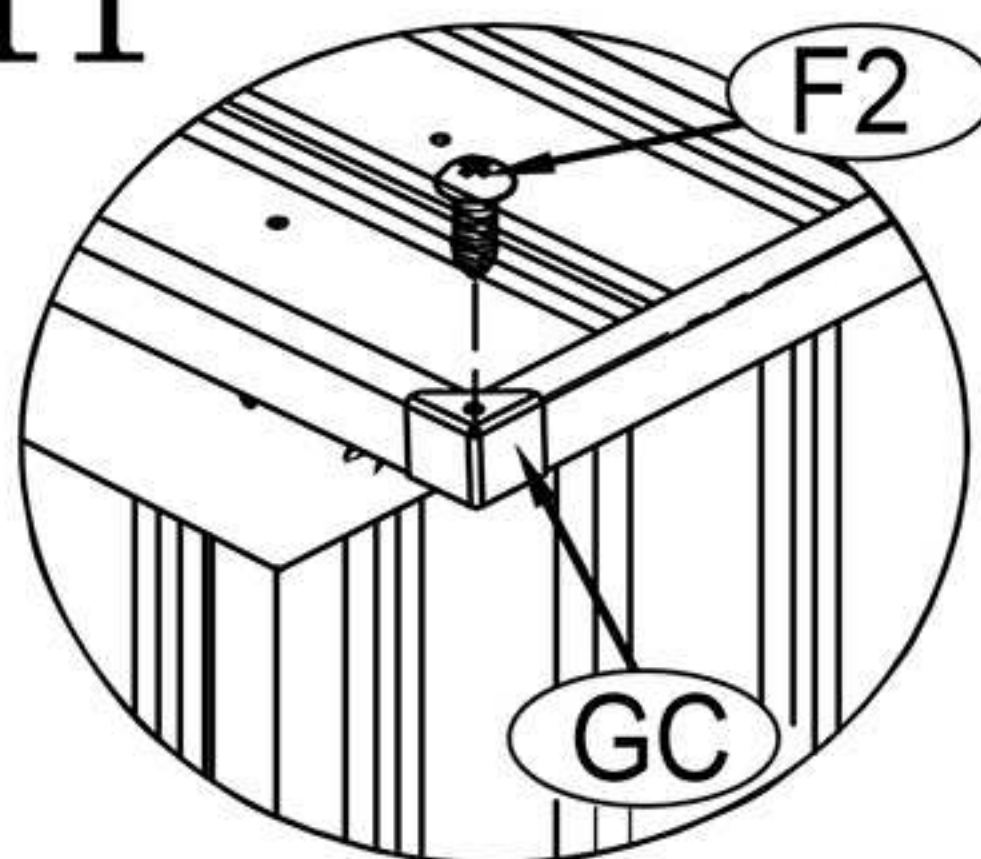
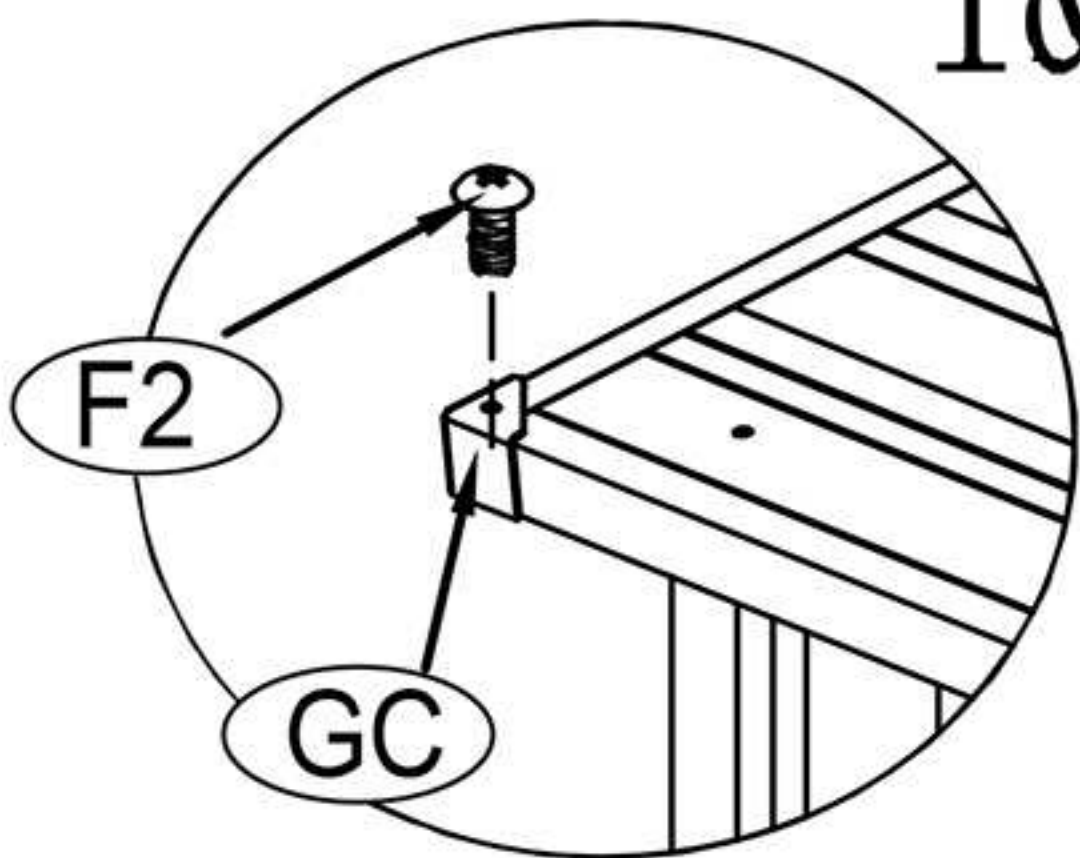
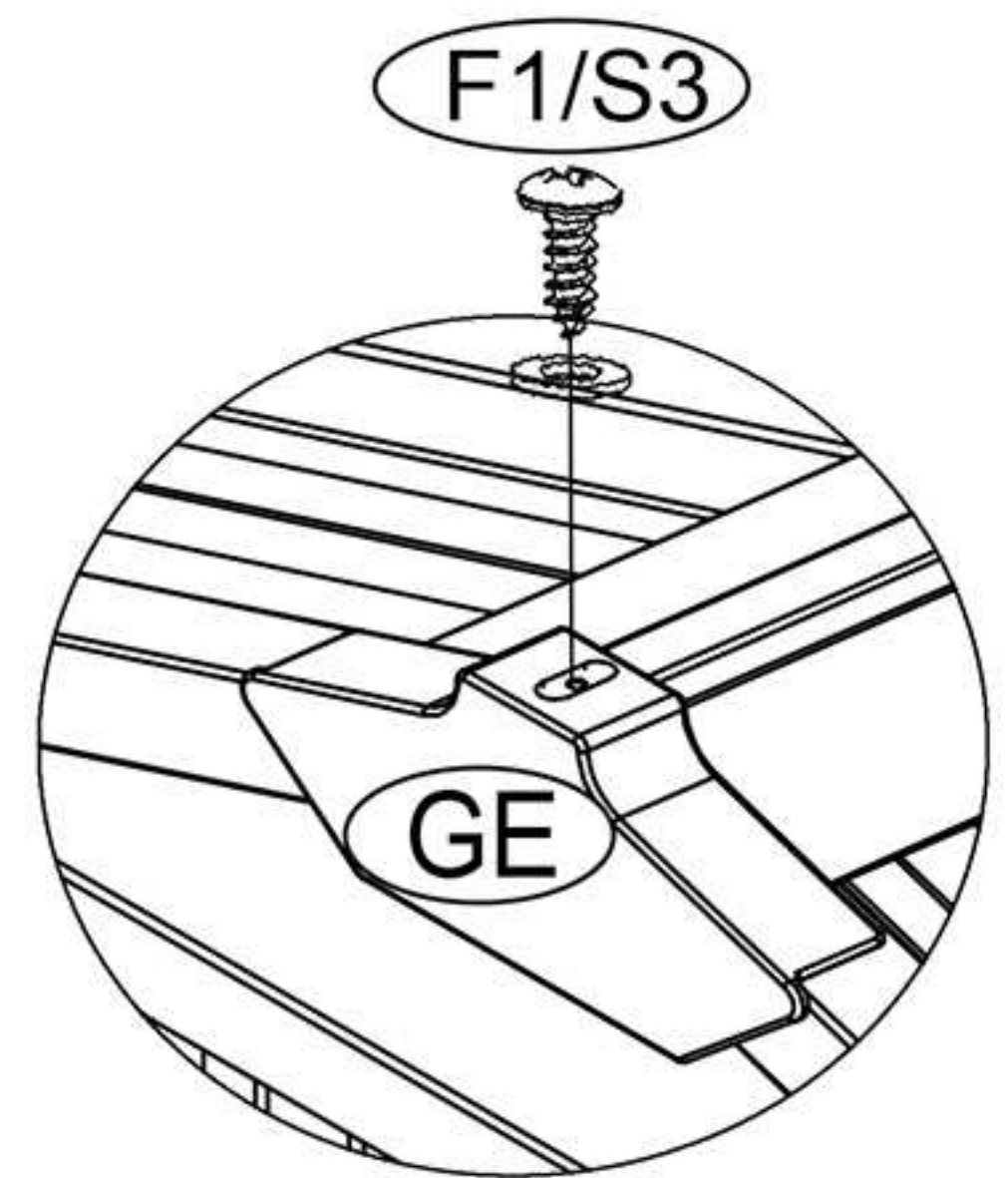
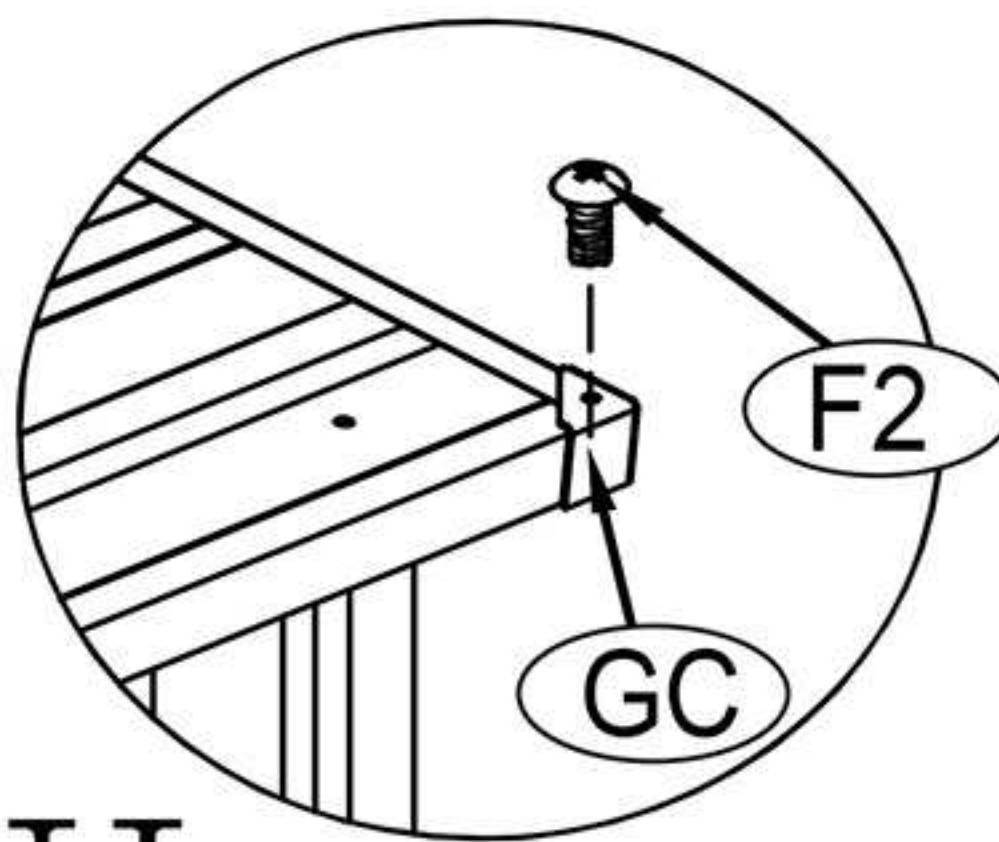
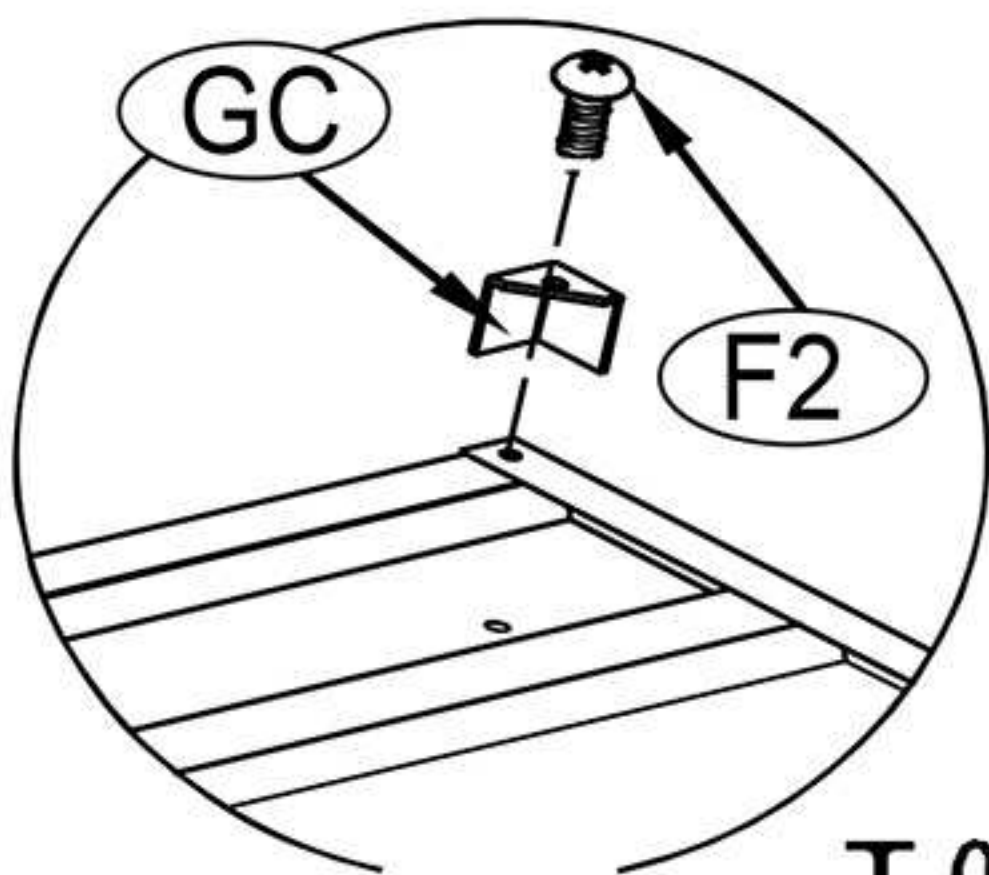
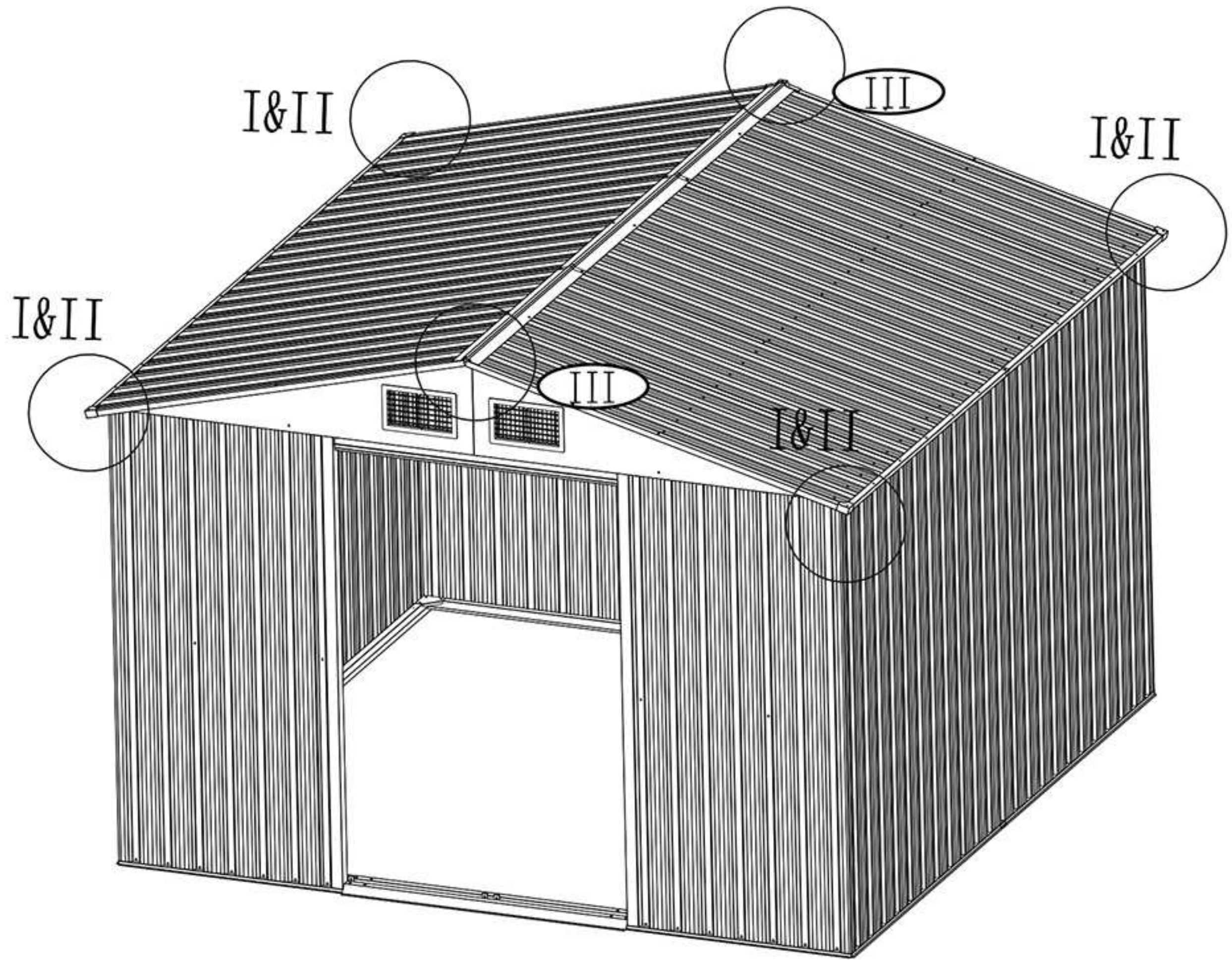

III



Lewa/Left

Prawa/Right

21

21

10

D1

D1

10

GB

GB

GD

10





GD

GD

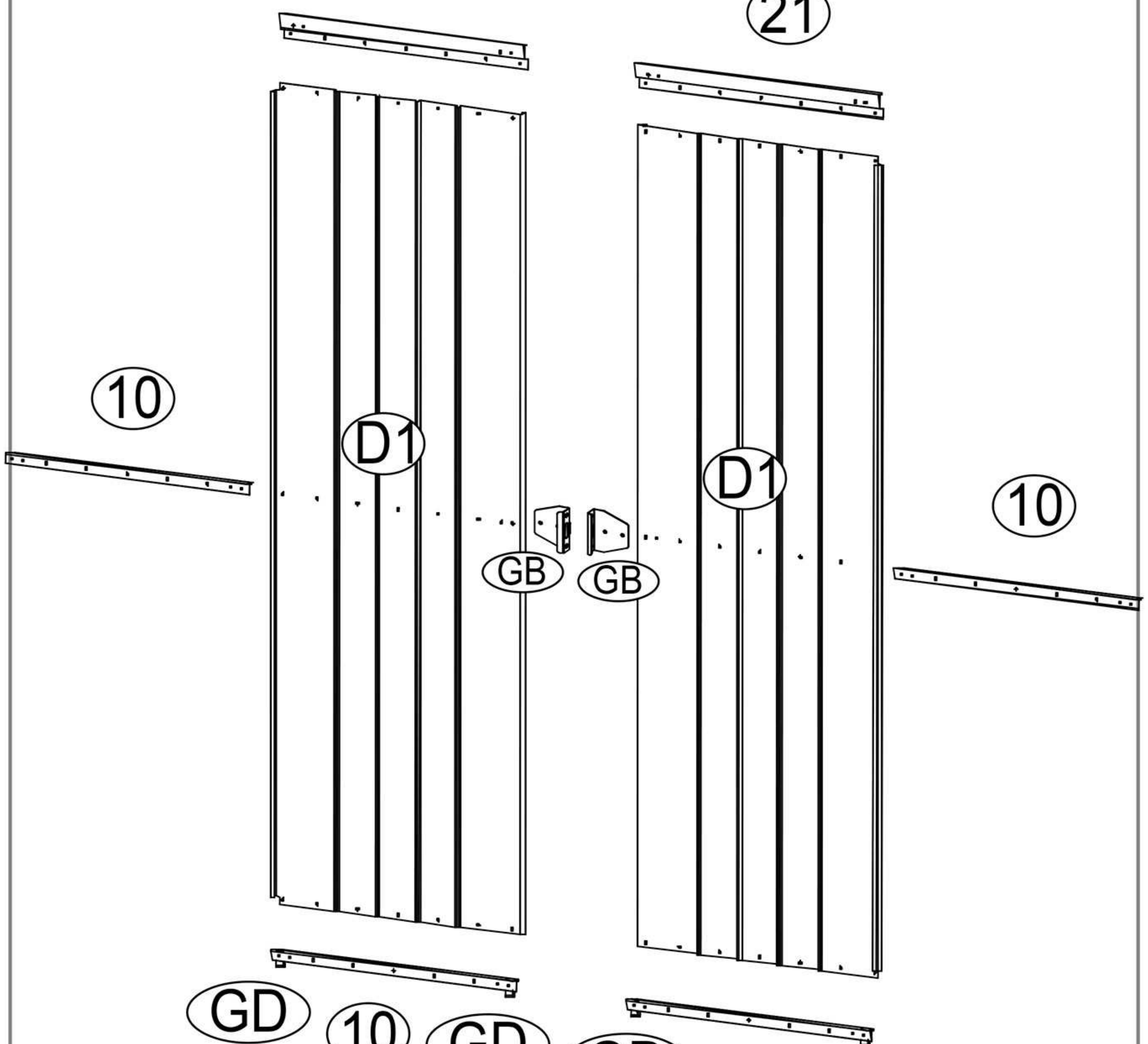
10

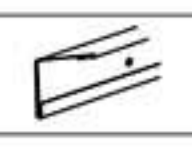
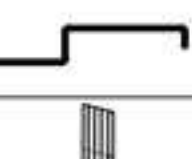
GD



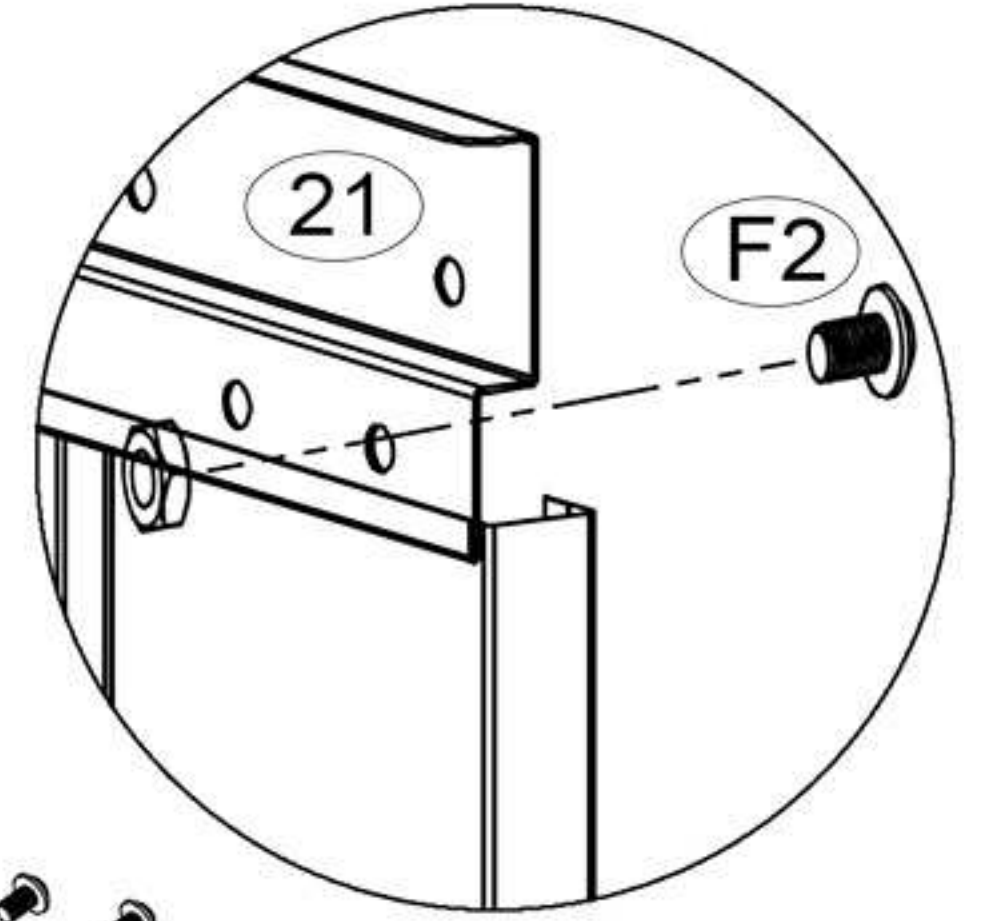
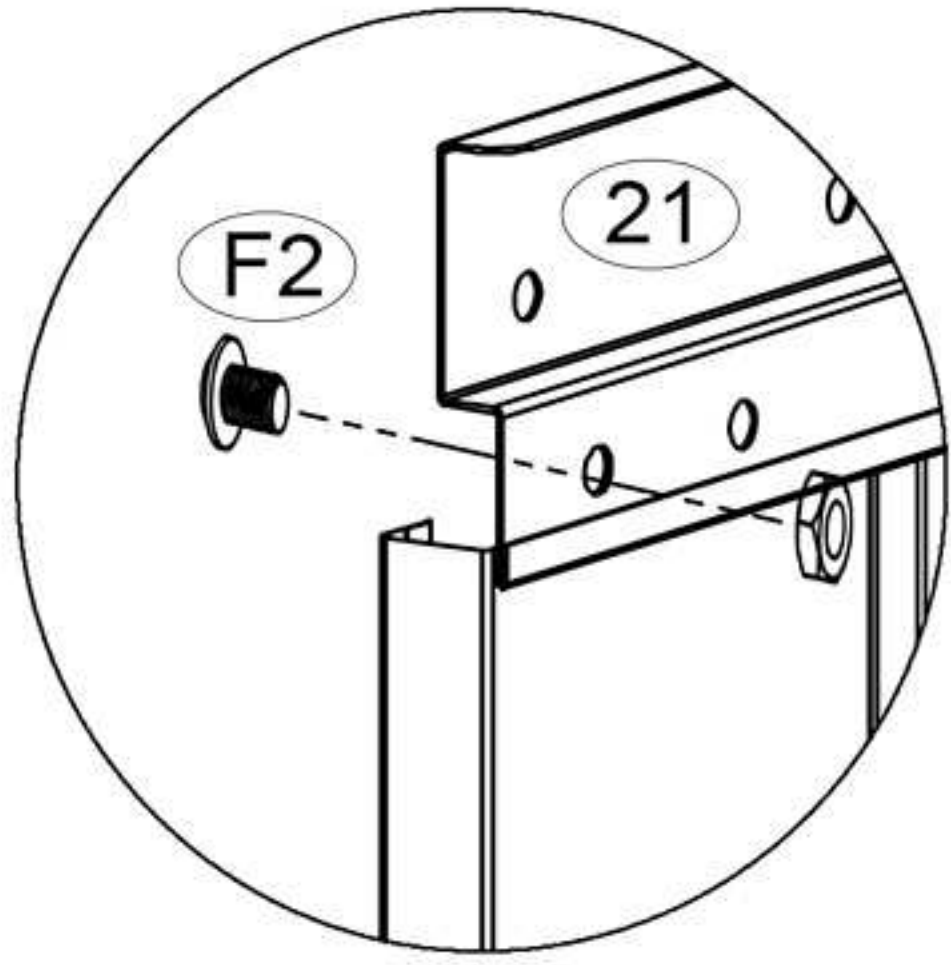

NO./NR.	PART/ELEMENT	QTY./ ILOŚĆ
10		4
21		2
D1		2
GD		4
F2		40

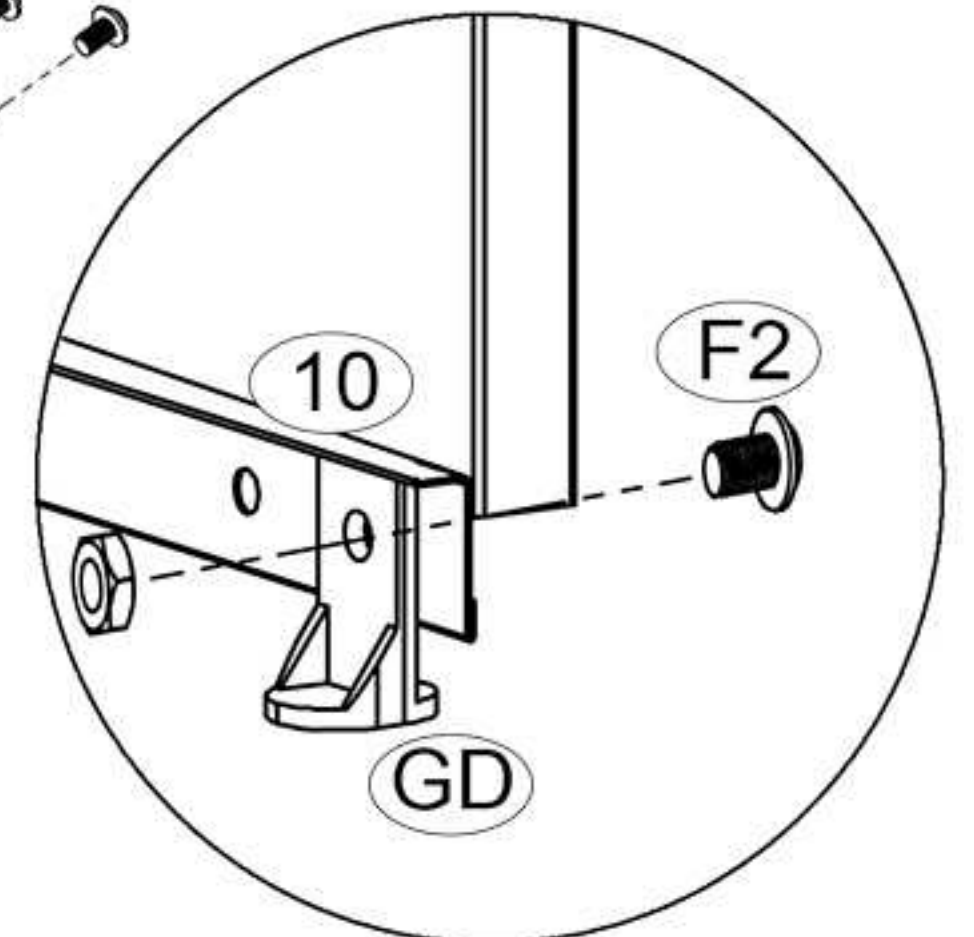
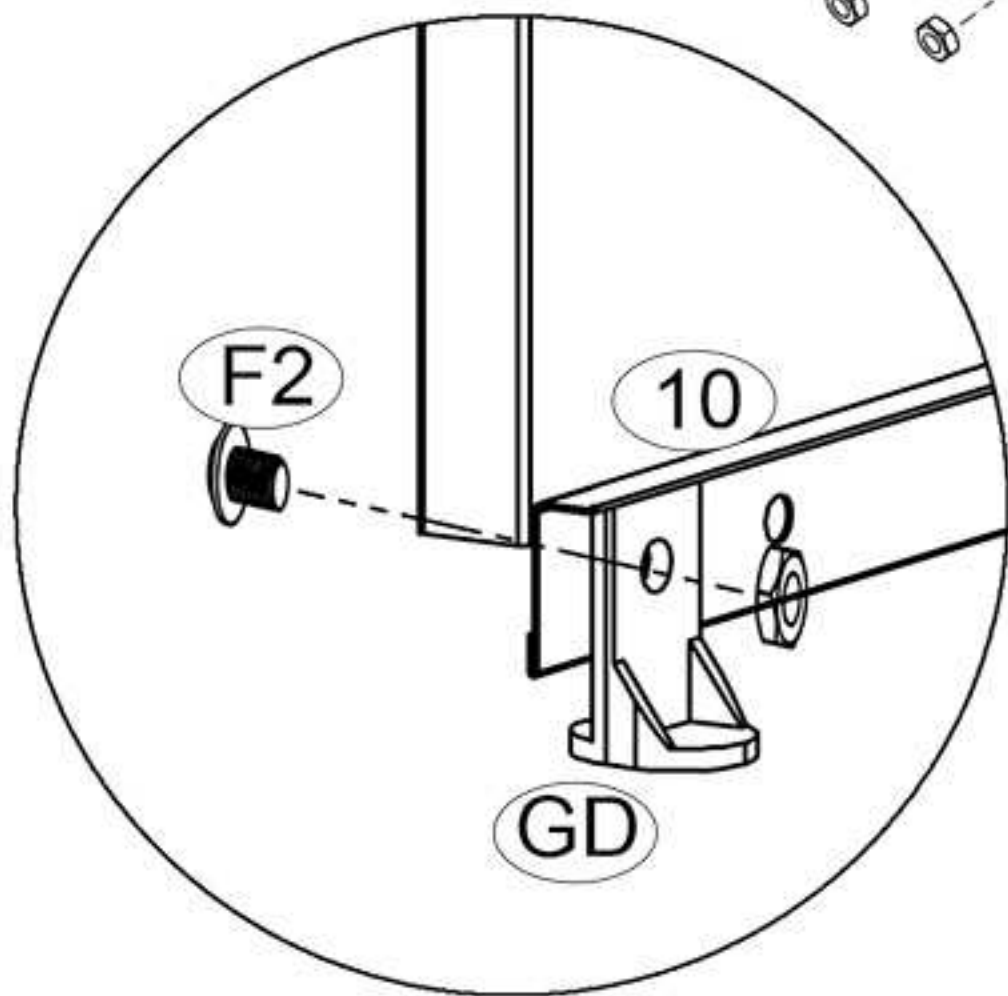
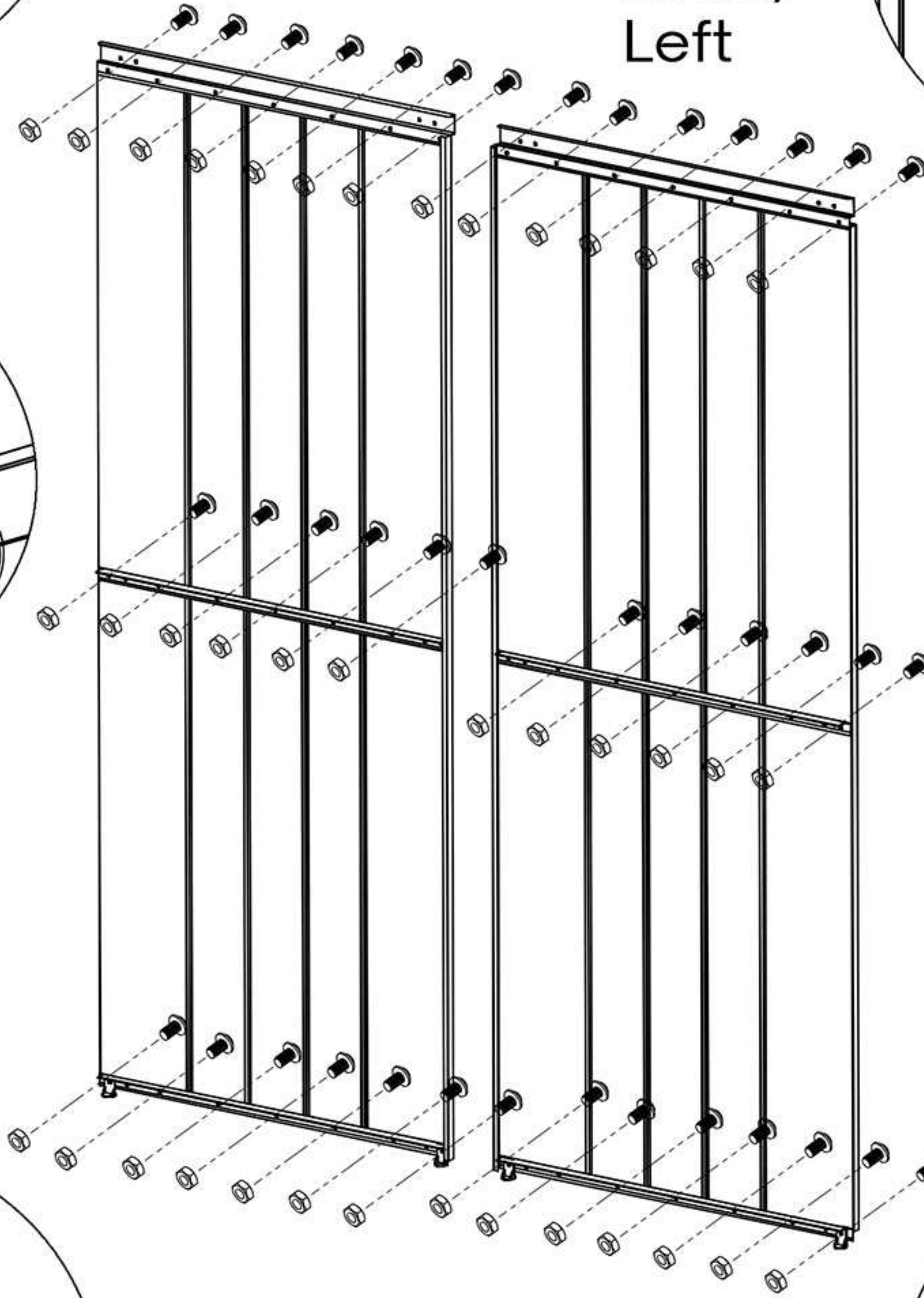
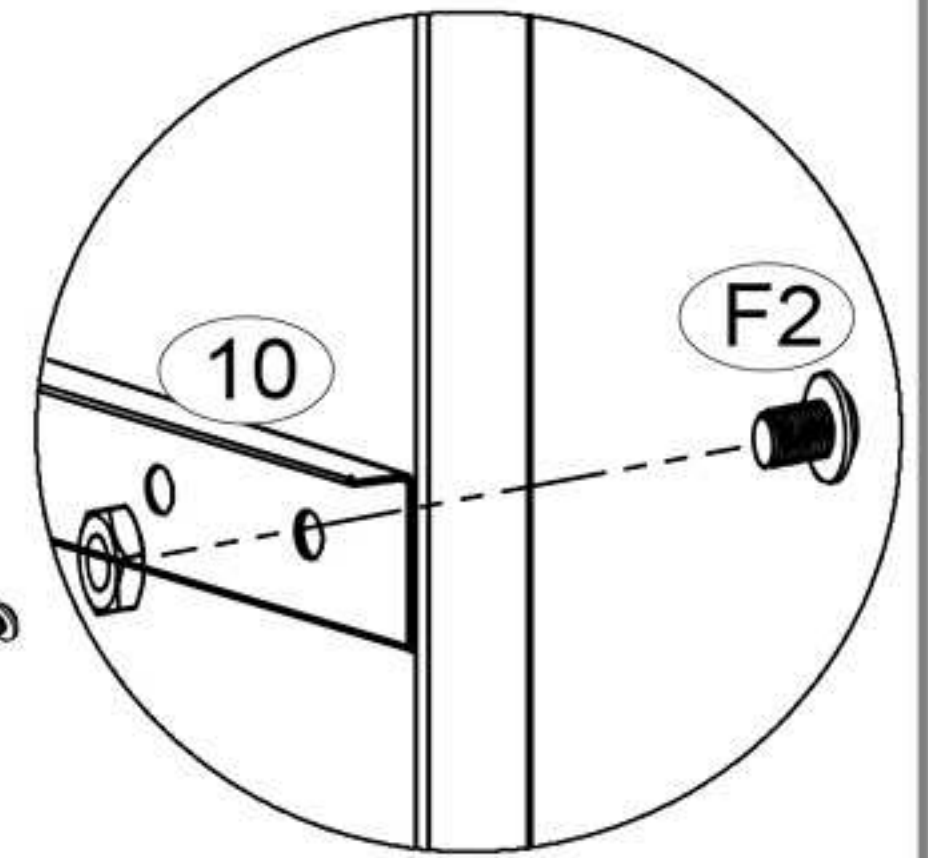
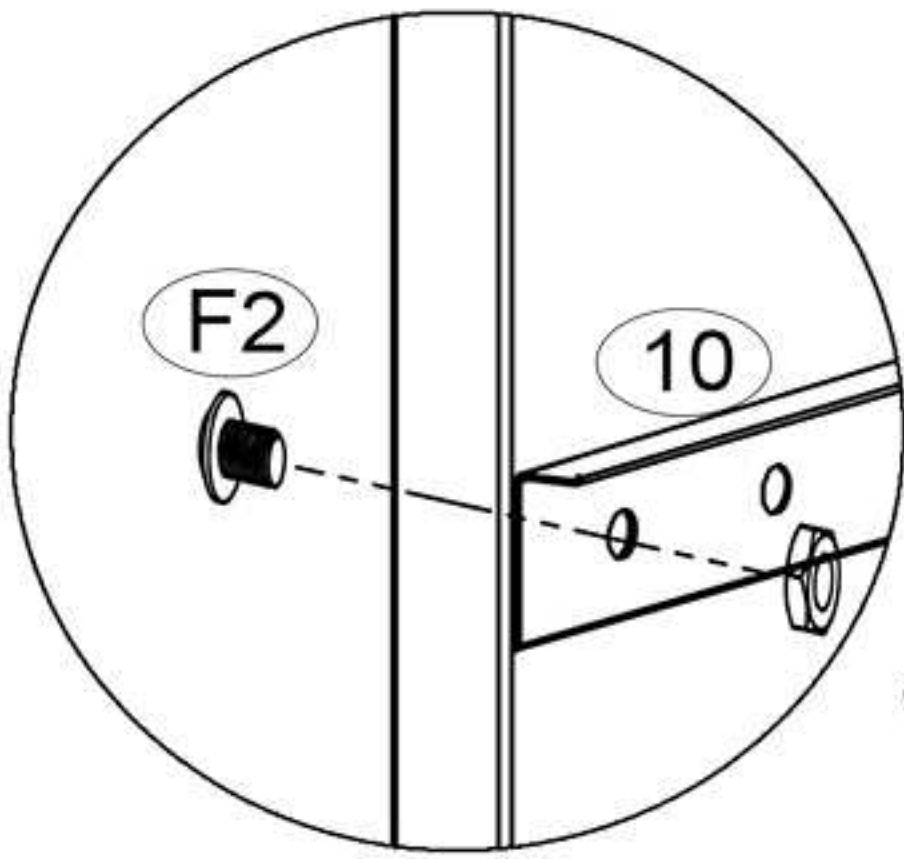

Prawa/  
Right

Lewa/  
Left

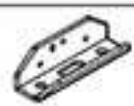

NO./NR	PART/ELEMENT	QTY./ ILOSC
F2		4
GB		2

# Lewa/Left Prawa/Right

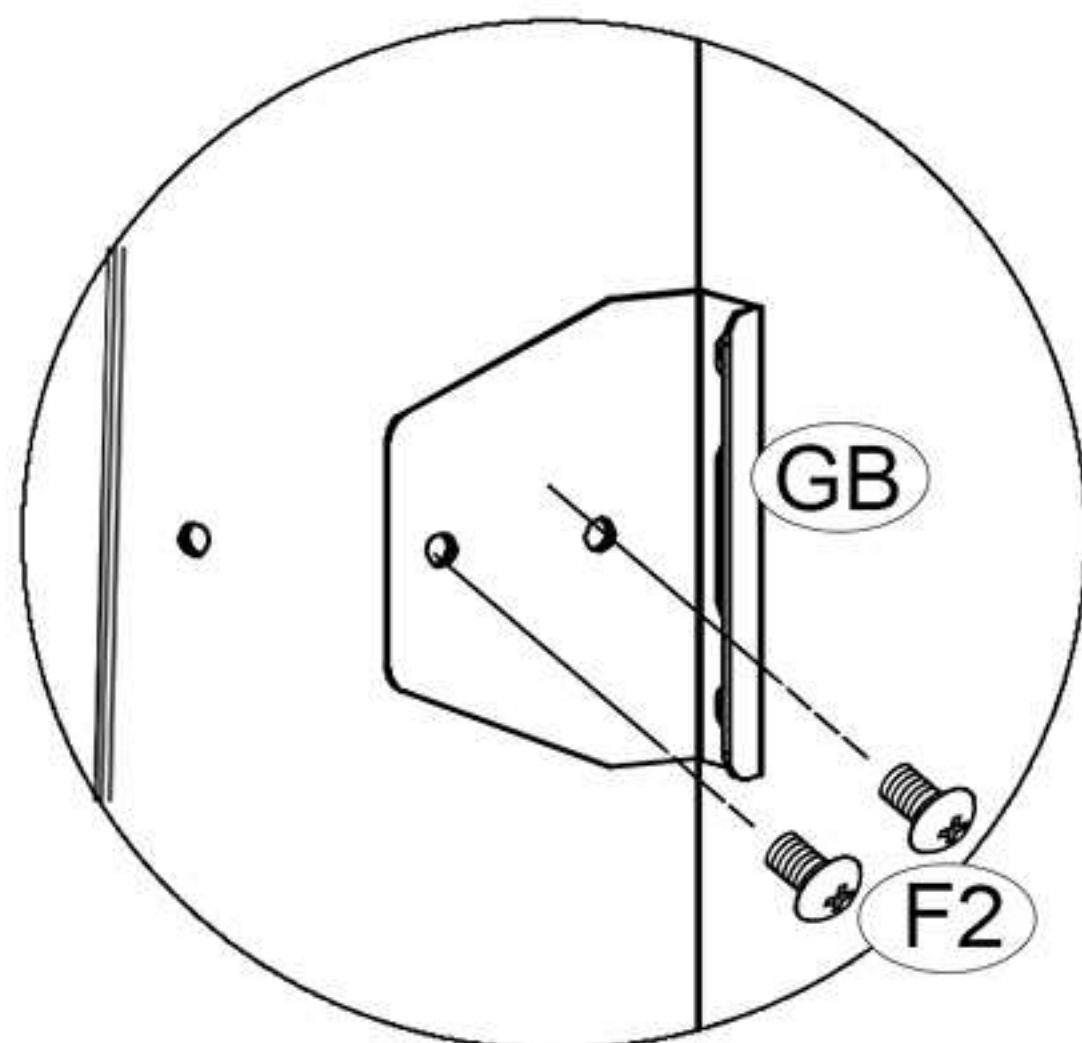
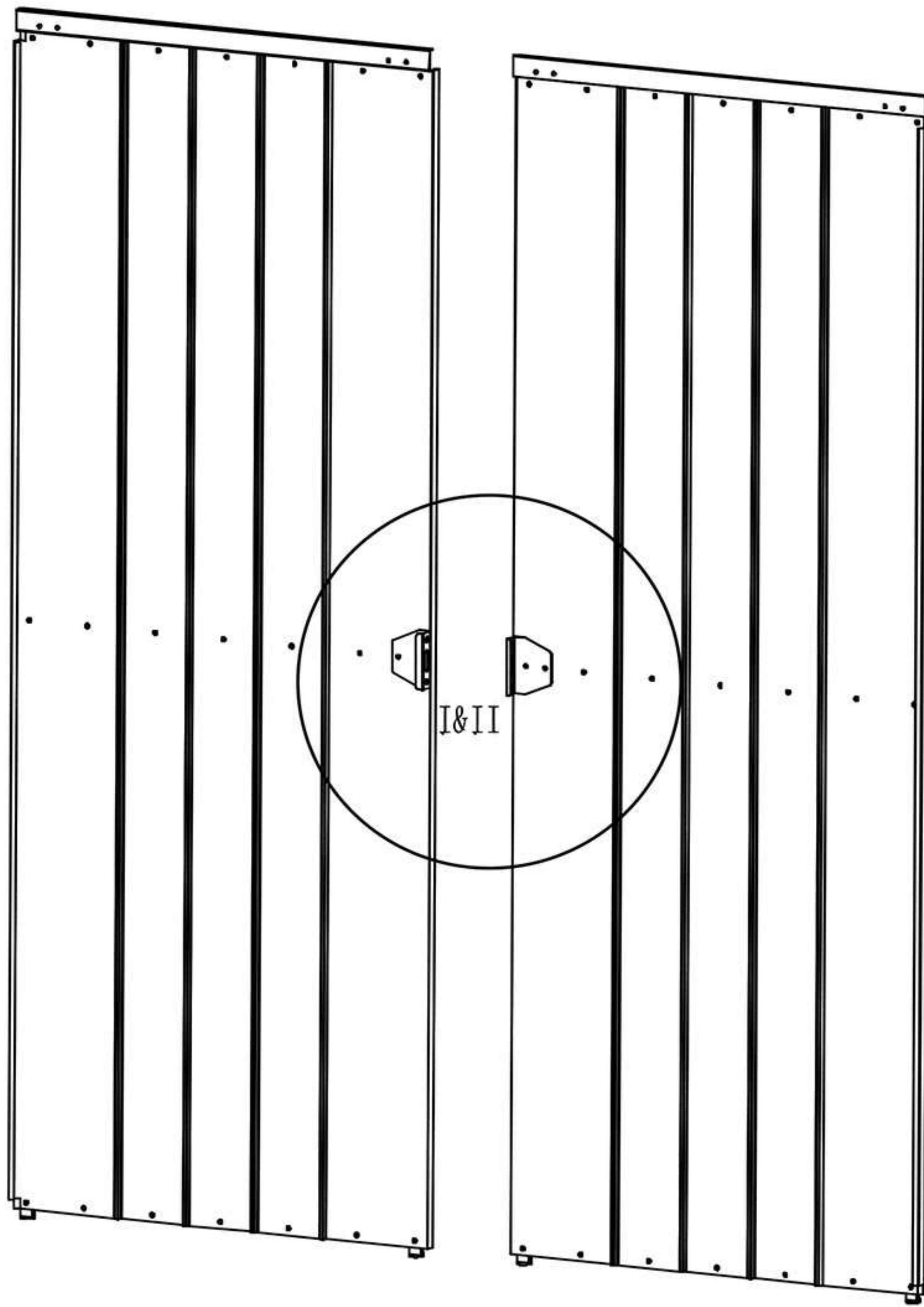

I&II

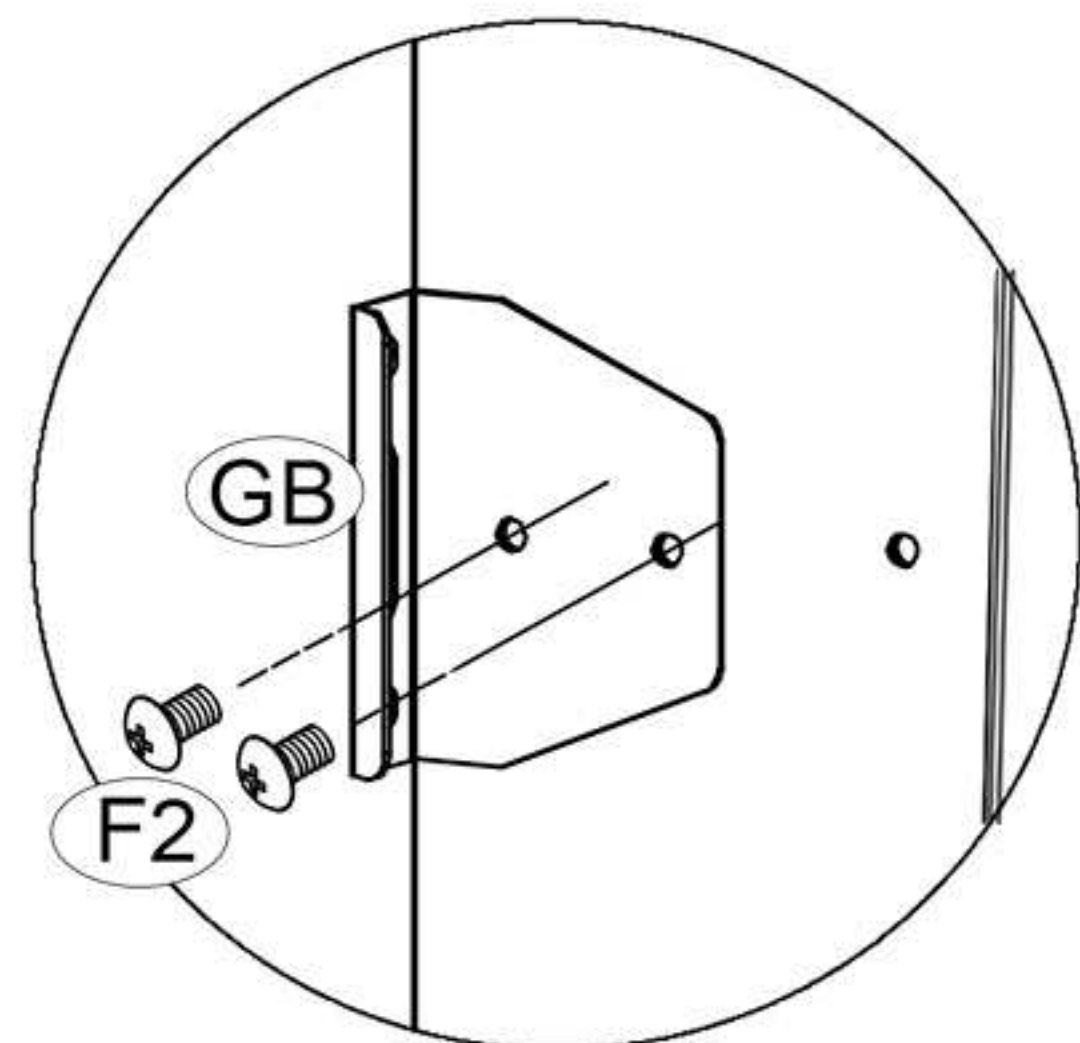

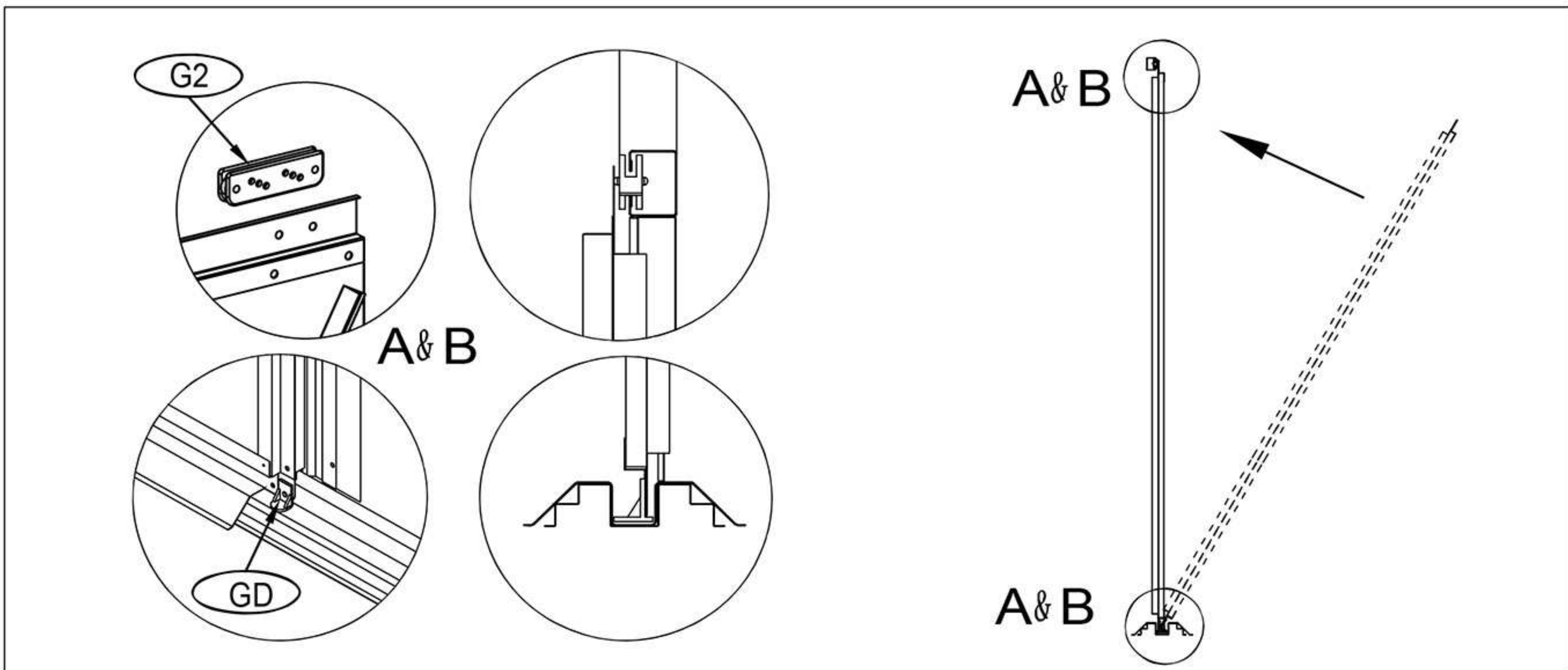
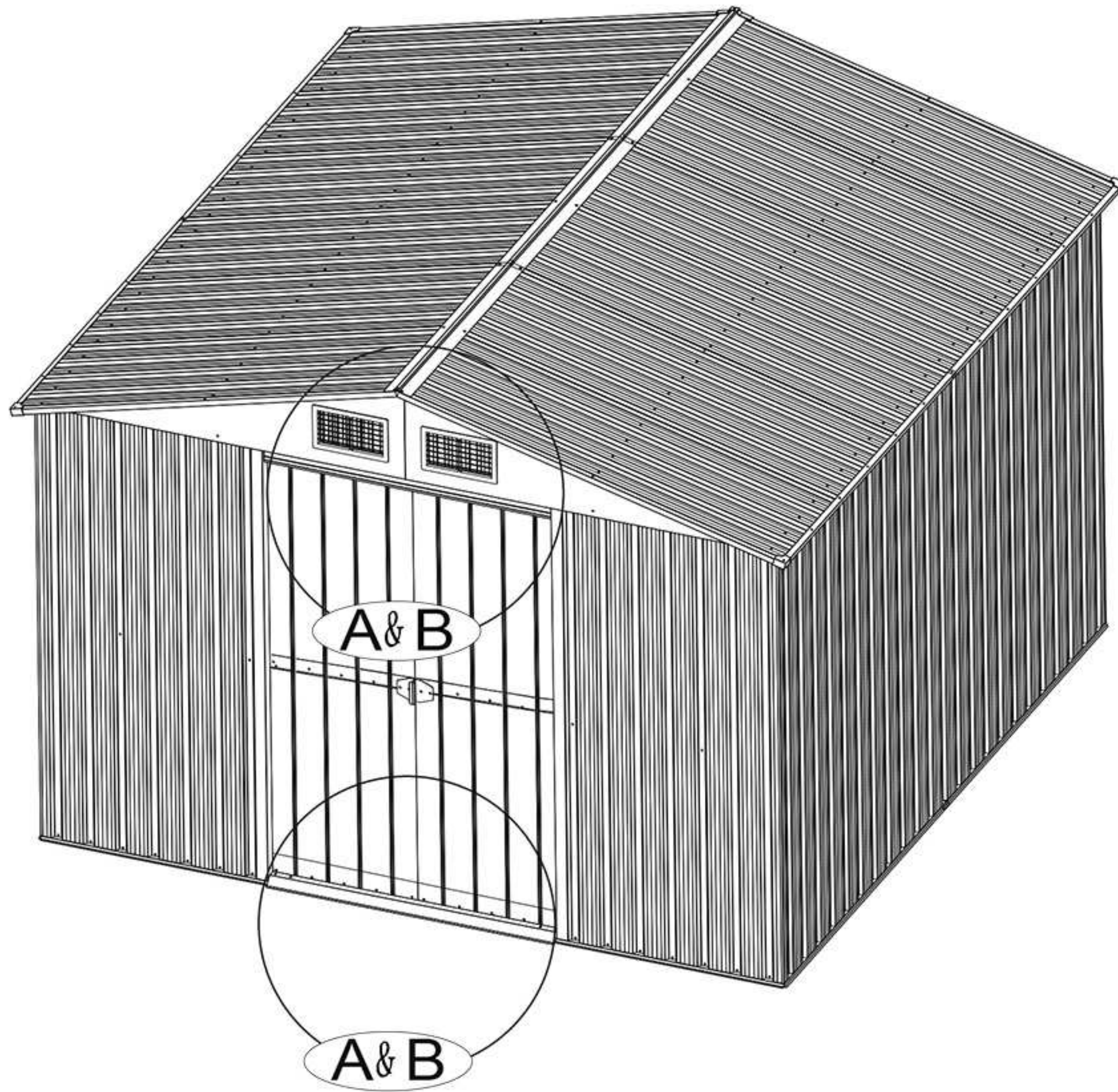

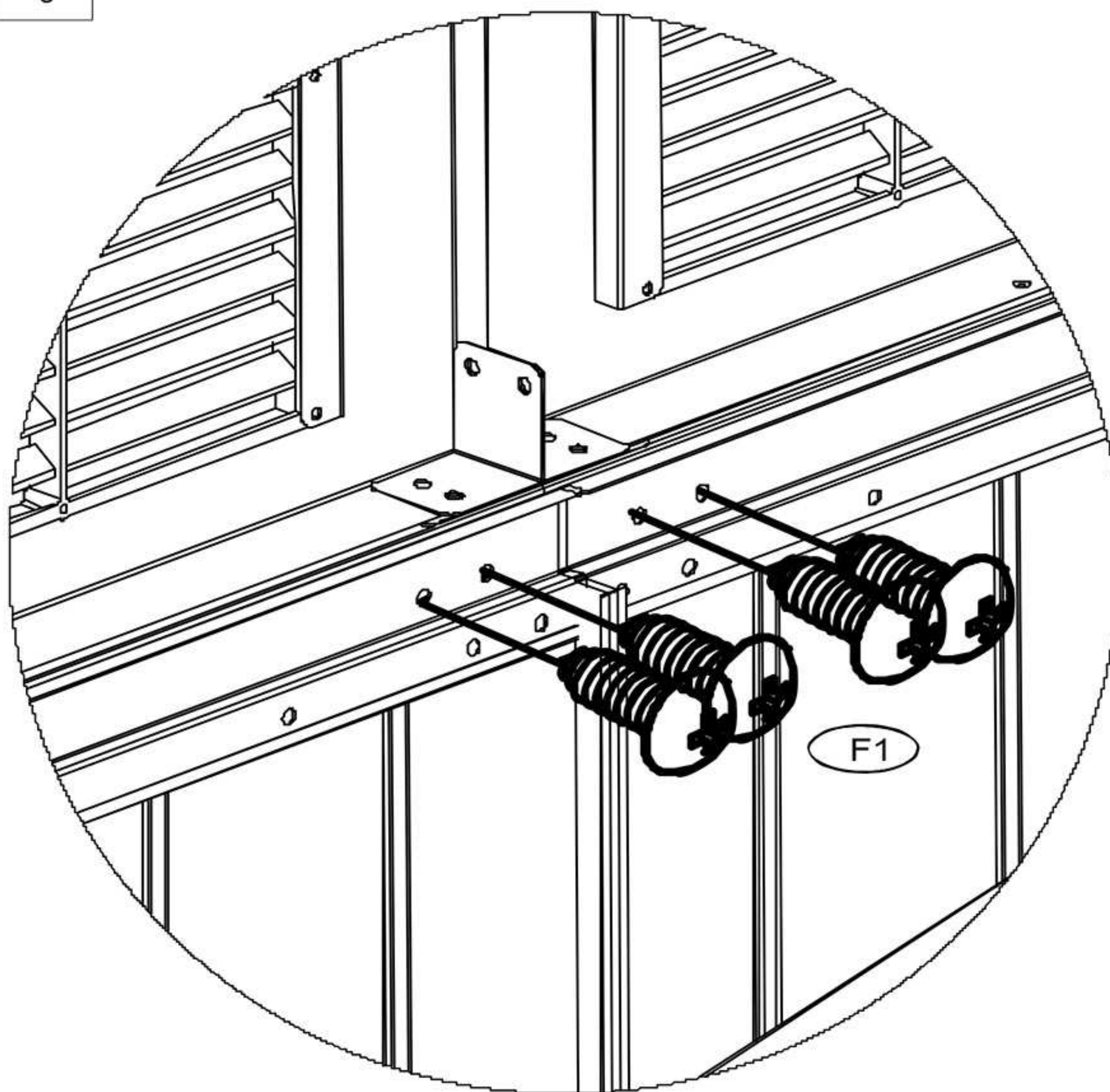

NO./NR	PART/ELEMENT	QTY./ ILOŚĆ
F1		8

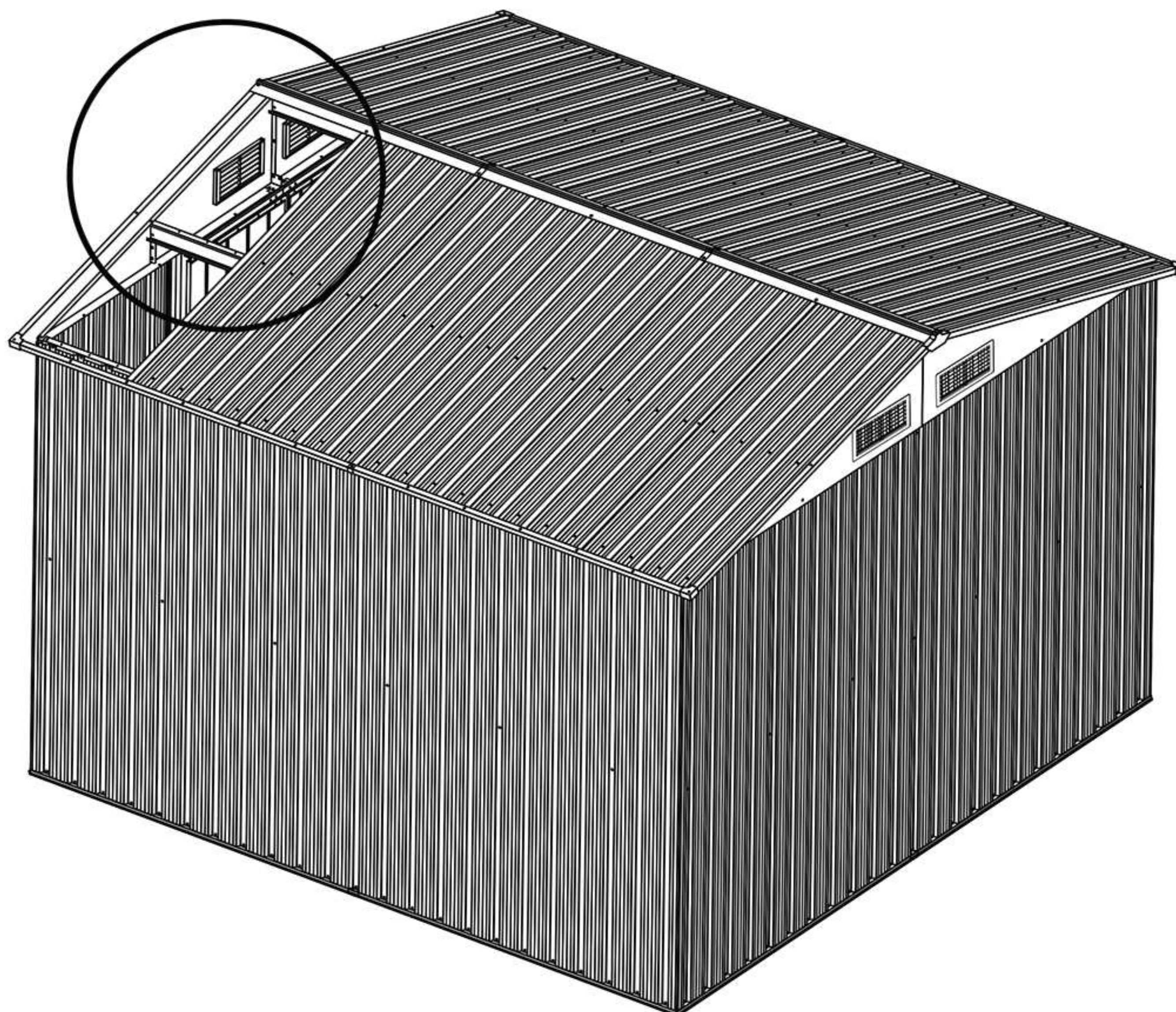

Zabezpieczyć drzwi przesuwne śrubą f 1 w pomieszczeniu narzędziowym  
Jednocześnie przymocuj szynę ślizgową g2il

Secure sliding door with f 1 screw in tool room Simultaneously fix the g2 slide rail



NO./NR	PART/ELEMENT	QTY./ ILOŚĆ
F1		3
11		1

